

KURUMSAL

1976 yılından beri otuz yıldır ulusal ve uluslararası motor sektörünün ihtiyaç duyduğu piston üretiminde rol oynamaktayız. 30 yıllık tecrübemiz, alanında uzman mühendis kadromuz, sürekli gelişim gösteren yapımız, güncel teknolojiyi kullanan makinelerimiz, ürün çeşitliliğimiz, üretim kapasitemiz ve satış sonrası desteğimiz ile motor sektörü için adeta piston görevi görmekteyiz. 2015 yılında, tecrübelerimize dayanarak aldığımız kararlarla radikal bir değişikliğe giderek motor endüstrisini ulusal ve global anlamda rahatlatacak üretim ve lojistik olanakları sağlamayı kendimize ilke edindik.

Üretim kapasitemizi artırmak için yaptığımız AR-GE çalışmaları neticesinde teknolojik altyapımızın tamamını yeniledik ve geliştirdik. Bu gelişmelerle birlikte hem sürekli üretim döngüsünü oluşturduk hem de ürünlerimizin kalitesini artırarak daha uzun ömürlü olmalarını sağladık. Kullandığımız robot teknolojiyiyle yaklaşık 300 farklı piston çeşidi için yıllık 300.000 adet üretim kapasitesine ulaştık.



Hizmet sağladığımız firmaların ve şirketlerin stok maliyetlerini düşürmek ve ihtiyaç anında taleplere hızlı cevap verebilmek için stok alanımızı genişlettik. Talep edilen ürünün ya da ürünlerin siparişini alt limit olmadan (tekli ve çoklu alım seçeneği) sadece yıllık değil, aylık veya haftalık zaman aralıklarıyla alarak da hizmet vermekteyiz.

MYM olarak, ulusal ve uluslararası motor endüstrisinin en küçük işletmesinden en büyük firmasına kadar üstün hizmet sağlamak için kurulduğumuzu bildirmekten onur duyuyoruz.

Misyonumuz

Köklü geçmişimize yakışır şekilde sürekli gelişim göstermek, üretim kapasitemizi artırmak, dağıtım ağıımızı genişletmek, ürettiğimiz ürünlerin dayanıklılık süresini uzatmak ve satış sonrası sağladığımız destekle benzersiz bir hizmet deneyimi yaşatmak.

Vizyonumuz

Türkiye’de ve dünyada rakip firmaların örnek olarak gösterdiği ve ilham aldığı, sadece ürettiğimiz kaliteli ürünlerle değil aynı zamanda sağladığımız hizmetle de fark yaratan bir şirket olmak.

Stratejimiz

AR-GE çalışmalarımızla piston üretimindeki modernleşmeyi sağlamak ve üretim sonrası hizmetlerimizle ulusal ve uluslararası motor sektörüne yeni bir yön vermek.



ÜRETİM

Tekirdağ Çerkezköy de bulunan; biri 5000 m² açık 4000 m² kapalı, diğeri 10000 m² açık 7000 m² kapalı alanda bulunan fabrikalarımızda, toplam 58 personelle üretim faaliyetlerine devam edilmektedir. Üretim prosesleri son teknoloji ürünü tezgah ve aparatlarla gerçekleştirilmekte, sonrasında ürünler hassas kontrol cihazlarında denetlenerek, ürün pazara ulaştırılmaktadır.sağlamayı kendimize ilke edindik.

PİSTON VE SEGMAN MONTAJ TALİMATI

Segmanlar pistonların üzerinde montajlı olarak siz müşterilerimize teslim edilmektedir. Buna rağmen pistonlar motora takılmadan önce aşağıdaki hususlar uygulanmalıdır:

- Segmanların kanala doğru oturup oturmadığı kontrol edilmelidir.
- Segman kanallarının temiz olup olmadığı kontrol edilmelidir.
- Segmanlarda bulunan üstü gösteren yazının pistonun üst kısmına bakacak şekilde takılı olması sağlanmalıdır.
- Segmanların pistondan sökülüp tekrar takılması gereken durumlarda en alttaki segmandan başlayarak uygun bir segman pensesi ile takılmalıdır. Bu montaj sırasında segman gereğinden fazla açılmamalı ve maksimum 1 dakika açık tutulmalıdır. Aksi takdirde segman deforme olup fonksiyonunu yerine getiremeyebilir. Segmanlar radyal yön haricinde, dikey olarak esnetilmemelidir.
- Yağ segmanlarında spiral yayın birleşim yeri ile segman ağızı zıt yönde olacak şekilde (180°) kaçık olmalıdır
- 3 parça yağ segmanlarında önce yay daha sonra lameller yayı kilitleyecek şekilde takılır. Montaj sırasında yay ve lamel ağız açıklıkları kaçık konumlandırılmalı, bu açıklıkların üst üste gelmeleri engellenmelidir.
- Segman montajı tamamlandıktan sonra segmanların ağızları piston çevresinde eşit bir şekilde dağıtılmalıdır (Örn.: 3 segmanlı pistonlarda 120° lik açılarla).

Segman montajı tamamlanmış pistonun motora montajı sırasında aşağıdaki maddeler dikkate alınmalıdır:

- Pistonlarda bulunan yanma hücresi, pim deliği gibi unsurlar merkezde olmayabilir. Pistonun doğru çalışabilmesi için pistonun üst kısmında bulunan, takma yönünü gösteren işarete göre montaj yapılmalıdır.
- Kaplamalı ve anotlamalı yüzeylerde hiçbir işlem yapılmamalıdır.
- Grafit kaplamalı pistonlarda, grafit yüzeyinden ölçü almayınız. Bunun yerine ölçüler burada bulunan pencereler üzerinden alınmalıdır..
- PisPiston tepesinde bulunan Çap + Sp değeri silindir çapına eşit olmalıdır. Aksi halde montaj gerçekleştirilmemelidir.
- Pistonun motora takılması sırasında doğru aletler kullanılmalıdır.
- Sökülen eski piston ve segmanlar uygun bir şekilde bertaraf edilmelidir.



PİSTON ÜZERİNDEKİ BİLGİLER

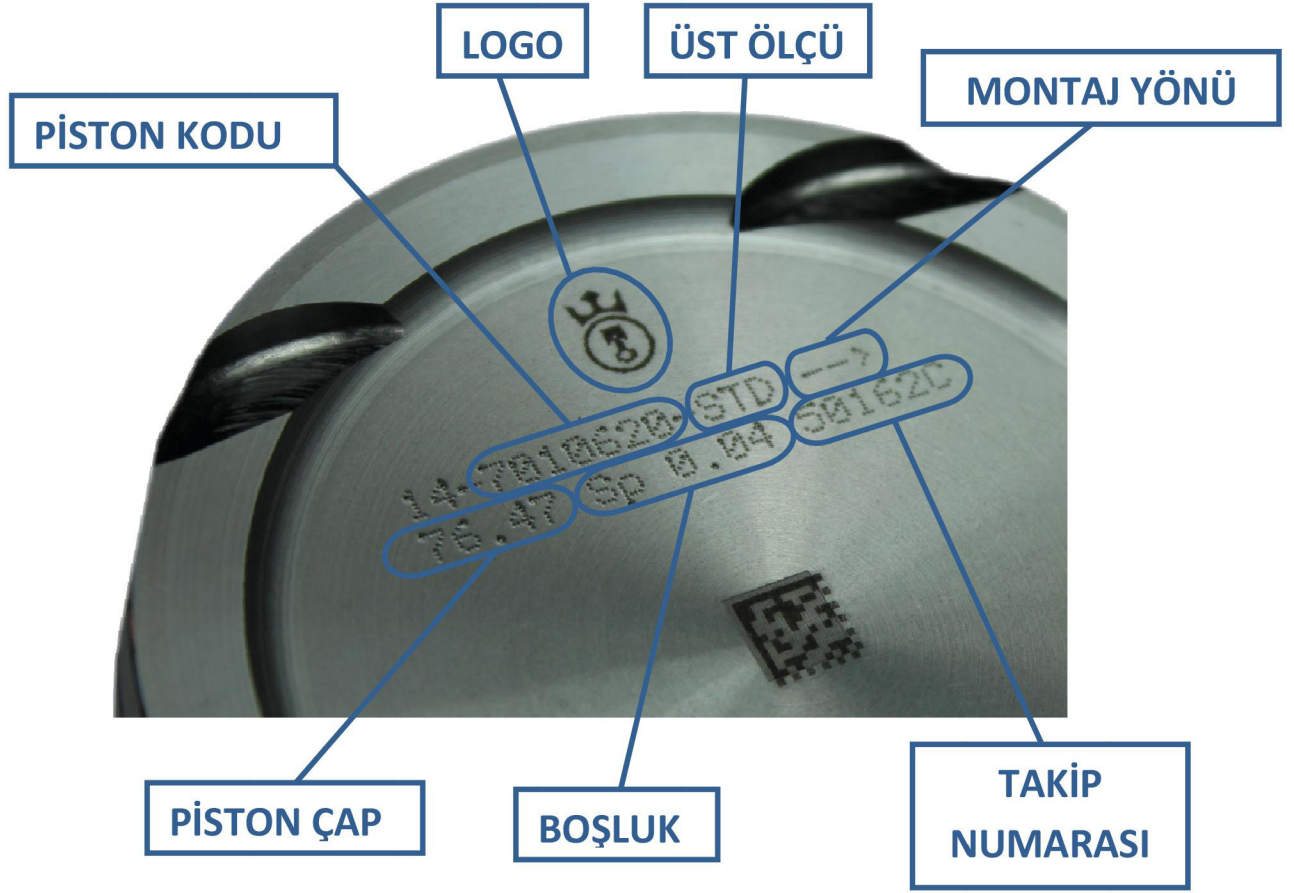

PİSTON ÖLÇÜLERİ

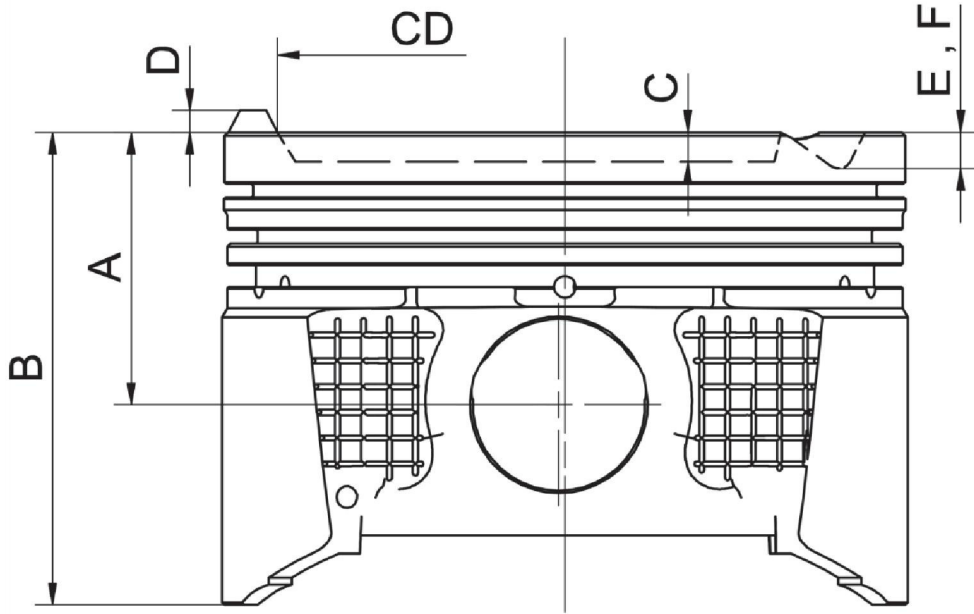

- A - Kompresyon Yüksekliği
- B - Toplam Boy
- C - Yanma Hücre Derinliği
- D - Tepe Fazlalık Yüksekliği
- CD - Yanma Hücresi Çapı
- E,F - Subap Yuva Derinliği

Piston Özellikleri

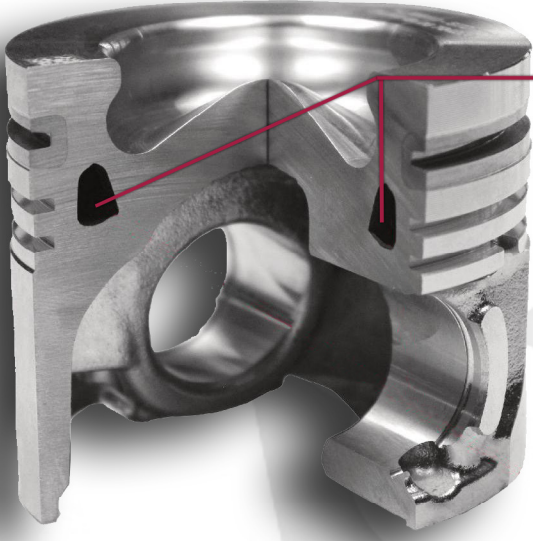

Yağ Galerisi

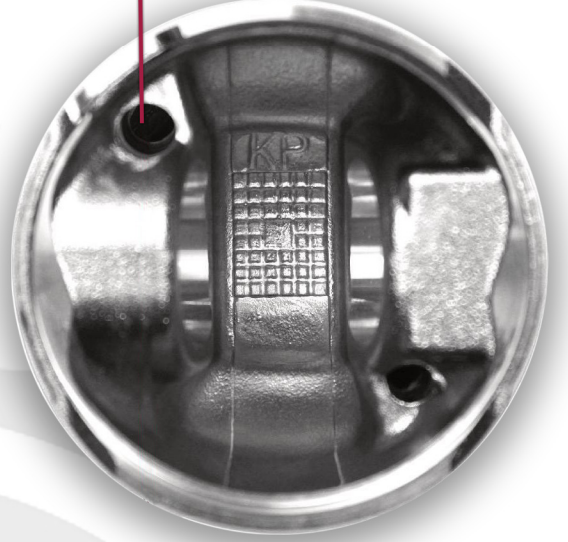

Sert Anotlama

Burç

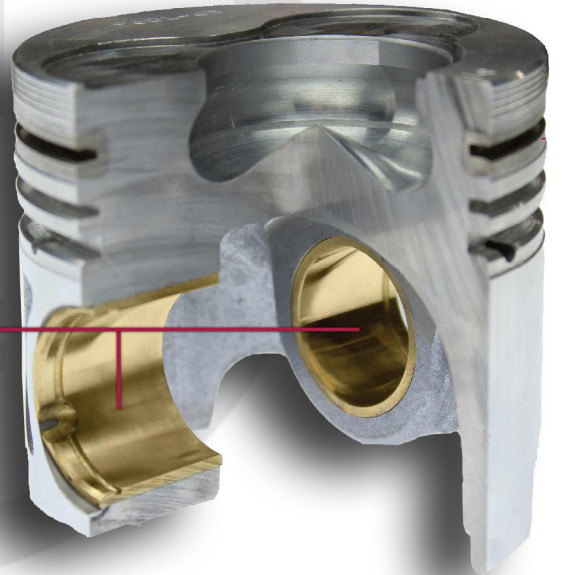

Saç Plaka

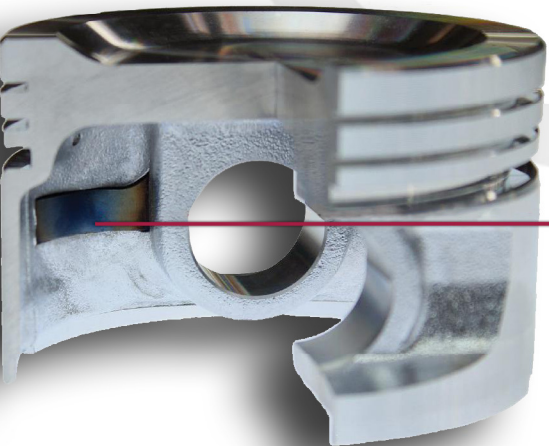

1) Segman Özellikleri

Tepe Segmanları		
500	Dikdörtgen segman	
503	Yarı trapez segman	
504	Trapez segman (15°)	
505	Trapez segman (6°)	
514	Trapez segman (10°)	

Sıyırıcı Segman		
501	Konik segman	
502	Konik-Pahlı segman	
506	Sıyırıcı segman	
507	Sıyırıcı-Pahlı segman	
508	Burun sıyırıcı segman	
509	Burun sıyırıcı-pahlı segman	
510	Pahlı-yarı trapez segman	
511	Pahlı-trapez segman	

Yağ Segmanı		
600	Yarıklı yağ segmanı	
601	Pahlı yağ segmanı	
602	Çift pahlı yağ segmanı	
603	Spiral yaylı yağ segmanı	
604	Spiral yaylı pahlı yağ segmanı	
605	Spiral yaylı çift pahlı yağ segmanı	
606	Spiral yaylı iç pahlı yağ segmanı	
700	RIK-VENT açıcılı yağ segmanı	

2) Kenar ve Yüzey Özellikleri

IF	Üst iç kenar pahlı	
IFU	Alt iç kenar pahlı	
IW	Üst iç kademesi	
IWU	Alt iç kademesi	
B	Fıçı yüzey	
N	Gömme yüzey kaplaması	

3) Malzeme ve Kaplama Özellikleri

Cr	Yüzey krom kaplamalı
Cr3	Yan yüzey krom kaplamalı
Cr4	Full krom kaplamalı
Mo	Yüzey molibden kaplamalı
Nit	Nitrid kaplamalı
PI	Sprey plazma kaplamalı

QBCr	"Quick Break-In" krom kaplama
IP	İon kaplamalı
Fe	Ferrox işlemeli
P	Fosfat kaplamalı
S	Çelik segman

COMPANY

We have a role in national and global engine industry whom needs pistons, for 30 years since 1976. We have been producing pistons for domestic and international markets years since 1976. We play a major player role in engine industry with our 30 years of experience, expert team of engineers, developing company structure, up to date machinery, product variety, production capacity, after sales services. We made a radical change and assumed the principle of providing production and logistic facilities for engine industry in 2015.

We developed and renewed our technological infrastructure as the results of our R&D efforts to increase our capacity. With these progresses we increased our quality of our products and made them more long lasting. We reached 300.000 product capacity per year with our 300 sort of pistons with the robot technology we use.

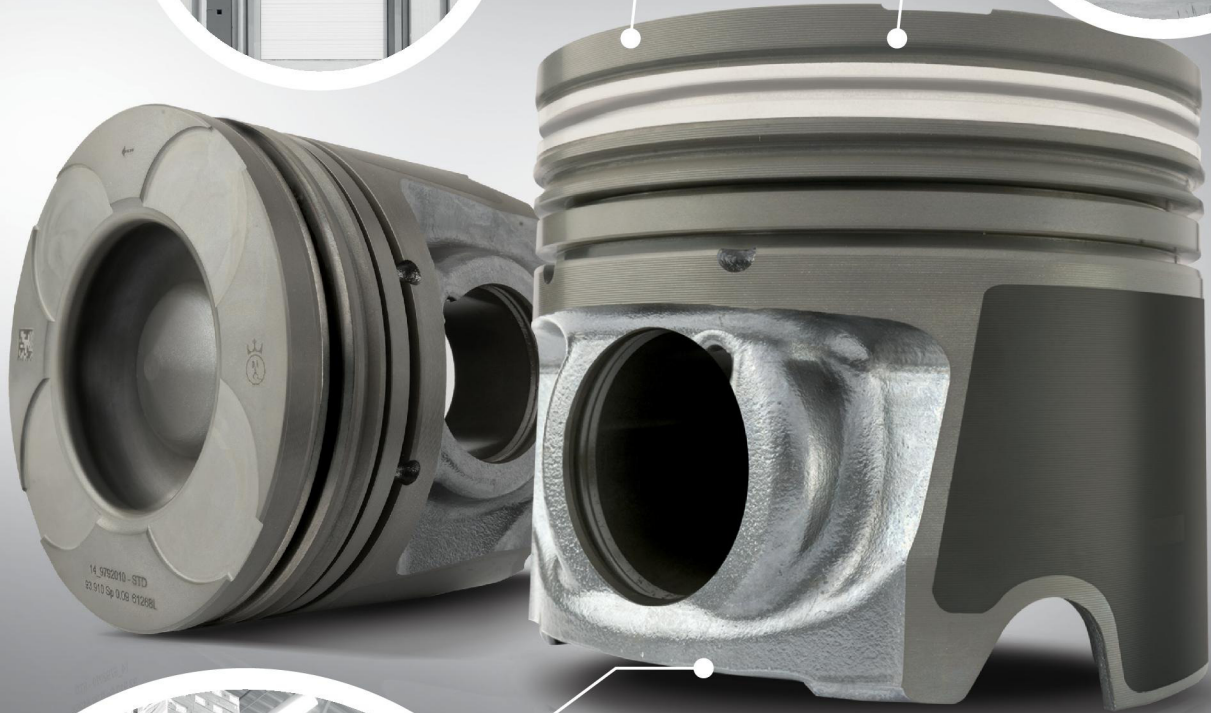

We had enlarged our inventory space to reduce the inventory costs and answers the demands when its needed fort he companies we serve. Without any limits we provide the demands not just by periods of years, we also serve the companies by periods of months and weeks.

As MYM we are proud to announce that we are established to provide superior service for the smallest business to the largest firms of national and global engine industry.

Our mission

To show a steady improvement to our well-established past, to increase our production capacity, to extend our distribution network, to extend the durability period of our products and to provide a unique service experience with the support we provide after sales.

Our vision

And that in Turkey as an example of competing firms in the world and was inspired, not only with quality products that we produce at the same time also be a company that makes a difference in the service we provide.

Our strategy

To provide modernization of piston production with our AR-GE work and give a new direction to the national and international motor sector with our after-production services.



MANUFACTURING

We do our manufacturing activities with our 58 employees, in our factories with one of them are 5000 m² outdoor and 4000 m² indoor and the other one is 10000 m² outdoor and 7000 m² indoor at Cerkezkoý, Tekirdag. We present our products to the market by controlling the quality with our post production devices, and using the latest technology.

RECOMMENDATIONS FOR THE INSTALLATION OF RING AND PISTON

We serve the pistons with pre-assembled piston rings to our customers.
Even so we recommend to check following points:

- Please check if the piston rings fit in their grooves.
- The ring grooves must be clean.
- The top marking on the rings must be upwards to piston crown.
- In case the piston rings have been disassembled, please assemble the rings starting from the lowest ring upwards using appropriate tool. Do not open the rings more than necessary and do not strain the rings more than 1 minute, since it could cause deformation of the ring.
- For oil rings with spring; spring ends must be positioned 180° from ring gap.
- For oil rings 3 pieces type; spring should be assembled first. After the spring has been installed the rails must be mounted holding the spring. The spring ends must be held together to avoid overlapping.
- After assembling the rings, ring gaps are to be positioned with same angle to each other around the piston (Example: On a piston with 3 rings, ring gaps must be positioned 120° to each other).

For a correct installation of the piston into engine, please read following points carefully:

- Some features on a piston like chamber, valve reliefs, pin hole etc. can be asymmetric or eccentric from piston center. For a proper functionality, direction mark on top of the piston must be considered.
- Do not machine any coated and anodized surface.
- Do not measure any dimension on graphite coated surfaces. Uncoated areas are recommended for measurements.
- Diameter value + Sp-Value must be equal to liner diameter. If it is not the case, installation must be cancelled.
- Appropriate tools must be used for installing pistons into engine.
- Removed old parts must be disposed accordingly.



INFORMATION MARKS ON PISTON





PISTON DIMENSIONS

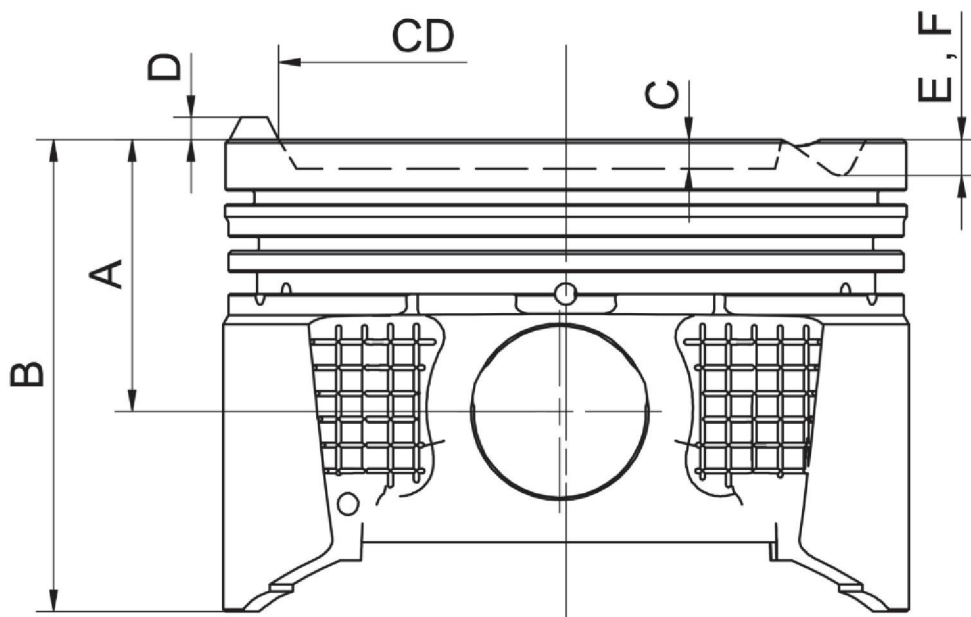

- A - Compression Height
- B - Total Length
- C - Chamber Depth
- D - Dome Height
- CD - Chamber Diameter
- E,F - Valve Cutouts Depth

Piston Specifications

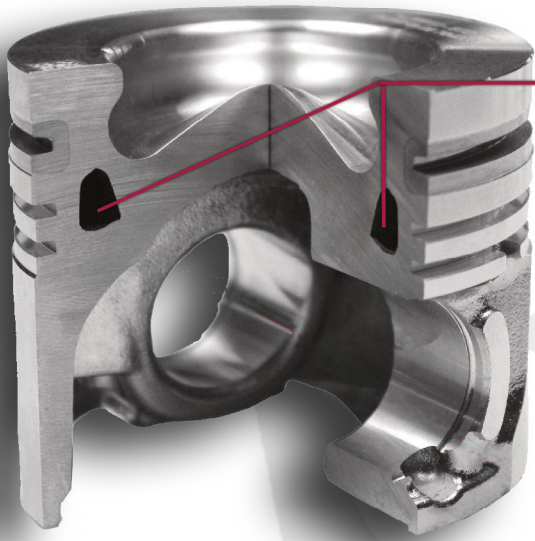

Oil Gallery

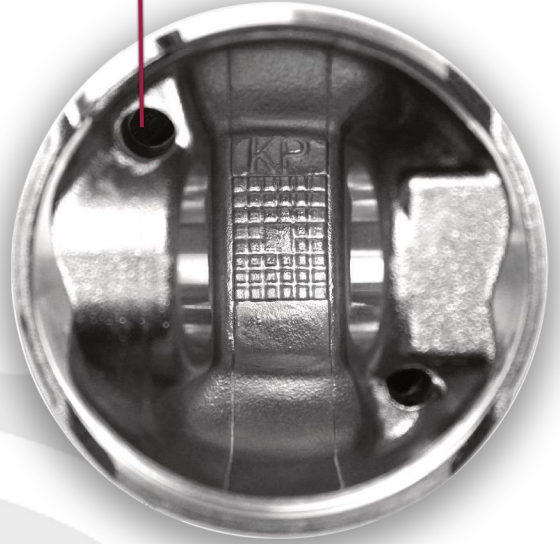

Hard Anodising



Bushing





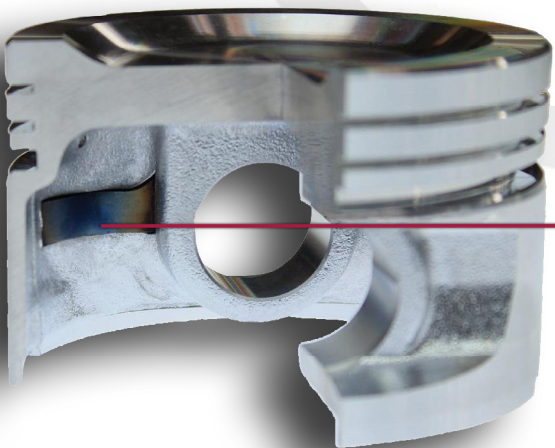

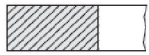
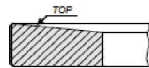
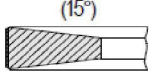
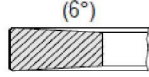
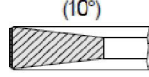

Steel Plate

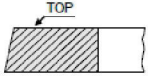
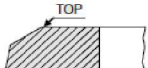
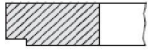
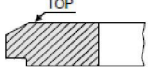
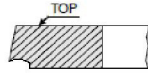
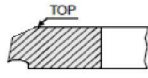
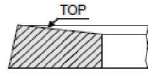
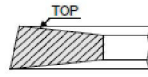

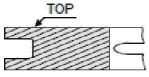
1) Cross-section configurations

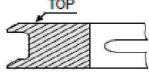
Top Rings		
500	Rectangular ring	
503	Half Keystone ring	
504	Keystone Ring (15°)	
505	Keystone Ring (6°)	
514	Keystone Ring (10°)	

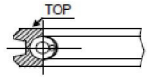
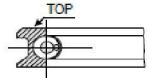
Compression Rings		
501	Taper-faced ring	
502	Taper-faced bevelled ring	
506	Scraper ring	
507	Scraper bevelled ring	
508	Taper-faced Napier ring	
509	Taper-faced Napier bevelled ring	
510	Taper-faced, Half Keystone ring	
511	Taper-faced, Keystone ring	

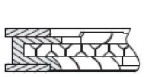
Oil Rings		
600	Slotted Oil control ring	
601	Bevelled-edge Oil control ring	
602	Double-bevelled Oil control ring	
603	Coil Spring loaded Oil control ring	
604	Coil Spring loaded Bevelled-edge Oil control ring	
605	Coil Spring loaded Double-bevelled Oil control ring	
606	Coil Spring loaded Internal Bevelled-edge Oil control ring	
700	RIK-VENT, Expander Oil control ring	



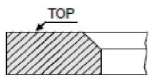
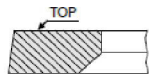
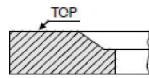
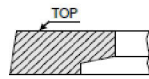
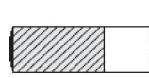
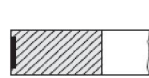





2) Edge and Face configurations



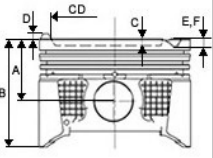



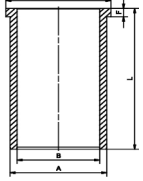

IF	Internal bevel top	
IFU	Internal bevel bottom	
IW	Internal step top	
IWU	Internal step bottom	
B	Barrel faced	
N	Coated Inlaid faced	



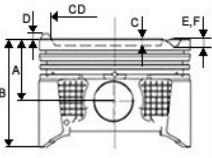



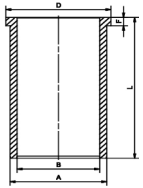

3) Coating and Material configurations



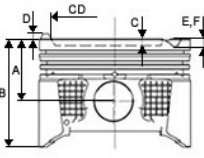





Cr	Surface chromium plating
Cr3	Side chromium plating
Cr4	Full chromium plating
Mo	Surface molybdenum plating
Nit	Nitriding
PI	Plasma spray coating



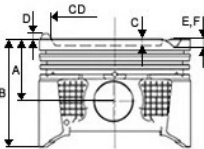





QBCr	"Quick Break-In" chromium plating
IP	Ion Plating
Fe	Ferrox treatment
P	Phosphate treatment
S	Steel material



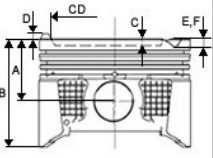



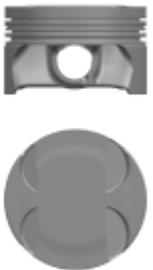
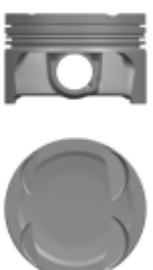

Motor /Engine	Ref. No. Kit 1	Ölçüler /Dimensions	Segman /Rings	Pim	Gömlek /Liner	Kit 2	Info
							
ø69,60 4 Cyl. Diesel 1248cc 75 HP 55/70 KW 75/95 PS B13 DTE/DTR 1.3 CDTi (EUR 6) 2006 -..... 1.3 CDTi CORSA E Van (X15) CORSA E (X15) CORSAVAN Mk III (D) (S07) CORSAVAN MkIV E (X15) CORSAVAN Mk IV-€ (X15) MITO	18-2092260 STD 18-2092260-20 STD (-0.20 mm) 18-2092260-40 STD (-0.40 mm) 18-2092262 0.40 18-2092262-20 0.40 (-0.20 mm) 18-2092262-40 0.40 (-0.40 mm) 18-2092267 0.80 18-2092267-20 0.80 (-0.20 mm) 18-2092267-40 0.80 (-0.40 mm)	A = 40,430 B = 62,430 C = 12,000 CD= 42,300 Segman Taşıyıcı (Ring Carrier) Yag Galerisi (Oil Gallery) Yag Püskürt. Oyugu (Oil Cut-Out)	RE22860000 -STD RE22860040 -0.40 RE22860060 -0.60 RE22860080 -0.80 RE22860100 -1.00 1,500 (500) Cr P 1,500 (501) P 2,000 (604) Nit S	ø23,0 x 56,7	G69601420K_1 A= 72,500 B= 68,900 D= 74,000 F= 5,000 H= 0,000 L= 142,000 		
ø72,00 4 Cyl. Benzin 1368 cc 88/99/103/104 107/110/114/132 kW 120/135/140/141 145/150/155/180 PS 198A1.000 198A4.000 199 A8.000 940 B7.000 955 A2.0000 312 A3.000 Egea 1.4 16Valf -..... 198.A1.000 199.A8/A4.000 312.A3.000 940.B7.000 955.A2.000 Euro 5	18-2010230 STD 18-2010232 0.40	A = 26,800 B = 49,800 C = 5,700 E = -1,800 F = -2,600	RE22811000 -STD RE22811040 -0.40 1,200 (500) Cr P 1,200 (508) P 2,000 (700) Cr P S	ø18,0 x 53,0			

Motor /Engine	Ref. No. Kit 1	Ölçüler /Dimensions	Segman /Rings	Pim	Gömlek /Liner	Kit 2	Info
       							
ø79,50 4 Cyl. Diesel 1598 cc 70/74/77 84/85/88 KW 95/100/101 105/114/115 116/120 PS 16:5 1.6 16V Multi.jet (EURO 5) EJJ EJK 198 A2/A3.000 940/955 A3/C1/C5/A4.000 552 60 384/552 63 113 <u>2010 -</u> Bravo 1.6 16v Doblo II 1.6 16V Linea 1.616V FIAT Alfa Romeo Jeep Chrysler Lancia	18-2050040 STD 18-2050042 0.40	A = 43,950 B = 68,950 C = 13,800 E = -0,460 F = -0,600 CD= 41,700 Segman Taşıyıcı (Ring Carrier)	RE22880000 -STD RE22880040 -0.40 RE22880060 -0.60 1,500 (500) CrP 1,500 (508) P 2,000 (604) NitS	ø26,0 x 62,8			Deliksiz conta (0,82 mm) +0,02 +0,10 Tek delik conta (0,92 mm) +0,10 +0,20 İki delik conta +0,20 +0,30
ø83,00 4 Cyl. Diesel 1956 cc 81 125 KW 116 170Ps 16,5:1 198 A5.000 A/Y/Z 20DT/C/H/I/L 939B 5.000/940A 5.000 A5 198/940 <u>2008 -</u> Freemont Astra J Insignia 2.0 CDTI 16V Zafira MK III 2.0 CDTI Doblo 2.0 JTD Alfa Romeo Chrysler Lancia Saab Vauxhall Holden	18-2092650 STD 18-2092653 0.50	A = 46,630 B = 72,630 C = 15,800 E = -1,171 F = -1,220 CD= 43,500 Segman Taşıyıcı (Ring Carrier) Yag Galerisi (Oil Gallery)	RE43510000 -STD RE43510040 -0.40 RE43510050 -0.50 1,500 (500) Cr P 1,500 (508) P 2,000 (604) Nit S	ø30,0 x 67,0	G86001550K_1 A= 86,000 B= 82,300 D= 87,500 F= 5,000 H= 0,000 L= 155,000 		

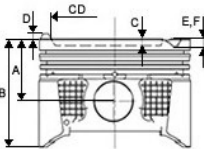





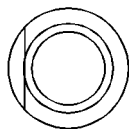
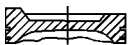

							
Motor /Engine	Ref. No. Kit 1	Ölçüler /Dimensions	Segman /Rings	Pim	Gömlek /Liner	Kit 2	Info
<p>ø83,00</p> <p>4 Cyl. Benzin AR 32310</p> <p>156 (932): 2.0 16V T.SPARK (932A21__)</p>	<p>18-9510010 STD 18-9510012 0.40</p>	<p>A = 31,300 B = 51,300 C = 3,800 CD= 69,000</p> <p>Sac Plaka (Steel Support)</p>	<p>RE11250000 -STD RE11250040 -0.40</p> <p>1,200 (500) Nit S IF 1,200 (508) P 2,000 (700) Nit S</p>	<p>ø21,0 x 57,0</p>			

							
Motor /Engine	Ref. No. Kit 1	Ölçüler /Dimensions	Segman /Rings	Pim	Gömlek /Liner	Kit 2	Info
<p>ø69,50</p> <p>4 Cyl. Benzin, 895 cm³ 29,5 kW (40 hp), 8:1 FA FJ GG HB <u>1974 -....</u></p> <p><i>Golf Polo Jetta Audi 50</i></p> 	<p>18-7010010 STD 18-7010013 0.50</p>	<p>A = 40,200 B = 67,000 C = 4,000</p>	<p>RE53050000 -STD RE53050050 -0.50</p> <p>1,500 (500) Cr S 1,500 (501) P 3,000 (700) Cr S P</p>	<p>ø20,0 x 54,0</p>			
<p>ø71,00</p> <p>4 Cyl. Benzin 1197 63/66/77 Kw 8690//105 Ps CBZA CBZB CBZC <u>2010 -</u></p> <p><i>Golf Jetta Polo</i></p>	<p>18-7010020 STD 18-7010023 0.50</p>	<p>A = 28,900 B = 45,000 C = 4,400</p>	<p>RE49730000 -STD RE49730025 -0.25 RE49730050 -0.50</p> <p>1,000 (500) NitB S 1,200 (501) Cr P 2,000 (700) Nit S</p>	<p>ø19,0 x 42,0</p>			

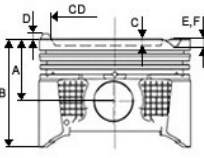
Motor /Engine	Ref. No. Kit 1	Ölçüler /Dimensions	Segman /Rings	Pim	Gömlek /Liner	Kit 2	Info
       							
ø71,00 4 Cyl. Benzin 1197 cc Fit EA211 1.2 TSI L4 Turbocharged CJZA CYVB CYVD CYVC CJZ CYV <u>2013 - 2021</u> A3 (8V) BEETLE CADYY-GOLF(MK7) JETTA POLO (6R) TOURAN FABIA OCTAVIA RAPID YETI IBIZA LEON TOLEDO	18-7010710 STD 18-7010713 0.50	A = 27,800 B = 44,400 D = 0,500 E = -2,900 F = -4,000 Sert Anotlama (Hard Anodising)		ø17,0 x 47,5			
							
ø74,50 4 Cyl. Benzin GÜÇLENDİRİLMİŞ CZD CZD A/B CZC CZC A/B/C CXS CPV CPV A/B/C 1.4 TSI TFSI (Yeni Triger Kayışı EA211)	18-7010700 STD 18-7010703 0.50	A = 30,800 B = 47,800 C = 1,850 E = -2,750 F = -4,500 CD= 60,600 Segman Taşıyıcı (Ring Carrier)		ø19,0 x 50,0			
							

							
Motor /Engine	Ref. No. Kit 1	Ölçüler /Dimensions	Segman /Rings	Pim	Gömlek /Liner	Kit 2	Info
<p>ø75,00</p> <p>4 Cyl. Benzin 1043 cc 33 Kw (45 Ps) 9.8: AAU <u>1990 - 1994</u></p> <p><i>Golf Polo Vento (1990-1994)</i></p>	<p>18-7010360 STD</p>	<p>A = 47,370 B = 73,500 C = 6,800 CD= 1,000</p> <p>Sac Plaka (Steel Support)</p>	<p>RE56070000 -STD</p> <p>1,500 (500) CrB Fe S IF 1,500 (501) P 2,500 (700) Cr P S</p>	<p>ø20,0 x 50,0</p>			
<p>ø75,00</p> <p>4 Cyl. Benzin 1391 cc 44 kW 60 PS 9,2:1 ABD <u>1991 - 1995</u></p> <p><i>GIII 1.4 60 CV</i></p>	<p>18-7010550 STD 18-7010553 0.50</p>	<p>A = 34,520 B = 56,520 C = 15,220 E = -1,650</p>	<p>RE56070000 -STD</p> <p>1,500 (500) CrB Fe S IF 1,500 (501) P 2,500 (700) Cr P S</p>	<p>ø17,0 x 48,0</p>			





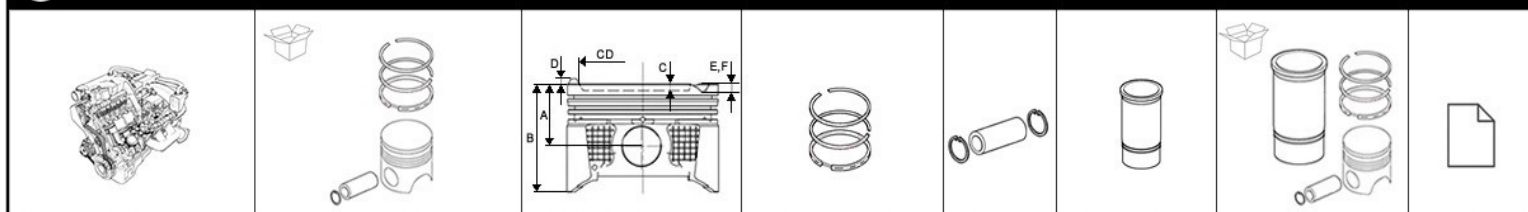







							
Motor /Engine	Ref. No. Kit 1	Ölçüler /Dimensions	Segman /Rings	Pim	Gömlek /Liner	Kit 2	Info
<p>ø76,50</p> <p>4 Cyl. Benzin 1390cc 103 Kw (140/170 Hp) GÜÇLENDİRİLMİŞ BMY BLG CAVD <u>2006 -....</u></p> <p><i>GOLF 1,4 TSI JETTA 1,4 TSI Jetta 1.4TSI16V Touran 1.4FSI16V Touran 1.4 TSI16V Golf Plus 1.4TSI16V Golf V 1.4FSI+TSI16V Tiguan 1.4TSI16V Scirocco 1.4TSI16V Beetle 1.4TSI</i></p>	<p>18-7010280 STD 18-7010280-30 STD 18-7010283 0.50 18-7010283-30 0.50</p>	<p>A = 29,000 B = 48,000 C = 4,550 D = 1,850 E = -1,000 F = -3,800</p> <p>Segman Taşıyıcı (Ring Carrier)</p> <p>Sert Anotlama (Hard Anodising)</p>	<p>RE56200000 -STD RE56200050 -0.50</p> <p>1,200 (500) NitBS 1,500 (501) P 2,000 (700) NitS</p>	<p>ø19,0 x 54,0</p>			
<p>ø76,50</p> <p>4 Cyl. Benzin 1390 cc 40 44 Kw (54 60 Ps) AEX <u>1995 - 1997</u></p> <p><i>Golf Polo Vento/1389 cc</i></p>	<p>18-7010530 STD 18-7010533 0.50</p>	<p>A = 28,350 B = 50,350 C = 5,900</p>	<p>RE56310000 -STD RE56310050 -0.50</p> <p>1,200 (500) NitB S IF 1,500 (508) P 2,500 (700) Cr P S</p>	<p>ø17,0 x 52,0</p>			

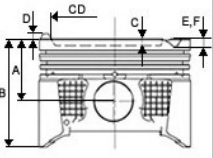





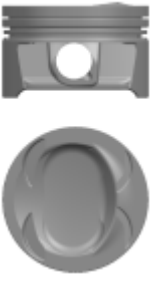
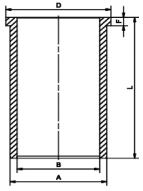





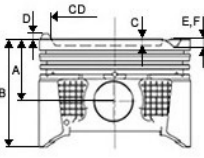





Motor /Engine	Ref. No. Kit 1	Ölçüler /Dimensions	Segman /Rings	Pim	Gömlek /Liner	Kit 2	Info
---------------	----------------	---------------------	---------------	-----	---------------	-------	------



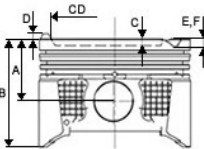





ø76,50 4 Cyl. Benzin 1390 cc 74 Kw (100 Ps) AFH AFK AHW AKQ ANM AQQ AUB AUA AXP <u>1996 -....</u> Audi A2 1.4 Fabia Octavia	18-7010620 STD 18-7010623 0.50	A = 28,920 B = 49,920 C = 1,980 E = -2,323 CD= 61,900	RE56310000 -STD RE56310050 -0.50 1,200 (500) NitB S IF 1,500 (508) P 2,500 (700) Cr P S	ø17,0 x 54,0			
							



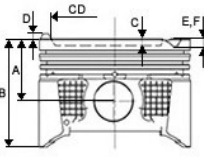



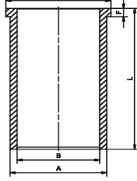
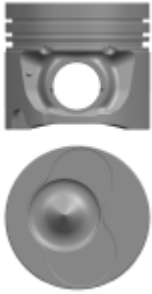

ø76,50 4 Cyl. Benzin 1390cc 90 92 KW(122 125 BG) CAX CAXA CMSA <u>2007 -....</u> VW EOS 1.4FSI16V VW Golf Plus 1.4FSI16V Golf V 1.4FSI16V Golf V 1.4TFSI16V Golf V 1.4TFSI16V Jetta 1.4FSI16V Passat 1.4FSI16V Scirocco 1.4TFSI16V	18-7010630 STD 18-7010633 0.50	A = 29,200 B = 48,200 C = 4,500 E = -3,600 F = -0,700 Sert Anotlama (Hard Anodising)	RE56450000 -STD RE56450050 -0.50 1,200 (500) NitB S 1,200 (501) P 2,000 (700) Nit S	ø19,0 x 52,0			
							



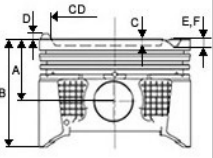



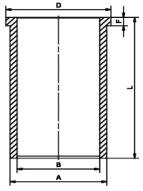

Motor /Engine	Ref. No. Kit 1	Ölçüler /Dimensions	Segman /Rings	Pim	Gömlek /Liner	Kit 2	Info
       							
ø76,50 4 Cyl. Benzin 1390cc 103 KW (170 Ps) BMY BLG CAVD 2006 -..... Jetta 1.4TSI16V Touran 1.4FSI16V Touran 1.4 TSI16V Golf Plus 1.4TSI16V Golf V 1.4FSI+TSI16V Tiguan 1.4TSI16V Scirocco 1.4TSI16V Beetle 1.4TSI	18-7010640 STD 18-7010643 0.50	A = 29,000 B = 48,200 C = 5,900 D = 1,850 E = -1,100 F = -3,900 Sert Anotlama (Hard Anodising)	RE56200000 -STD RE56200050 -0.50 1,200 (500) NitBS 1,500 (501) P 2,000 (700) NitS	ø19,0 x 52,0			
							
ø76,50 4 Cyl. Diesel 1588 cc 2383 cc 37/40/44/51 /55/57/60,5 Kw (50/54/60/69/75/78/82 Ps) D24 ADK CR JK JP CY JR JX MF ATC 1S CP DW 751 1980 - 1992 Volvo 240D/244D/245D/740D Golf Polo Bora Audi 80 1.6D/TD Audi 90 1.6TD Audi 100 2.0D/TD Audi 100 2.4TD SKODA	18-7050760 STD 18-7050763 0.50	A = 41,700 B = 71,700 C = 1,600 Segman Taşıyıcı (Ring Carrier) Sac Plaka (Steel Support)	RE56110000 -STD RE56110050 -0.50 RE56110100 -1.00 1,750 (500) CrB Fe S 2,000 (501) Cr IFU 3,000 (604) Cr	ø24,0 x 64,0	G79501420K_1 A= 79,500 B= 75,810 D= 82,500 F= 4,700 H= 0,000 L= 142,000 	1. çentik 1.40 mm conta + 0,67 + 0,80 2. çentik 1.50 mm conta + 0,81 + 0,90 3. çentik 1.60 mm conta + 0,91 + 1,02	
							



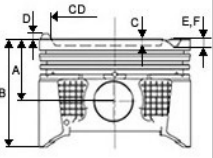



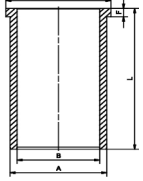
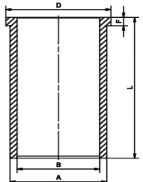

							
Motor /Engine	Ref. No. Kit 1	Ölçüler /Dimensions	Segman /Rings	Pim	Gömlek /Liner	Kit 2	Info
<p>ø76,51</p> <p>4 Cyl. Diesel 1588 cc 59 Kw (80 Ps) 23:1 RA SBDE <u>1989 - 1993</u></p> <p><i>Golf Jetta Passat 1989 - 1993</i></p>	<p>18-7081140 STD 18-7081143 0.50 18-7081148 1.00</p>	<p>A = 41,700 B = 71,700 C = 1,600</p> <p>Segman Taşıyıcı (Ring Carrier)</p> <p>Sert Anotlama (Hard Anodising)</p> <p>Sac Plaka (Steel Support)</p> <p>Yag Püskürt. Oyugu (Oil Cut-Out)</p>	<p>RE56100000 -STD RE56100050 -0.50 RE56100100 -1.00</p> <p>1,750 (500) CrB Fe S 2,000 (501) P IFU 3,000 (604) Cr</p>	<p>ø24,0 x 64,0</p>			<p>1.çentik 1.53 mm conta +0,66 +0,80</p> <p>2.çentik 1.57 mm conta +0,81 +0,90</p> <p>3.çentik 1.61 mm conta +0,91 +1,02</p>
<p>ø78,30</p> <p>6 Cyl. Diesel 2496 cc 110kW 150PS 19.5:1 AKN AK KK RT <u>1997 - 2005</u></p> <p><i>1.2.3. Sil. PASSAT A4 2.5 TDI 78.31 MM</i></p>	<p>17-7050580 STD 17-7050583 0.50</p>	<p>A = 47,830 B = 71,830 C = 16,500 E = -1,380 CD= 35,800</p>	<p>RE12160000 -STD RE12160025 -0.25 RE12160050 -0.50 RE12160100 -1.00</p> <p>1,200 (500) NitB S IF 1,500 (501) P 2,000 (700) CrPS</p>	<p>ø26,0 x 65,5</p>			



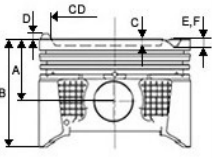



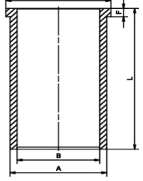
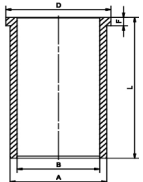

							
Motor /Engine	Ref. No. Kit 1	Ölçüler /Dimensions	Segman /Rings	Pim	Gömlek /Liner	Kit 2	Info
<p>ø78,30</p> <p>6 Cyl. Diesel 2496 cc 110kW 150PS 19.5:1 AKN AK KK RT <u>1997 - 2005</u></p> <p>4.5. Sil.PASSAT A4 2.5 TDI 78.31 MM</p>	<p>17-7050590 STD 17-7050593 0.50</p>	<p>A = 47,830 B = 71,830 C = 16,500 E = -1,380 CD= 35,800</p>	<p>RE12160000 -STD RE12160025 -0.25 RE12160050 -0.50 RE12160100 -1.00</p> <p>1,200 (500) NitB S IF 1,500 (501) P 2,000 (700) CrPS</p>	<p>ø26,0 x 65,5</p>			
<p>ø79,50</p> <p>4 Cyl. Diesel 1896/... cc 85 Kw 115 Ps 18:1 19:1 Turbo,LLK,8 Ventile AJM ATJ AUY BVK 1.&2.Sil <u>1988 -....</u></p> <p>1.&2.Sil A4/A6 1.9 TDI Turbo-LLK-8 Ventile GALAXY I 1.9 TDI ALHAMBRA 1.9 TDI GOLF IV BORA PASSAT SHARAN I 1.9 TDI</p>	<p>18-7050020 STD 18-7050023 0.50 18-7050028 1.00</p>	<p>A = 45,800 B = 69,800 C = 17,800 E = -1,300 F = -1,300 CD= 38,000</p>	<p>RE56160000 -STD RE56160050 -0.50 RE56160100 -1.00</p>	<p>ø26,0 x 66,0</p>			



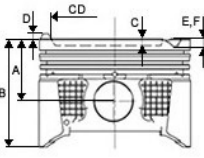





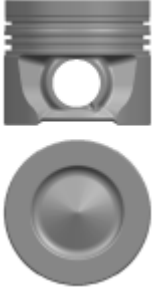
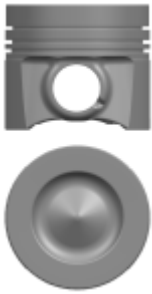

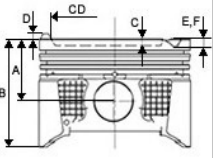

							
Motor /Engine	Ref. No. Kit 1	Ölçüler /Dimensions	Segman /Rings	Pim	Gömlek /Liner	Kit 2	Info
<p>ø79,50</p> <p>4 Cyl. Diesel 1896/... cc 85 Kw 115 Ps 18:1 19:1 Turbo,LLK,8 Ventile AJM ATJ AUY BVK 3.&4.Sil <u>1988 -....</u></p> <p>1. & 2. Sil A4/A6 1.9 TDI Turbo-LLK-8 Ventile GALAXY I 1.9 TDI ALHAMBRA 1.9 TDI GOLF IV BORA PASSAT SHARAN I 1.9 TDI</p>	<p>18-7050030 STD 18-7050033 0.50 18-7050038 1.00</p>	<p>A = 45,800 B = 69,800 C = 17,800 E = -1,300 F = -1,300 CD= 38,000</p>	<p>RE56160000 -STD RE56160050 -0.50 RE56160100 -1.00</p>	<p>ø26,0 x 66,0</p>	<p>G83001548K_1</p> <p>A= 83,000 B= 78,810 D= 85,600 F= 5,100 H= 0,000 L= 154,800</p> 		
<p>ø79,50</p> <p>3 Cyl. Diesel 1422 cc 55 Kw (75 Ps) 19.5:1 AMF BAY BWB BHC BNV <u>1999 -....</u></p> <p>1. & 2. Sil Polo 1.4 Tdi Lupo 1.4 Tdi Fox 1.4 Tdi Fabiá 1.4 TDi</p>	<p>17-7050880 STD 17-7050883 0.50</p> 	<p>A = 45,800 B = 69,800 C = 17,650 E = -1,100 CD= 37,900</p> <p>Segman Taşıyıcı (Ring Carrier)</p> <p>Yag Püskürt. Oyugu (Oil Cut-Out)</p> <p>Burc (Bushing)</p>	<p>RE56160000 -STD RE56160050 -0.50 RE56160100 -1.00</p> <p>1,750 (500) CrB Fe S 2,000 (501) P IFU 3,000 (604) Cr P S</p>	<p>ø26,0 x 63,0</p>			<p>1,53 mm conta + 0,81 + 0,96</p> <p>1,57 mm conta + 0,96 + 1,01</p> <p>1,61 mm conta + 1,01 + 1,03</p>









Motor /Engine	Ref. No. Kit 1	Ölçüler /Dimensions	Segman /Rings	Pim	Gömlek /Liner	Kit 2	Info
       							
ø79,50 3 Cyl. Diesel 1422 cc 55 Kw (75 Ps) 19.5: AMF 1999 -.... 3. Sil. Polo 1,4 Tdi Lupo 1,4 Tdi Fox 1,4 Tdi Fabia 1.4 TDi	17-7050890 STD 17-7050893 0.50	A = 45,800 B = 69,800 C = 17,650 E = -1,100 CD= 37,900 Segman Taşıyıcı (Ring Carrier) Yag Püskürt. Oyugu (Oil Cut-Out) Burc (Bushing)	RE56160000 -STD RE56160050 -0.50 RE56160100 -1.00 1,750 (500) CrB Fe S 2,000 (501) P IFU 3,000 (604) Cr P S	ø26,0 x 63,0			1,53 mm conta + 0,81 + 0,96 1,57 mm conta + 0,96 + 1,01 1,61 mm conta + 1,01 + 1,03
ø79,50 4/5 Cyl. Diesel 1896 cc 44 Kw (60 Ps) 22.5:1 ADG AEF BGG 1 X 1 Y(4 CY) AAB AJA (5 CYL) 1990 - 1995 Golf Polo Passat Caddy Transporter T4 Audi 80 1.9D Audi 100 2.4D Skoda Felica 1.9D	17-7050920 STD 17-7050923 0.50 17-7050928 1.00	A = 39,650 B = 65,700 C = 1,900 Segman Taşıyıcı (Ring Carrier) Sac Plaka (Steel Support) Yag Püskürt. Oyugu (Oil Cut-Out)	RE56160000 -STD RE56160050 -0.50 RE56160100 -1.00 1,750 (500) CrB Fe S 2,000 (501) P IFU 3,000 (604) Cr P S	ø24,0 x 64,0	G83001548K_1 A= 83,000 B= 78,810 D= 85,600 F= 5,100 H= 0,000 L= 154,800		1. çentik 1.53 mm conta + 0,66 + 0,86 2. çentik 1.57 mm conta + 0,87 + 0,90 3. çentik 1.61 mm conta + 0,91 + 1,02



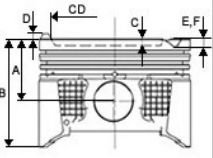





Motor /Engine	Ref. No. Kit 1	Ölçüler /Dimensions	Segman /Rings	Pim	Gömlek /Liner	Kit 2	Info
							
ø79,50 4 Cyl. Diesel 1896 cc 50 Kw (68 Ps) 22.5:1 AAZ ABL ADE 1992 -..... Transporter T4 Passat 1,9 TD Golf III 1,9 TD Vento 1,9 TD Audi 80 1.9 TD	18-7050940 STD 18-7050943 0.50 18-7050948 1.00	A = 45,650 B = 71,700 C = 1,900	RE56330000 -STD RE56330050 -0.50 RE56330100 -1.00 1,750 (500) CrB Fe S 2,000 (501) Cr P IFU 3,000 (604) Cr P S	ø26,0 x 66,0	G83001548K_1 A= 83,000 B= 78,810 D= 85,600 F= 5,100 H= 0,000 L= 154,800		1.çentik 1.53 mm conta +0,66 +0,86 2.çentik 1.57 mm conta +0,87 +0,90 3.çentik 1.61 mm conta +0,91 +1,02
ø79,50 4 Cyl. Diesel 1896 cc 66 Kw (90 Ps) 19.5:1 1Z AGD AEY AHH AHU AFN AHF 1993 - 1997 1. & 2. Sil. Vento 1,9 Tdi Passat 1,9 Tdi Bora 1,9 Tdi Golf III 1,9 Tdi A3 1,9 Tdi A4 1,9 Tdi A6 1,9 Tdi Cabriolet 1,9 Tdi Audi 80 1,9 Tdi Skoda Sporb Tdi Skoda Octavia Tdi	17-7050950 STD 17-7050953 0.50 17-7050958 1.00	A = 45,800 B = 71,800 C = 17,650 E = -1,100 CD= 37,900	RE56160000 -STD RE56160050 -0.50 RE56160100 -1.00 1,750 (500) CrB Fe S 2,000 (501) P IFU 3,000 (604) Cr P S	ø26,0 x 66,0	G83001548K_1 A= 83,000 B= 78,810 D= 85,600 F= 5,100 H= 0,000 L= 154,800		1. çentik 1.45 mm conta + 0,91 + 1,00 2. çentik 1.53 mm conta + 1,00 + 1,10 3. çentik 1.61 mm conta + 1,10 + 1,20



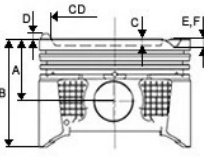



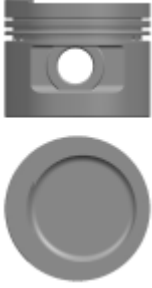
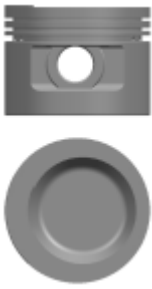

Motor /Engine	Ref. No. Kit 1	Ölçüler /Dimensions	Segman /Rings	Pim	Gömlek /Liner	Kit 2	Info
							
ø79,50 4 Cyl. Diesel 1896 cc 66 Kw (90 Ps) 19.5:1 1Z AGD AEY AHH AHU AFN AHF 1993 - 1997 3. & 4. Sil. Vento 1.9 Tdi Passat 1.9 Tdi Bora 1.9 Tdi Golf III 1.9 Tdi A3 1.9 Tdi A4 1.9 Tdi A6 1.9 Tdi Cabriolet 1.9 Tdi Audi 80 1.9 Tdi Skoda Spërb Tdi Skoda Octavia Tdi	17-7050960 STD 17-7050963 0.50 17-7050968 1.00	A = 45,800 B = 71,800 C = 17,650 E = -1,100 CD= 37,900 Segman Taşıyıcı (Ring Carrier) Yag Püskürt. Oyugu (Oil Cut-Out) Burc (Bushing)	RE56160000 -STD RE56160050 -0.50 RE56160100 -1.00 1,750 (500) CrB Fe S 2,000 (501) P IFU 3,000 (604) Cr P S	ø26,0 x 66,0	G83001548K_1 A= 83,000 B= 78,810 D= 85,600 F= 5,100 H= 0,000 L= 154,800 	1. çentik 1.45 mm conta + 0,91 + 1,00 2. çentik 1.53 mm conta + 1,00 + 1,10 3. çentik 1.61 mm conta + 1,10 + 1,20	
ø79,50 4 Cyl. Diesel 1598cc 77KW 105HP CLHA CLHB CRKB 2010 - A3 1.6 TDI 16V GOLF VII 1.6 TDI Leon 1.6 TDI Octavia 1.6 TDI 2010 -	18-7092090 STD 18-7092093 0.50	A = 45,300 B = 68,130 C = 11,000 CD= 49,000 Segman Taşıyıcı (Ring Carrier) Yag Galerisi (Oil Gallery) Yag Püskürt. Oyugu (Oil Cut-Out)	RE56140000 -STD RE56140050 -0.50 1,750 (500) Cr P 2,000 (501) P IF 2,000 (604) Nit S	ø26,0 x 66,0	G83001548K_1 A= 83,000 B= 78,810 D= 85,600 F= 5,100 H= 0,000 L= 154,800 		



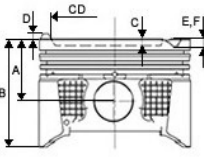





							
Motor /Engine	Ref. No. Kit 1	Ölçüler /Dimensions	Segman /Rings	Pim	Gömlek /Liner	Kit 2	Info
<p>ø79,51</p> <p>3/4 Cyl. Diesel 1199 cc/1598cc 55/66 77 Kw 75/90/102/105 ps CAYB CAYC CFWA CLNA CAYA CAYD CAYE CFWA <u>2009 -....</u></p> <p><i>Polo 1.2 Tdi (3 cyl) Polo 1.6 TDI 16V 4 cyl 2009 - 2014</i></p>	<p>17-7092500 STD <i>17-7092500-20 STD (-0.20 mm)</i> 17-7092503 0.50 <i>17-7092503-20 0.50 (-0.20 mm)</i></p> 	<p>A = 45,300 B = 67,900 C = 10,700 CD= 49,000</p> <p>Segman Taşıyıcı (Ring Carrier)</p> <p>Yag Galerisi (Oil Gallery)</p>	<p>RE56160000 -STD RE56160050 -0.50 RE56160100 -1.00</p> <p>1,750 (500) CrB Fe S 2,000 (501) P IFU 3,000 (604) Cr P S</p>	<p>ø26,0 x 66,0</p>			
<p>ø79,51</p> <p>3 Cyl. Diesel 1422 cc 55/66/77 KW 75/90/105 PS CUSB CUSA CUTA CYZA CYZB <u>2014 -</u></p> <p><i>Polo 14 TDI</i></p>	<p>17-7092600 STD <i>17-7092600-20 STD (-0.20 mm)</i> 17-7092603 0.50 <i>17-7092603-20 0.50 (-0.20 mm)</i></p> 	<p>A = 45,800 B = 68,800 C = 13,600 CD= 49,000</p> <p>Segman Taşıyıcı (Ring Carrier)</p> <p>Yag Galerisi (Oil Gallery)</p>	<p>RE12320000 -STD RE12320050 -0.50</p> <p>1,750 (500) CrP 2,000 (501) PIFU 2,000 (604) CrP</p>	<p>ø26,0 x 66,0</p>			



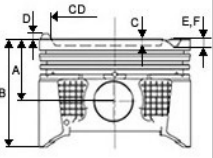



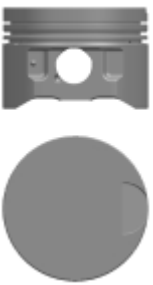

Motor /Engine	Ref. No. Kit 1	Ölçüler /Dimensions	Segman /Rings	Pim	Gömlek /Liner	Kit 2	Info
							
ø79,51 4 Cyl. Diesel 1896 cc 74 Kw (101 Ps) AVQ ATD AXR AVB BJB SERİSİ OIL GALERY VAR 2004 -.... 1.ve 2. Sil. Caddy III TDI Touran TDI Bora TDI Golf TDI Polo TDI Passat TDI	17-7092750 STD 17-7092753 0.50	A = 45,800 B = 68,800 C = 17,100 E = -0,650 CD= 38,000 Segman Taşıyıcı (Ring Carrier) Yag Galerisi (Oil Gallery) Yag Püskürt. Oyugu (Oil Cut-Out) Burc (Bushing)	RE56330000 -STD RE56330050 -0.50 RE56330100 -1.00 1,750 (500) CrB Fe S 2,000 (501) Cr P IFU 3,000 (604) Cr P S	ø26,0 x 66,0		 	1,45 mm conta +0,91 +1,00 1,53 mm conta +1,01 +1,10 1,61 mm conta +1,11 +1,20
ø79,51 4 Cyl. Diesel 1896 cc 74 Kw (101 Ps) AVQ ATD AXR AVB BJB SERİSİ OIL GALERY VAR 2004 -.... 3.ve 4. Sil. Caddy III TDI Touran TDI Bora TDI Golf TDI Polo TDI Passat TDI	17-7092760 STD 17-7092763 0.50	A = 45,800 B = 68,800 C = 17,100 E = -0,650 CD= 38,000 Segman Taşıyıcı (Ring Carrier) Yag Galerisi (Oil Gallery) Yag Püskürt. Oyugu (Oil Cut-Out) Burc (Bushing)	RE56330000 -STD RE56330050 -0.50 RE56330100 -1.00 1,750 (500) CrB Fe S 2,000 (501) Cr P IFU 3,000 (604) Cr P S	ø26,0 x 66,0		 	1,45 mm conta +0,91 +1,00 1,53 mm conta +1,01 +1,10 1,61 mm conta +1,11 +1,20



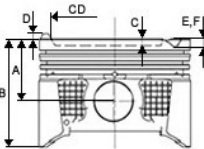



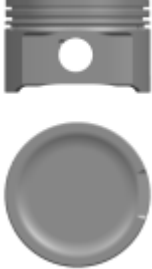
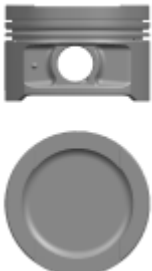

Motor /Engine	Ref. No. Kit 1	Ölçüler /Dimensions	Segman /Rings	Pim	Gömlek /Liner	Kit 2	Info
       							
ø79,51 4 Cyl. Diesel 1896 cc 110 Kw (150 Ps) ARL ASZ AXB AXC AXB EUR3 2000 -..... 1. & 2. Sil. Bora PDI Golf PDI Bora TDI Golf TDI Multi Van Transporter Transporter TDI	17-7092770 STD 17-7092773 0.50	A = 45,800 B = 68,800 C = 17,900 E = -1,100 CD= 38,000 Segman Taşıyıcı (Ring Carrier) Yag Galerisi (Oil Gallery) Yag Püskürt. Oyugu (Oil Cut-Out) Burc (Bushing)	RE56160000 -STD RE56160050 -0.50 RE56160100 -1.00 1,750 (500) CrB Fe S 2,000 (501) P IFU 3,000 (604) Cr P S	ø26,0 x 66,0			1,45 mm conta +0,91 +1,00 1,53 mm conta +1,01 +1,10 1,61 mm conta +1,11 +1,20
ø79,51 4 Cyl. Diesel 1896 cc 110 Kw (150 Ps) ARL ASZ AXB AXC AXB EUR3 2000 -..... 3. & 4. Sil. Bora PDI Golf PDI Bora TDI Golf TDI Multi Van Transporter Transporter TDI	17-7092780 STD 17-7092783 0.50	A = 45,800 B = 68,800 C = 17,900 E = -1,100 CD= 38,000 Segman Taşıyıcı (Ring Carrier) Yag Galerisi (Oil Gallery) Yag Püskürt. Oyugu (Oil Cut-Out) Burc (Bushing)	RE56160000 -STD RE56160050 -0.50 RE56160100 -1.00 1,750 (500) CrB Fe S 2,000 (501) P IFU 3,000 (604) Cr P S	ø26,0 x 66,0			



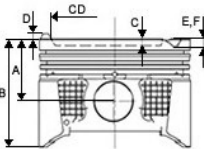



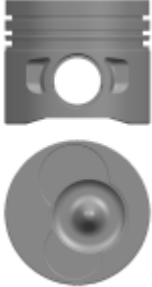
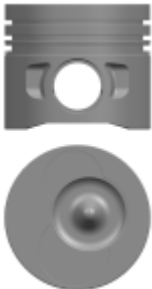

							
Motor /Engine	Ref. No. Kit 1	Ölçüler /Dimensions	Segman /Rings	Pim	Gömlek /Liner	Kit 2	Info
<p>ø81,00</p> <p>4 Cyl. Benzin, 1595 cm³ 53/55 kW (72/75 hp)</p> <p>ABN DT EW EZ ABX ACR DTA EZA HM</p> <p><u>1991 -....</u></p> <p>Golf Jetta Passat Audi 80 1.6</p> 	<p>18-7010160 STD 18-7010163 0.50</p>	<p>A = 35,600 B = 58,500 C = 2,300 D = 0,700</p>	<p>RE56180000 -STD RE56180050 -0.50 RE56180100 -1.00</p> <p>1,500 (500) CrB S IF 1,750 (508) P 3,000 (700) Cr P S</p>	<p>ø20,0 x 57,0</p>			
<p>ø81,00</p> <p>4 Cyl. Benzin, 1781 cm³ 55 kW (75 hp)</p> <p>AMM ANN ACC ADD RP</p> <p><u>1983 - 1996</u></p> <p>Golf 1.8 Jetta II 1.8 Passat 1.8 Audi 80 1.8 audi 80 1.8 cc Audi 80 1.8 s Audi 100 1.8 Audi Coupe 1.8 Audi Coupe 1.8 GT</p> 	<p>18-7010170 STD 18-7010173 0.50</p>	<p>A = 32,200 B = 62,500 C = 8,100 D = 1,300 CD= 56,800</p>	<p>RE56190000 -STD RE56190050 -0.50</p> <p>1,500 (500) CrB S IF 1,750 (508) P 3,000 (604) Cr</p>	<p>ø20,0 x 57,0</p>			



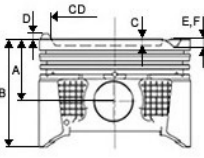



							
Motor /Engine	Ref. No. Kit 1	Ölçüler /Dimensions	Segman /Rings	Pim	Gömlek /Liner	Kit 2	Info
<p>ø81,00</p> <p>5 Cyl. Benzin, 2226 cm³ 101 kW (137 hp), 10:1 HY KV JT KX KM <u>1984 - 1990</u> Passat</p>	<p>17-7010200 STD</p>	<p>A = 32,200 B = 62,300 C = 4,600 D = 1,100 CD= 60,000</p> <p>Sac Plaka (Steel Support)</p>	<p>RE56180000 -STD RE56180050 -0.50 RE56180100 -1.00</p> <p>1,500 (500) CrB S IF 1,750 (508) P 3,000 (700) Cr P S</p>	<p>ø20,0 x 57,0</p>			
<p>ø81,00</p> <p>4 Cyl. Benzin 1781 cc 72 Kw (98 Ps) ABS ADZ DS DX DZ EV GZ HT <u>1988 - 1991</u> Golf I 1.8i Jetta II 1.8 Passat 1.8 Audi 80 1.8 Audi 100 1.8 Quattro Coupe 1.8 GT</p>	<p>18-7010210 STD 18-7010213 0.50</p>	<p>A = 32,200 B = 62,500 C = 5,700 D = 1,300 CD= 55,700</p> <p>Sac Plaka (Steel Support)</p>	<p>RE56190000 -STD RE56190050 -0.50</p> <p>1,500 (500) CrB S IF 1,750 (508) P 3,000 (604) Cr</p>	<p>ø20,0 x 57,0</p>			

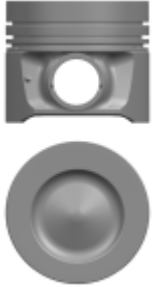
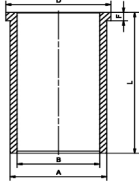
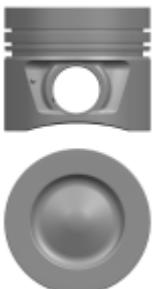
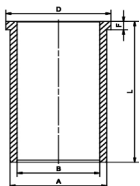



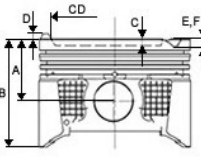
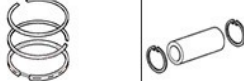

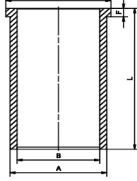
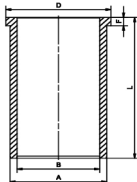

Motor /Engine	Ref. No. Kit 1	Ölçüler /Dimensions	Segman /Rings	Pim	Gömlek /Liner	Kit 2	Info
       							
ø81,00 4 Cyl. Benzin 1781 cc 110 Kw (150 Ps) AEB AGU AJH ANB APH APU AQA ARZ AVC <u>1996 -....</u> Golf VI 1,8 t Bora 1,8 t Passat 1,8 t Audi A3 I 1,8 T Audi A4 1,8 T Audi A6 1,8 T Audi TT 1,8 T Skoda Octavia Turbo	18-7010220 STD 18-7010221 0.25 18-7010223 0.50	A = 32,700 B = 53,700 C = 1,500 CD= 70,200	RE56380000 -STD RE56380025 -0.25 RE56380050 -0.50 RE56380100 -1.00 1,500 (500) CrBFeSIF 1,750 (508) P 2,000 (700) NitS	ø20,0 x 59,0			
							
ø81,00 4 Cyl. Benzin 1781 cc 92 Kw (125 Ps) AGN APT ARG AJP APG AQE ARH AVV <u>1996 -....</u> Golf VI 1,8 Bora 1,8 Passat 1,8 Audi A3 I 1,8 I Audi A4 1,8 Audi A6 1,8 Audi Cabriolet 1,8 I Skoda Octavia 20v	18-7010230 STD 18-7010233 0.50	A = 32,550 B = 56,550 E = -3,300 Yag Püskürt. Oyugu (Oil Cut-Out)	RE56380000 -STD RE56380025 -0.25 RE56380050 -0.50 RE56380100 -1.00 1,500 (500) CrBFeSIF 1,750 (508) P 2,000 (700) NitS	ø20,0 x 59,0			
							



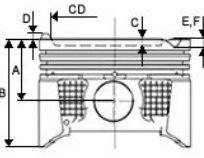





							
Motor /Engine	Ref. No. Kit 1	Ölçüler /Dimensions	Segman /Rings	Pim	Gömlek /Liner	Kit 2	Info
<p>ø81,00</p> <p>4 Cyl. Benzin 1781cc 110 Kw (150 Hp)</p> <p>ARX AUM AUQ AWM AWP AWT AWU AWV BJX BKF BNU AWP BE</p> <p><u>2000 - 2001</u></p> <p>Leon Toledo Ibiza Octavia Bora Golf IV Passat Jetta New Beetle</p> 	<p>18-7010250 STD 18-7010253 0.50</p>	<p>A = 32,700 B = 53,700 C = 1,900 CD= 69,200</p> <p>Sert Anotlama (Hard Anodising)</p> <p>Yag Püskürt. Oyugu (Oil Cut-Out)</p>	<p>RE56380000 -STD RE56380025 -0.25 RE56380050 -0.50 RE56380100 -1.00</p> <p>1,500 (500) CrBFeSIF 1,750 (508) P 2,000 (700) NitS</p>	<p>ø19,0 x 50,0</p>			
<p>ø81,00</p> <p>4 Cyl. Benzin 1595 cc 75 Kw (102 Ps)</p> <p>ADP AEH AEK AFT AHL AKL</p> <p><u>1996 - 1997</u></p> <p>Golf VI 1.6 Golf III 1.6 Passat 1.6 Vento 1.6 Audi A3cl 1.6 I Audi A4 1.6 Skoda Octavia</p> 	<p>18-7010350 STD 18-7010353 0.50 18-7010358 1.00</p>	<p>A = 32,000 B = 53,700 C = 3,000 E = -0,700 CD= 62,500</p>	<p>RE56370000 -STD RE56370050 -0.50 RE56370100 -1.00</p> <p>1,200 (500) NitB S IF 1,500 (508) P 2,000 (700) Nit S</p>	<p>ø20,0 x 57,0</p>			



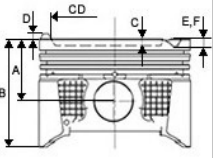





							
Motor /Engine	Ref. No. Kit 1	Ölçüler /Dimensions	Segman /Rings	Pim	Gömlek /Liner	Kit 2	Info
<p>ø81,00</p> <p>5 Cyl. Diesel, 2461 cm³ 88 kW (120 hp) AAT ABP AEL 1 T <u>1991-1996</u> 1. & 2.Sil. Audi 100 Tdi Audi A6 Tdi</p>	<p>17-7050860 STD 17-7050863 0.50</p>	<p>A = 45,750 B = 69,750 C = 17,250 E = -1,350</p> <p>Segman Taşıyıcı (Ring Carrier)</p> <p>Burc (Bushing)</p>	<p>RE12120000 -STD RE12120050 -0.50</p> <p>2,500 (500) Cr P 2,000 (501) P 3,000 (604) Cr P</p>	<p>ø26,0 x 68,0</p>			
<p>ø81,00</p> <p>5 Cyl. Diesel, 2461 cm³ 88 kW (120 hp) AAT ABP AEL 1 T <u>1991-1996</u> 3.&4.&5.Sil. Audi 100 Tdi Audi A6 Tdi</p>	<p>17-7050870 STD 17-7050873 0.50</p>	<p>A = 45,750 B = 69,750 C = 17,250 E = -1,350 CD= 39,600</p> <p>Segman Taşıyıcı (Ring Carrier)</p> <p>Burc (Bushing)</p>	<p>RE12120000 -STD RE12120050 -0.50</p> <p>2,500 (500) Cr P 2,000 (501) P 3,000 (604) Cr P</p>	<p>ø26,0 x 68,0</p>			



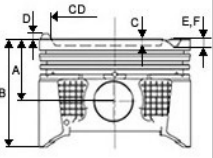





							
Motor /Engine	Ref. No. Kit 1	Ölçüler /Dimensions	Segman /Rings	Pim	Gömlek /Liner	Kit 2	Info
<p>ø81,00</p> <p>4 Cyl. Diesel 1968 cc 140 KW (190 PS) CNHA CNHC CZJA DETA DETB <u>2008 -....</u> AUDI 2.0TDI</p>	<p>18-7054320 STD 18-7054323 0.50</p> 	<p>A = 45,800 B = 68,800 C = 13,500 CD= 50,880</p> <p>Segman Taşıyıcı (Ring Carrier)</p> <p>Yag Galerisi (Oil Gallery)</p> <p>Burc (Bushing)</p>	<p>RK56281010010 -STD RK56281010013 -0.50</p> <p>1,750 () Cr 2,000 () IF 2,000 ()</p>	<p>ø26,0 x 66,0</p>	<p>G84001580K_1</p> <p>A= 84,000 B= 80,300 D= 85,000 F= 5,000 H= 0,000 L= 158,000</p> 		
<p>ø81,00</p> <p>4 Cyl. Diesel 2000 cc 100 120 KW/136 163 HP CKTC CKUC CKUB CKTB <u>2010 -....</u> Crafter 2.0 TDI Amarok 2010 -</p>	<p>18-7094400 STD 18-7094403 0.50</p> 	<p>A = 45,800 B = 68,800 C = 13,100 CD= 50,880</p> <p>Segman Taşıyıcı (Ring Carrier)</p> <p>Yag Galerisi (Oil Gallery)</p> <p>Yag Püskürt. Oyugu (Oil Cut-Out)</p> <p>Burc (Bushing)</p>	<p>RE56400000 -STD RE56400025 -0.25 RE56400050 -0.50 RE56400100 -1.00</p> <p>1,750 (500) CrB Fe S IF 2,000 (508) P 3,000 (604) Cr P</p>	<p>ø26,0 x 66,0</p>	<p>G84001580K_1</p> <p>A= 84,000 B= 80,300 D= 85,000 F= 5,000 H= 0,000 L= 158,000</p> 		



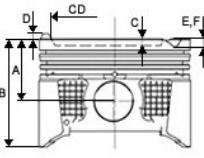





							
Motor /Engine	Ref. No. Kit 1	Ölçüler /Dimensions	Segman /Rings	Pim	Gömlek /Liner	Kit 2	Info
<p>ø81,00</p> <p>4 Cyl. Diesel 1968 cc 100 103 KW/136 140 PS BGW BMM BMP BRT BSS <u>2003 -....</u></p> <p><i>1. & 2. Sil. Caddy III BOX 2.0 TDI Golf VI 2.0 TDI Jetta III 2.0 TDI 2003 -</i></p>	<p>17-7094770 STD 17-7094773 0.50</p>	<p>A = 45,000 B = 68,800 C = 17,500 E = -0,700 CD= 38,000</p> <p>Segman Taşıyıcı (Ring Carrier)</p> <p>Yag Galerisi (Oil Gallery)</p> <p>Yag Püskürt. Oyugu (Oil Cut-Out)</p> <p>Burc (Bushing)</p>	<p>RE56400000 -STD RE56400025 -0.25 RE56400050 -0.50 RE56400100 -1.00</p> <p>1,750 (500) CrB Fe S IF 2,000 (508) P 3,000 (604) Cr P</p>	<p>ø26,0 x 66,0</p>	<p>G84001580K_1</p> <p>A= 84,000 B= 80,300 D= 85,000 F= 5,000 H= 0,000 L= 158,000</p> 		
<p>ø81,00</p> <p>4 Cyl. Diesel 1968 cc 100 103 KW/136 140 PS BGW BMM BMP BRT BSS <u>2003 -....</u></p> <p><i>3. & 4. Sil. Caddy III BOX 2.0 TDI Golf VI 2.0 TDI Jetta III 2.0 TDI 2003 -</i></p>	<p>17-7094780 STD 17-7094783 0.50</p>	<p>A = 45,800 B = 68,800 C = 17,500 E = -0,700 CD= 38,000</p> <p>Segman Taşıyıcı (Ring Carrier)</p> <p>Yag Galerisi (Oil Gallery)</p> <p>Yag Püskürt. Oyugu (Oil Cut-Out)</p> <p>Burc (Bushing)</p>	<p>RE56400000 -STD RE56400025 -0.25 RE56400050 -0.50 RE56400100 -1.00</p> <p>1,750 (500) CrB Fe S IF 2,000 (508) P 3,000 (604) Cr P</p>	<p>ø26,0 x 66,0</p>	<p>G84001580K_1</p> <p>A= 84,000 B= 80,300 D= 85,000 F= 5,000 H= 0,000 L= 158,000</p> 		



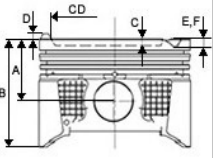





							
Motor /Engine	Ref. No. Kit 1	Ölçüler /Dimensions	Segman /Rings	Pim	Gömlek /Liner	Kit 2	Info
<p>ø81,01</p> <p>4 Cyl. Diesel 1968 cc 69 Ps BDJ BDK BST <u>2004 -....</u> 1. & 2. Sil. Caddy 2.0 SDI</p>	<p>18-7050780 STD 18-7050783 0.50</p>	<p>A = 37,800 B = 58,800 C = 17,350 E = -0,700 CD= 38,000</p> <p>Segman Taşıyıcı (Ring Carrier)</p>	<p>RE56400000 -STD RE56400025 -0.25 RE56400050 -0.50 RE56400100 -1.00</p> <p>1,750 (500) CrB Fe S IF 2,000 (508) P 3,000 (604) Cr P</p>	<p>ø22,0 x 60,0</p>			<p>1.Çentik conta +0,91 +1,00</p> <p>2.Çentik conta +1,01 +1,10</p> <p>3.Çentik conta +1,11 +1,20</p>
<p>ø81,01</p> <p>4 Cyl. Diesel 1968 cc 69 Ps BDJ BDK BST <u>2004 -....</u> 3. & 4. Sil. Caddy 2.0 SDI</p>	<p>18-7050790 STD 18-7050793 0.50</p>	<p>A = 37,800 B = 58,800 C = 17,350 E = -0,700 CD= 38,000</p> <p>Segman Taşıyıcı (Ring Carrier)</p>	<p>RE56400000 -STD RE56400025 -0.25 RE56400050 -0.50 RE56400100 -1.00</p> <p>1,750 (500) CrB Fe S IF 2,000 (508) P 3,000 (604) Cr P</p>	<p>ø22,0 x 60,0</p>			<p>1.Çentik conta +0,91 +1,00</p> <p>2.Çentik conta +1,01 +1,10</p> <p>3.Çentik conta +1,11 +1,20</p>



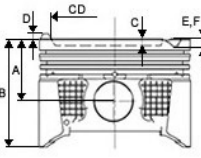





Motor /Engine	Ref. No. Kit 1	Ölçüler /Dimensions	Segman /Rings	Pim	Gömlek /Liner	Kit 2	Info
							
ø81,01 5 Cyl. Diesel 2461 cc 80 Kw (109 Ps) 19.5: AVR BBR <u>2004 -....</u> A6 2.5TDI	17-7071770 STD 17-7071773 0.50	A = 45,800 B = 69,800 C = 16,800 E = -1,350 CD= 46,000 Segman Taşıyıcı (Ring Carrier) Yag Püskürt. Oyugu (Oil Cut-Out) Burc (Bushing)	RE56410000 -STD RE56410050 -0.50 RE56410100 -1.00 2,500 (500) Cr P 2,000 (501) P 3,000 (604) Cr P	ø26,0 x 68,0			0 +0,75 1 kertik conta +0,87 +0,96 2 kertik conta +0,97 +1,01 3 kertik conta +1,02 +1,10
ø81,01 5 Cyl. Diesel 2460 cc 96/128 Kw (130 Ps) 1.ve 2.Sil.AXD AXE BLJ Euro 3 BNZ <u>2004 -....</u> 1. & 2. Sil. Transporter T5	17-7092820 STD 17-7092823 0.50	A = 45,750 B = 69,750 C = 18,200 E = -1,400 CD= 37,800 Segman Taşıyıcı (Ring Carrier) Yag Galerisi (Oil Gallery) Yag Püskürt. Oyugu (Oil Cut-Out) Burc (Bushing)	RE56410000 -STD RE56410050 -0.50 RE56410100 -1.00 2,500 (500) Cr P 2,000 (501) P 3,000 (604) Cr P	ø26,0 x 66,0			1 kertik conta +0,80 +0,90 2 kertik conta +0,90 +1,00 3 kertik conta +1,00 +1,10

Motor /Engine	Ref. No. Kit 1	Ölçüler /Dimensions	Segman /Rings	Pim	Gömlek /Liner	Kit 2	Info
       							
ø81,01 5 Cyl. Diesel 2460 cc 96/128 Kw (130 Ps) 3.4.&5.Sil.AXD AXE BLJ Euro 3 BNZ <u>2004 -....</u> 3.4. & 5. Sil. Transporter T5	17-7092830 STD 17-7092833 0.50	A = 45,750 B = 69,750 C = 18,200 E = -1,400 CD= 37,800 Segman Taşıyıcı (Ring Carrier) Yag Galerisi (Oil Gallery) Yag Püskürt. Oyugu (Oil Cut-Out) Burc (Bushing)	RE56410000 -STD RE56410050 -0.50 RE56410100 -1.00 2,500 (500) Cr P 2,000 (501) P 3,000 (604) Cr P	ø26,0 x 66,0			1 kertik conta +0,80 +0,90 2 kertik conta +0,90 +1,00 3 kertik conta +1,00 +1,10
ø81,01 4 Cyl. Diesel 2000 cc 140 Ps BKP BVE BMA BMN BMR BUZ BWV <u>2005 -....</u> Passat 2.0 TDI Jetta 2.0 TDI Golf V 2.0 TDI	18-7092840 STD 18-7092843 0.50	A = 45,800 B = 68,800 C = 17,800 CD= 38,000 Segman Taşıyıcı (Ring Carrier) Yag Galerisi (Oil Gallery) Yag Püskürt. Oyugu (Oil Cut-Out) Burc (Bushing)	RE56400000 -STD RE56400025 -0.25 RE56400050 -0.50 RE56400100 -1.00 1,750 (500) CrB Fe S IF 2,000 (508) P 3,000 (604) Cr P	ø26,0 x 66,0			

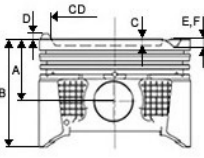





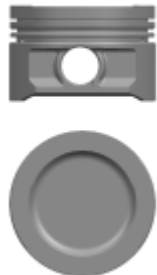
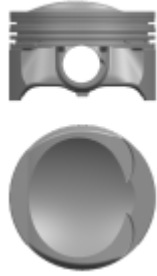

							
Motor /Engine	Ref. No. Kit 1	Ölçüler /Dimensions	Segman /Rings	Pim	Gömlek /Liner	Kit 2	Info
<p>ø81,01</p> <p>5 Cyl. Diesel 2459cc 100 Kw (136 Ps) BJM CECB BJL Euro4 BJM Euro4 CECA Euro5 <u>2006 -....</u></p> <p>LT 28 LT 35 LT 46 Crofter-LT 28 D LT 35 D LT 46 D</p>	<p>17-7092850 STD 17-7092853 0.50</p>	<p>A = 45,750 B = 69,750 C = 16,600 E = -1,350 CD= 45,900</p> <p>Segman Taşıyıcı (Ring Carrier)</p> <p>Yag Galerisi (Oil Gallery)</p> <p>Yag Püskürt. Oyugu (Oil Cut-Out)</p> <p>Burc (Bushing)</p>	<p>RE56410000 -STD RE56410050 -0.50 RE56410100 -1.00</p> <p>2,500 (500) Cr P 2,000 (501) P 3,000 (604) Cr P</p>	<p>ø26,0 x 66,0</p>			
<p>ø81,01</p> <p>4 Cyl. Diesel 1968 cc 110 KW (150 PS) CXHA DAUB DAWA DASA <u>2015 -</u></p> <p>TRANSPORTER MULTIVAN 2.0 TDI</p>	<p>18-7094340 STD 18-7094343 0.50</p>	<p>A = 45,800 B = 68,800 C = 13,300 CD= 50,880</p> <p>Segman Taşıyıcı (Ring Carrier)</p> <p>Yag Galerisi (Oil Gallery)</p> <p>Burc (Bushing)</p>	<p>RK56281010010 -STD RK56281010013 -0.50</p> <p>1,750 () Cr 2,000 () IF 2,000 ()</p>	<p>ø26,0 x 66,0</p>			

Motor /Engine	Ref. No. Kit 1	Ölçüler /Dimensions	Segman /Rings	Pim	Gömlek /Liner	Kit 2	Info
							
ø81,01 4 Cyl. Diesel 1968 cc 88/90/100/103 105/120/125 KW 84/110/114/120/136 140/143/163/170 PS 16,5:1 CJAA CFHB CFHC CFHE CFJA CAGA/B/C CAHA/B CBAA/BB CAAA/B/C/D/E CBDA/B/C <u>2005 -....</u> Golf VI 2.0TDI Jetta IV 2.0TDI Caddy III 2.0TDI Touran 2.0TDI 2005 -	18-7094490 STD 18-7094493 0.50	A = 45,800 B = 68,800 C = 12,700 CD= 50,880 Segman Taşıyıcı (Ring Carrier) Yag Galerisi (Oil Gallery) Yag Püskürt. Oyugu (Oil Cut-Out) Burc (Bushing)	RE56400000 -STD RE56400025 -0.25 RE56400050 -0.50 RE56400100 -1.00 1,750 (500) CrB Fe S IF 2,000 (508) P 3,000 (604) Cr P	ø26,0 x 66,0			
ø81,01 4 Cyl. Diesel 1968 cc 89 120KW/121 170 HP BKD BLB BNA BMN <u>2003 -....</u> GOLF V 2.0 TDI JETTA III 2.0 TDI TOURAN 2.0 TDI 2003 -	18-7094670 STD 18-7094673 0.50	A = 48,800 B = 69,800 C = 17,800 CD= 38,000 Segman Taşıyıcı (Ring Carrier) Yag Galerisi (Oil Gallery) Yag Püskürt. Oyugu (Oil Cut-Out) Burc (Bushing)	RE56400000 -STD RE56400025 -0.25 RE56400050 -0.50 RE56400100 -1.00 1,750 (500) CrB Fe S IF 2,000 (508) P 3,000 (604) Cr P	ø26,0 x 66,0			

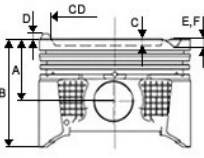





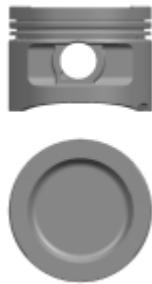
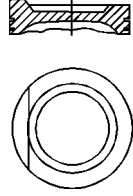

							
Motor /Engine	Ref. No. Kit 1	Ölçüler /Dimensions	Segman /Rings	Pim	Gömlek /Liner	Kit 2	Info
<p>ø82,50</p> <p>4 Cyl. Benzin 1984 cc 110/118/125/147 132/155/165 KW 150/160/170/200 204/211/225 PS GÜÇLENDİRİLMİŞ CAWB CCZA/B/D CAEA/B/D CBFA CCTA CFPA/KA CJKA/B CESA CETA MPMA/B CAWA/B</p> <p><u>2007 - ...</u> VW GOLF V-VII JETTA III SCIROCCO A...</p>	<p>18-7010290 STD 18-7010293 0.50</p>	<p>A = 29,600 B = 50,100 C = 6,200 F = -3,800 CD= 50,250</p> <p>Segman Taşıyıcı (Ring Carrier)</p>	<p>RE56120000 -STD RE56120050 -0.50</p> <p>1,200 (500) NitB S IF 1,200 (508) P 2,000 (700) 2 (700)Nit S</p>	<p>ø23,0 x 51,0</p>			
<p>ø82,50</p> <p>4 Cyl. Diesel 1798 cc 125 KW (170 PS) CJEB EUROS CJED/EE/SA/SB EURO 6 CYGA DAJB DAJA</p> <p><u>2011 - 2015</u> A4 B8 (8K2) 1.8 TFSI</p>	<p>18-7010390 STD 18-7010393 0.50</p>	<p>A = 29,800 B = 55,980 C = 4,750 D = 5,680 E = -3,470</p> <p>Segman Taşıyıcı (Ring Carrier)</p>	<p>RE56120000 -STD RE56120050 -0.50</p> <p>1,200 (500) NitB S IF 1,200 (508) P 2,000 (700) 2 (700)Nit S</p>	<p>ø23,0 x 51,0</p>			

							
Motor /Engine	Ref. No. Kit 1	Ölçüler /Dimensions	Segman /Rings	Pim	Gömlek /Liner	Kit 2	Info
<p>ø82,50</p> <p>4 Cyl. Benzin 1781cc/1791cc 88/118/125kw 120/160170ps BZB BYT CABA CABB CABD</p> <p><u>2006 - 2008</u></p> <p>A3 1.8 TFSI 16V</p>	<p>18-7010400 STD 18-7010403 0.50</p>	<p>A = 29,800 B = 55,980 C = 6,000 D = 4,750 CD= 67,000</p> <p>Segman Taşıyıcı (Ring Carrier)</p>	<p>RE12160000 -STD RE12160025 -0.25 RE12160050 -0.50 RE12160100 -1.00</p> <p>1,200 (500) NiB S IF 1,500 (501) P 2,000 (700) CrPS</p>	<p>ø21,0 x 53,0</p>			
<p>ø82,50</p> <p>V 6 Benzin, 2597 cm³ 110 kW (150 hp), 10:1 ABC ACZ</p> <p><u>1994 - 1998</u></p> <p>Audi 80 2.6 Audi 100 2.6 Audi A4 2.6 Audi A6 2.6</p>	<p>17-7010410 STD 17-7010413 0.50</p>	<p>A = 33,500 B = 54,200 C = 3,000 D = 0,700 CD= 61,800</p>	<p>RE12140000 -STD RE12140050 -0.50</p> <p>1,500 (500) CrB Fe S IF 1,750 (508) P 3,000 (700) Cr P S</p>	<p>ø21,0 x 24,6</p>			

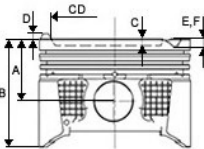











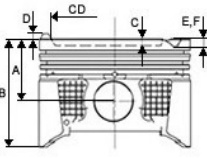





							
Motor /Engine	Ref. No. Kit 1	Ölçüler /Dimensions	Segman /Rings	Pim	Gömlek /Liner	Kit 2	Info
<p>ø82,50</p> <p>4 Cyl. Benzin 1984 cc 85 Kw (115 Ps) 10.4 AAD ABK</p> <p><u>1990 - 1994</u></p> <p>Audi 80 2.0 E Audi 100 2.0 E Audi A6 2.0 Cabriolet 2.0 I</p>	<p>18-7010420 STD 18-7010423 0.50</p>	<p>A = 30,900 B = 63,900 C = 5,000 D = 0,900 CD= 63,800</p> <p>Yag Püskürt. Oyugu (Oil Cut-Out)</p>	<p>RE12160000 -STD RE12160025 -0.25 RE12160050 -0.50 RE12160100 -1.00</p> <p>1,200 (500) NitB S IF 1,500 (501) P 2,000 (700) CrPS</p>	<p>ø21,0 x 61,0</p>			
<p>ø82,50</p> <p>6 Cyl. Benzin 2771 cc 128 Kw (174 Ps) AAH AFC AEJ</p> <p><u>1990 - 1997</u></p> <p>Audi 80 2.8 Audi 100 2.8 Audi A4 2.8 Audi A6 2.8 Audi A8 2.8</p>	<p>17-7010430 STD 17-7010433 0.50</p>	<p>A = 30,800 B = 52,500 C = 4,250 CD= 61,500</p>	<p>RE12160000 -STD RE12160025 -0.25 RE12160050 -0.50 RE12160100 -1.00</p> <p>1,200 (500) NitB S IF 1,500 (501) P 2,000 (700) CrPS</p>	<p>ø21,0 x 56,0</p>			



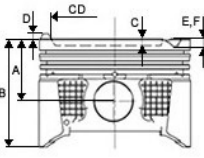





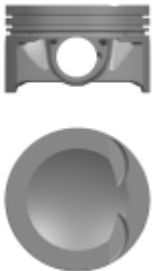



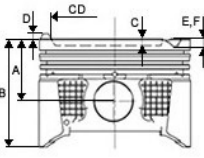





							
Motor /Engine	Ref. No. Kit 1	Ölçüler /Dimensions	Segman /Rings	Pim	Gömlek /Liner	Kit 2	Info
<p>ø82,50</p> <p>5 Cyl. Benzin, 2309 cm³ 98 kW (133 hp), 10:1 AAR NF NG <u>1990 - 1996</u></p> <p><i>Audi 80 2.3 E</i> <i>Audi 100 2.3 E</i> <i>Audi 2.3</i> <i>Audi A6 2.3</i></p>	<p>18-7010440 STD 18-7010443 0.50</p>	<p>A = 32,200 B = 54,300 C = 4,400 D = 1,100 CD= 60,000</p>	<p>RE12140000 -STD RE12140050 -0.50</p> <p>1,500 (500) CrB Fe S IF 1,750 (508) P 3,000 (700) Cr P S</p>	<p>ø20,0 x 68,0</p>			
<p>ø82,50</p> <p>4 Cyl. Benzin 1984 cc 96 KW 131 PS ALT <u>2000 -....</u></p> <p><i>Passat 2.0i 20V</i> <i>2000 -</i></p>	<p>18-7010480 STD 18-7010483 0.50</p>	<p>A = 29,600 B = 50,600 C = 2,600 CD= 64,000</p>	<p>RE12160000 -STD RE12160025 -0.25 RE12160050 -0.50 RE12160100 -1.00</p> <p>1,200 (500) NitB S IF 1,500 (501) P 2,000 (700) CrPS</p>	<p>ø19,0 x 44,0</p>			



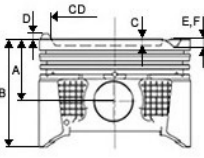





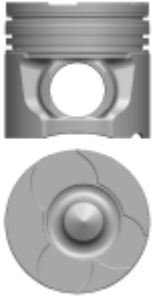

							
Motor /Engine	Ref. No. Kit 1	Ölçüler /Dimensions	Segman /Rings	Pim	Gömlek /Liner	Kit 2	Info
<p>ø82,50</p> <p>4 Cyl. Benzin 1798cc 88/112/118 KW (120/152/160 Ps) CDAA CDAB CDHA CDHB <u>2010 -....</u> Passat 1,8 FSI Golf VI</p>	<p>18-7050460 STD 18-7050463 0.50</p>	<p>A = 29,850 B = 50,350 C = 14,650 D = 5,650 E = -2,000</p> <p>Segman Taşıyıcı (Ring Carrier)</p>	<p>RE56390000 -STD RE56390050 -0.50</p> <p>1,200 () 1,200 () 2,000 ()</p>	<p>ø23,0 x 51,0</p>			
<p>ø82,50</p> <p>4 Cyl. Benzin 1984 cc 110 Kw (150 PS) BLR <u>2004 -....</u> Golf 2.0 FSI 16V Jetta 2.0 FSI 16V Passat 2.0 FSI 16V 2004-</p>	<p>18-7051470 STD 18-7051473 0.50</p>	<p>A = 29,400 B = 47,400 C = 7,360 D = 12,460 E = -1,980</p> <p>Sert Anotlama (Hard Anodising)</p>	<p>RE56370000 -STD RE56370050 -0.50 RE56370100 -1.00</p> <p>1,200 (500) NitB S IF 1,500 (508) P 2,000 (700) Nit S</p>	<p>ø19,0 x 44,0</p>			

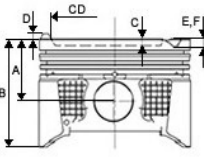





							
Motor /Engine	Ref. No. Kit 1	Ölçüler /Dimensions	Segman /Rings	Pim	Gömlek /Liner	Kit 2	Info
<p>ø82,51</p> <p>4 Cyl. Benzin 1984 cc 132/155/162/165 169/170/175 183/185 KW (180/211/220 224/230/231 238 249/252 CHHA/B CNCD/E CNTA/C CULC/B CVJA CWZA CYMC/NB/PA/PB/RB/RC DAXB/C DYVA DEDA CPLA/PA CXDA DCGA 2013 -</p> <p><i>GOLF VII (5G1-BQ1-BE1-BE2) 2.0 GTI</i></p>	<p>18-7010330 STD 18-7010333 0.50</p> 	<p>A = 29,600 B = 50,100 C = 6,200 E = -3,600 CD= 50,000</p> <p>Segman Taşıyıcı (Ring Carrier)</p>	<p>RE56120000 -STD RE56120050 -0.50</p> <p>1,200 (500) NitB S IF 1,200 (508) P 2,000 (700) 2 (700Nit S</p>	<p>ø23,0 x 51,0</p>			
<p>ø82,51</p> <p>4 Cyl. Diesel 1984 cc 169/195/200 206/210/213/215 221/228</p> <p>KW (265/272/280/286 290/292/300/310 PS) EURO 6 CJXB CJXC CJXD CJXF CJXG CYFB DJHA DJHB DJHC DJJA DLRA DKTA DNUA DNUE CJXA CJXE CJXH -</p> <p><i>EURO 6 CJXB-CJX-CJXD CJXF-CJXG-CYFB DJHA-DJHB-DJHC DJJA-DLRA-DKTA DNUA-DNUE-CJXA CJXE-CJXH</i></p>	<p>18-7010470 STD 18-7010473 0.50</p> 	<p>A = 29,600 B = 50,100 C = 6,200 E = -3,600 CD= 57,500</p> <p>Segman Taşıyıcı (Ring Carrier)</p>	<p>RE56120000 -STD RE56120050 -0.50</p> <p>1,200 (500) NitB S IF 1,200 (508) P 2,000 (700) 2 (700Nit S</p>	<p>ø23,0 x 51,0</p>			





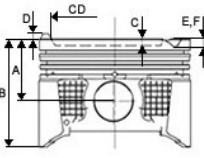
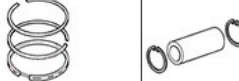



							
Motor /Engine	Ref. No. Kit 1	Ölçüler /Dimensions	Segman /Rings	Pim	Gömlek /Liner	Kit 2	Info
<p>ø82,51</p> <p>4 Cyl. Benzin 1984 cc 85 kW 115 PS</p> <p>BHP AZJ CBPA BER AZA R4</p> <p><u>1998 -</u></p> <p>BHP-AZI-CBPA BER-AZA-R4 BORA GOLF GOLFIV JETTA-TRANSPORTER T</p>	<p>18-7010490 STD 18-7010491 0.25 18-7010493 0.50</p>	<p>A = 30,000 B = 49,000 C = 5,700 E = -0,700 CD= 63,850</p> <p>Segman Taşıyıcı (Ring Carrier)</p>	<p>RE12160000 -STD RE12160025 -0.25 RE12160050 -0.50 RE12160100 -1.00</p> <p>1,200 (500) NitB S IF 1,500 (501) P 2,000 (700) CrPS</p>	<p>ø19,0 x 42,0</p>			
<p>ø83,00</p> <p>6 Cyl. Diesel 2967cc 211/235/245 Ps</p> <p>BUN BUG BKS BSG BKN</p> <p><u>2007 - 2015</u></p> <p>A6 3.0 TDI Q7 3.0 TDI 24V Touareg I 3.0 TDI 24V</p>	<p>17-7086880 STD 17-7086883 0.50</p>	<p>A = 46,300 B = 70,800 C = 15,100 CD= 45,000</p> <p>Segman Taşıyıcı (Ring Carrier)</p> <p>Yag Galerisi (Oil Gallery)</p>	<p>RE12280000 -STD RE12280050 -0.50</p> <p>2,000 (500) Cr P 2,000 (501) Cr IFU 3,000 (604) Cr P</p>	<p>ø30,0 x 68,0</p>			

							
Motor /Engine	Ref. No. Kit 1	Ölçüler /Dimensions	Segman /Rings	Pim	Gömlek /Liner	Kit 2	Info
<p>ø93,00</p> <p>4 Cyl. Diesel 2798 cc 116 Kw (158 Ps) BCQ AUH ATA AGK <u>2002 -....</u></p> <p>LT28 D LT35 D LT46 D</p>	<p>18-7086760 STD 18-7086763 0.50</p>	<p>A = 56,200 B = 86,200 C = 18,500 E = -1,500 CD= 47,100</p> <p>Segman Taşıyıcı (Ring Carrier)</p> <p>Sert Anotlama (Hard Anodising)</p> <p>Yag Püskürt. Oyugu (Oil Cut-Out)</p>	<p>RE56460000 -STD RE56460050 -0.50</p> <p>2,500 (504) Cr P 2,000 (501) P IWU 3,000 (604) Cr P</p>	<p>ø35,0 x 77,0</p>			
<p>ø93,00</p> <p>4 Cyl. Diesel 2792 cc 116 Kw (158 Ps) AUH BCQ <u>2003 -....</u></p> <p>LT28 D LT35 D LT46 D C.Rail</p>	<p>18-7086770 STD 18-7086773 0.50</p>	<p>A = 56,150 B = 82,200 C = 18,500 E = -1,500 CD= 47,100</p> <p>Segman Taşıyıcı (Ring Carrier)</p> <p>Sert Anotlama (Hard Anodising)</p> <p>Yag Püskürt. Oyugu (Oil Cut-Out)</p>	<p>RE56460000 -STD RE56460050 -0.50</p> <p>2,500 (504) Cr P 2,000 (501) P IWU 3,000 (604) Cr P</p>	<p>ø35,0 x 77,0</p>			

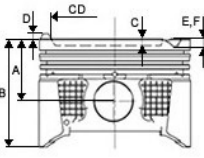





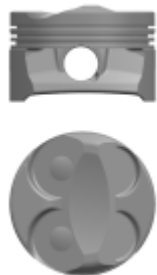

							
Motor /Engine	Ref. No. Kit 1	Ölçüler /Dimensions	Segman /Rings	Pim	Gömlek /Liner	Kit 2	Info
<p>ø77,00</p> <p>4 Cyl.Benzin 1598 cc 75/88/90/147 102/120/122/200 PS BMW N 13 B16A MINI N18 B 16A 5FU(EP6CDTX/EP6DTX) 5FW(EP6) <u>2010 -....</u></p> <p>BMW 116i MINI COOPER S 1.6i 16V PEUGEOT 77 MM</p>	<p>18-5510310 STD 18-5510310-30 STD 18-5510313 0.50 18-5510313-30 0.50</p>	<p>A = 28,500 B = 51,200 C = 3,500 D = 2,700 E = -3,300 F = -3,400 CD= 34,700</p> <p>Sert Anotlama (Hard Anodising)</p>	<p>RE15260000 -STD RE15260000_NPR -STD x 48,0 RE15260050 -0.50 RE15260050_NPR -0.50</p> <p>1,200 (500) Cr S IF 1,500 (508) P 2,000 (700) Cr P S</p>	<p>ø20,0 x 48,0</p>			
<p>ø77,00</p> <p>4 Cyl.Benzin 1598 cc EP6 EP6C <u>2010 -....</u></p> <p>3008 16i 16V 5008 1.6i 2 207 1.6 16V 308 1.6 16V</p>	<p>18-5510320 STD 18-5510323 0.50</p>	<p>A = 27,500 B = 47,500 C = 2,000 E = -5,700 F = -3,800 CD= 56,600</p>	<p>RE15260000 -STD RE15260000_NPR -STD x 43,0 RE15260050 -0.50 RE15260050_NPR -0.50</p> <p>1,200 (500) Cr S IF 1,500 (508) P 2,000 (700) Cr P S</p>	<p>ø18,0 x 43,0</p>			



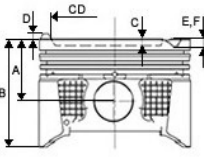









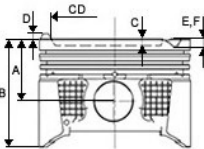





							
Motor /Engine	Ref. No. Kit 1	Ölçüler /Dimensions	Segman /Rings	Pim	Gömlek /Liner	Kit 2	Info
<p>ø77,00</p> <p>4 Cyl. Benzin 1598 cc (175PS) 115 156 PS 2010 ÖNCESİ EP6D1.6L R55 R56 R57 <u>2007-2010</u></p> <p>MINI COOPER 208 3008 308 508</p>	<p>18-5510330 STD 18-5510330-30 STD 18-5510333 0.50 18-5510333-30 0.50</p>	<p>A = 28,500 B = 51,200 C = 3,500 D = 2,700 E = -3,300 F = -3,400 CD= 34,700</p> <p>Sert Anotlama (Hard Anodising)</p>	<p>RE15260000 -STD RE15260000_NPR -STD x 48,0 RE15260050 -0.50 RE15260050_NPR -0.50</p> <p>1,200 (500) Cr S IF 1,500 (508) P 2,000 (700) Cr P S</p>	<p>ø20,0 x 48,0</p>			
<p>ø77,00</p> <p>4 Cyl. Benzin 1598 cc</p> <p>GÜÇLENDİRİLMİŞ S R53*/R52/JCW GP 1.6 I4 <u>2000 - 2008</u></p> <p>MINI COOPER S R53 CABRIO R52 MINI COOPER S JCW/CHALLENGE</p>	<p>18-5510360 STD 18-5510363 0.50</p>	<p>A = 26,300 B = 47,000 C = 0,600 CD= 56,500</p> <p>Segman Taşıyıcı (Ring Carrier)</p> <p>Sert Anotlama (Hard Anodising)</p>	<p>RE41010000 -STD RE41010000_AS -STD x 47,5 RE41010050 -0.50 RE41010050_AS -0.50</p> <p>1,200 (500) CrSIF 1,200 (508) P 2,500 (700) CrPS</p>	<p>ø21,0 x 47,5</p>			



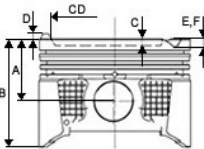





							
Motor /Engine	Ref. No. Kit 1	Ölçüler /Dimensions	Segman /Rings	Pim	Gömlek /Liner	Kit 2	Info
<p>ø77,00</p> <p>4 Cyl. Diesel 1598 cc 199/184/199KW 1.6 THP 16v 270 EP6CDTR BMW6EP6FADTR ADTR EU62V EP6FDTR</p> <p>.....-</p> <p>EP6FADTR ADTR EU62V EP6FDTR</p>	<p>18-5510390 STD 18-5510393 0.50</p>	<p>A = 28,500 B = 48,500 C = 3,000 E = -3,400 F = -3,400</p> <p>Sert Anotlama (Hard Anodising)</p>	<p>RE15260000 -STD RE15260000_NPR -STD x 48,0 RE15260050 -0.50 RE15260050_NPR -0.50</p> <p>1,200 (500) Cr S IF 1,500 (508) P 2,000 (700) Cr P S</p>	<p>ø20,0</p>			
<p>ø77,00</p> <p>4 Cyl. Benzin 1397 cc 50/70 kW 75/95 PS EP3 N12B14A</p> <p>.....-</p> <p>207 WA/WC 1.4 16V 207 SW (WK) 1.4 16V 308 4A/4C 1.4 16V</p>	<p>18-7510280 STD 18-7510283 0.50</p>	<p>A = 27,600 B = 47,500 D = 3,100</p>	<p>RE15260000 -STD RE15260000_NPR -STD x 43,0 RE15260050 -0.50 RE15260050_NPR -0.50</p> <p>1,200 (500) Cr S IF 1,500 (508) P 2,000 (700) Cr P S</p>	<p>ø18,0</p>			



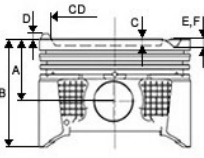









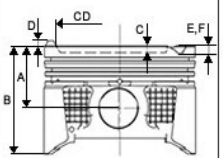





							
Motor /Engine	Ref. No. Kit 1	Ölçüler /Dimensions	Segman /Rings	Pim	Gömlek /Liner	Kit 2	Info
<p>ø78,00</p> <p>4 Cyl. Diesel 1568 cc 70/66/85 KW 90/95/116 HP N47 D16A/N N47C16A <u>2012 -....</u></p> <p>114d 116d Cooper 1.6D Cooper One 1.6D Countryman</p>	<p>18-5592100 STD 18-5592103 0.50</p>	<p>A = 40,000 B = 62,500 C = 13,350 CD= 47,100</p> <p>Segman Taşıyıcı (Ring Carrier)</p> <p>Yag Galerisi (Oil Gallery)</p> <p>Sac Plaka (Steel Support)</p>	<p>RE15480000 -STD RE15480050 -0.50</p> <p>1,750 (500) Cr P IF 1,750 (501) P IFU 2,000 (604) Nit S</p>	<p>ø26,0 x 56,0</p>			
<p>ø80,00</p> <p>6 Cyl. Benzin 1991 cc 110 Kw (150 Ps) M50 B20 6 Sil. Benzinli 1991 cc 110 Kw (150 Ps) 1 <u>1992 - 1995</u></p> <p>BMW 320i Coupe 320i 520i 520i Touring 1992/1995</p>	<p>17-5510210 STD 17-5510213 0.50 17-5510218 1.00</p>	<p>A = 33,500 B = 51,000 D = 1,860 E = -2,940</p> <p>Sac Plaka (Steel Support)</p>	<p>RE15150000 -STD RE15150050 -0.50 RE15150100 -1.00</p> <p>1,500 (500) Cr S IF 1,500 (508) P 2,000 (700) Nit S</p>	<p>ø22,0 x 51,0</p>			

							
Motor /Engine	Ref. No. Kit 1	Ölçüler /Dimensions	Segman /Rings	Pim	Gömlek /Liner	Kit 2	Info
<p>ø80,00</p> <p>6 Cyl. Benzin 110 Kw (150 Ps) 10,5:1 M50 B20M <u>1990 -....</u> BMW 320i 520i 1990 -</p>	<p>17-5510220 STD 17-5510223 0.50 17-5510228 1.00</p>	<p>A = 42,400 B = 62,400 E = -1,310 F = -3,130</p> <p>Sac Plaka (Steel Support)</p>	<p>RE15150000 -STD RE15150050 -0.50 RE15150100 -1.00</p> <p>1,500 (500) Cr S IF 1,500 (508) P 2,000 (700) Nit S</p>	<p>ø22,0 x 54,0</p>			
<p>ø80,00</p> <p>6 Cyl. Benzin 1990 cc 92 Kw (125 Ps) 9,8: M20 3.20i 5.20 i24V 150PS V6 <u>1981 - 1988</u> BMW 320i 520i 1981/1988</p>	<p>17-5510230 STD 17-5510233 0.50</p>	<p>A = 43,400 B = 71,700 D = 3,300 E = -1,300</p> <p>Sac Plaka (Steel Support)</p>	<p>RE15280000 -STD RE15280050 -0.50 RE15280100 -1.00</p> <p>1,500 (500) Cr S IF 2,000 (508) P 3,500 (700) Cr P S</p>	<p>ø22,0 x 61,0</p>			

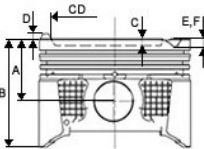







							
Motor /Engine	Ref. No. Kit 1	Ölçüler /Dimensions	Segman /Rings	Pim	Gömlek /Liner	Kit 2	Info
<p>ø80,00</p> <p>6 Cyl. Benzin 1991 cc 110 Kw (150 Ps) 9,8:1 M52 B20</p> <p><u>1993 -....</u></p> <p>BMW 320i (E36) 520i Z3 1993</p>	<p>17-5510240 STD 17-5510243 0.50</p>	<p>A = 32,200 B = 54,600 D = 1,400 E = -1,500 F = -2,800</p>	<p>RE15150000 -STD RE15150050 -0.50 RE15150100 -1.00</p> <p>1,500 (500) Cr S IF 1,500 (508) P 2,000 (700) Nit S</p>	<p>ø22,0 x 51,0</p>			
<p>ø80,00</p> <p>6 Cyl. Benzin 2171cc 141 KW / 170 PS M54B22 6 Sil. Benzinli 2171cc 141 KW 70 PS 10.8:1</p> <p><u>2000 - 2006</u></p> <p>BMW 320i 2.2 24V (E46) 520i 2.2 24V (E39) 520i 2.2 24V (E60)</p>	<p>17-5510400 STD 17-5510403 0.50</p>	<p>A = 29,600 B = 49,500 E = -2,900 F = -3,400</p>	<p>RE15360000 -STD RE15360050 -0.50</p> <p>1,200 (500) Nit S 1,500 (508) P 2,000 (700) Nit S</p>	<p>ø22,0 x 51,0</p>			



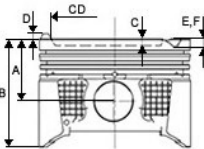





							
Motor /Engine	Ref. No. Kit 1	Ölçüler /Dimensions	Segman /Rings	Pim	Gömlek /Liner	Kit 2	Info
<p>ø80,00</p> <p>6 Cyl. Benzin, 1991 cm³ 110 kW (150 hp) M52 B(20 6 S3) Vanos M52 B(20 6 S4)</p> <p><u>1993 -....</u></p> <p>BMW 320 Ci 320 i 520 i Z3 2.0 1999-2003</p>	<p>17-5510420 STD 17-5510423 0.50 17-5510428 1.00</p>	<p>A = 31,700 B = 51,300 D = 2,100 E = -3,000</p> <p>Sac Plaka (Steel Support)</p>	<p>RE15150000 -STD RE15150050 -0.50 RE15150100 -1.00</p> <p>1,500 (500) Cr S IF 1,500 (508) P 2,000 (700) Nit S</p>	<p>ø22,0 x 51,0</p>			
<p>ø80,00</p> <p>4/6 Cyl. Diesel 1669/2498 cc 105 Kw (90/143 Ps) M41/M51 D25WA/BMW 25 6T X 25 DT/TD 25 LT</p> <p><u>1990 -....</u></p> <p>Turbo Intercooler 318 Compact TDS/TouringSE 325 325/525 TDS/Touring 725 TDS Omega TDS Range Rover</p>	<p>17-6592090 STD 17-6592093 0.50</p>	<p>A = 39,450 B = 62,450 C = 2,500</p> <p>Segman Taşıyıcı (Ring Carrier)</p> <p>Yag Galerisi (Oil Gallery)</p> <p>Sac Plaka (Steel Support)</p> <p>Yag Püskürt. Oyugu (Oil Cut-Out)</p>	<p>RE15140000 -STD RE15140050 -0.50 RE15140100 -1.00</p> <p>3,000 (504) Cr 1,750 (501) P IFU 3,000 (604) Cr</p>	<p>ø27,0 x 63,0</p>			

Motor /Engine	Ref. No. Kit 1	Ölçüler /Dimensions	Segman /Rings	Pim	Gömlek /Liner	Kit 2	Info	
       								
ø82,00 3 Cyl. Benzin 1499 cc 55/75/80/100 115/120/125 141/170 KW 75/102/109/136 156/163/170 192/231 PS GÜÇLENDİRİLMİŞ B38 A15/B15/K15 A B32 S15 A B42 S20 A B36/46 A15A B48 A20 A/B B 48 B16/20 A/B BRIL. ----- F20 116/118i F21 116/118i F40 116/118i Active Tourer (F45) 216/218i-225 Plug Cabrio (F23) 218i Coupe (F22/23/87)218i Gran Tourer (F46) 216/218i Gran Coupe (F44) 218i (F30/80) 318i Touring (F3	17-5510110 STD 17-5510110-30 STD 17-5510113 0.50 17-5510113-30 0.50	A = 33,200 B = 51,000 C = 2,150 E = -4,900 F = -5,300 CD= 62,100 Segman Taşıyıcı (Ring Carrier)	RE15360000 -STD RE15360050 -0.50 1,200 (500) Nit S 1,500 (508) P 2,000 (700) Nit S	ø22,0 x 55,0				
ø82,00 3/4 Cyl. Benzin 1499/1597/1998 cc 100/115/120/125 135/150/170/185 200/215kW 109..292HP B38 A15 A/C B48 A20 A/C B48 B16/20 A ZINOPRO B38 A15 C xDrive sDrive Mild/E Plug in Hybrid <u>2015 - 2021</u> F20/F21/F23/F33/F83 F22/F87/F32/F82/F36 F90/F97/F98 G20/G80/G28/G21/G81 G01/G02/G22/G31 Cabrio Coupe Touring/Van Gran Coupe/X3/X4	17-5510300 STD 17-5510303 0.50	A = 33,300 B = 52,700 C = 2,000 E = -4,800 F = -5,100 CD= 56,000 Sert Anotlama (Hard Anodising)	RE15360000 -STD RE15360050 -0.50 1,200 (500) Nit S 1,500 (508) P 2,000 (700) Nit S	ø21,0 x 51,0				

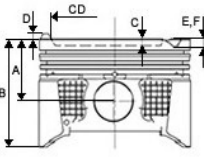





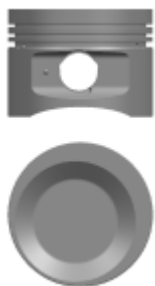

							
Motor /Engine	Ref. No. Kit 1	Ölçüler /Dimensions	Segman /Rings	Pim	Gömlek /Liner	Kit 2	Info
<p>ø84,00</p> <p>6 Cyl. Benzin 2791 cc 141 Kw (191 Ps) M52B 28GG <u>1995 - 1998</u></p> <p><i>BMW 328i 528i 728i 1995/1998</i></p>	<p>17-5510250 STD 17-5510253 0.50</p>	<p>A = 31,820 B = 51,820 E = -1,550 F = -1,700</p>	<p>RE15170000 -STD RE15170050 -0.50 RE15170100 -1.00</p> <p>1,500 (500) Cr S IF 1,500 (508) P 2,000 (700) Nit S</p>	<p>ø22,0 x 56,0</p>			
<p>ø84,00</p> <p>4 Cyl. Benzin 1573 cc 66 Kw (90 Ps) 8,3:1 M10B 16E21. 4 Sil. Benzinli 1573 cc 66 Kw (90 Ps) <u>1975 - 1980</u></p> <p><i>BMW 316</i></p>	<p>18-5510260 STD 18-5510263 0.50</p>	<p>A = 46,700 B = 84,700 D = 6,000</p> <p>Sac Plaka (Steel Support)</p>	<p>RE15050000 -STD RE15050050 -0.50</p> <p>1,750 (500) Cr S IF 2,000 (508) P 4,000 (603) Fe</p>	<p>ø22,0 x 69,0</p>			



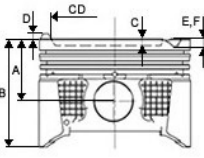









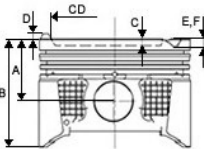



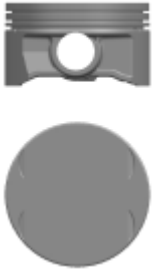

							
Motor /Engine	Ref. No. Kit 1	Ölçüler /Dimensions	Segman /Rings	Pim	Gömlek /Liner	Kit 2	Info
<p>ø84,00</p> <p>4 Cyl. Benzin 1596 cc 73 Kw (100 Ps) M40B 16ME <u>1988 - 1992</u> BMW Injection 316i</p>	<p>18-5510270 STD 18-5510273 0.50</p>	<p>A = 41,150 B = 67,150 C = 2,750 CD= 69,000</p> <p>Sac Plaka (Steel Support)</p>	<p>RE15030000 -STD RE15030050 -0.50</p> <p>1,500 (500) Cr S IF 1,750 (508) P 3,000 (700) Cr P S</p>	<p>ø22,0 x 54,3</p>			
<p>ø84,00</p> <p>4 Cyl. Benzin 1574 cc 55 Kw (75 Ps) M10B 16V. 4 Sil. Benzinli 1574 cc 55 Kw (75 Ps) 9. <u>1981 - 1983</u> BMW 316 1981 - 1983</p>	<p>18-5510280 STD 18-5510283 0.50</p>	<p>A = 47,100 B = 86,300 D = 7,200</p> <p>Sac Plaka (Steel Support)</p>	<p>RE15050000 -STD RE15050050 -0.50</p> <p>1,750 (500) Cr S IF 2,000 (508) P 4,000 (603) Fe</p>	<p>ø22,0 x 69,0</p>			



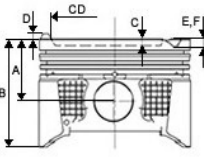





							
Motor /Engine	Ref. No. Kit 1	Ölçüler /Dimensions	Segman /Rings	Pim	Gömlek /Liner	Kit 2	Info
<p>ø84,00</p> <p>4 Cyl. Benzin 1795 cc 83 Kw (113 Ps) M40B 18E. 4 Sil. Benzinli 1795 cc 83 Kw (113 Ps) 8 <u>1991 - 1993</u></p> <p><i>BMW 318i 518i 1991/1993</i></p>	<p>18-5510290 STD 18-5510293 0.50</p>	<p>A = 31,650 B = 57,650 C = 5,330 CD= 73,000</p> <p>Sac Plaka (Steel Support)</p>	<p>RE15170000 -STD RE15170050 -0.50 RE15170100 -1.00</p> <p>1,500 (500) Cr S IF 1,500 (508) P 2,000 (700) Nit S</p>	<p>ø22,0 x 52,0</p>			
<p>ø84,00</p> <p>4 Cyl. Benzin 1795 cc 83 Kw (113 Ps) M40B 18E. 4 Sil. Benzinli 1795 cc 83 Kw (113 Ps) 8 <u>1987 - 1990</u></p> <p><i>BMW 318i (E30) 1987 - 1990</i></p>	<p>18-5510350 STD 18-5510353 0.50</p>	<p>A = 36,650 B = 62,650 C = 6,050 CD= 70,000</p> <p>Sac Plaka (Steel Support)</p>	<p>RE15030000 -STD RE15030050 -0.50</p> <p>1,500 (500) Cr S IF 1,750 (508) P 3,000 (700) Cr P S</p>	<p>ø22,0 x 54,0</p>			



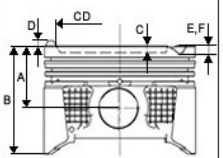







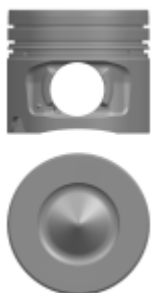

							
Motor /Engine	Ref. No. Kit 1	Ölçüler /Dimensions	Segman /Rings	Pim	Gömlek /Liner	Kit 2	Info
<p>ø84,00</p> <p>4 Cyl. Benzin 1796cc 85 Kw (116 PS) N42 B18 N42 B20 N45 B16 N46 B20 <u>2001 - 2004</u></p> <p>BMW 316 1.8i 16V (E46) 318 2.0i 16V (E46) 116 1.6i 16V (E87) 316 1.6i 16V</p>	<p>18-5510410 STD 18-5510413 0.50</p>	<p>A = 29,800 B = 50,800 E = -5,200 F = -5,200</p>	<p>RE15380000 -STD RE15380050 -0.50</p> <p>1,200 (500) Nit S IF 1,500 (508) P 2,000 (700) Nit S</p>	<p>ø20,0 x 50,0</p>			
<p>ø84,00</p> <p>6 Cyl. Benzin 2500 cc 125 170 Kw (170 231 PS) M54 B25 E39 E46. 6 Sil. Benzinli 2500 cc 125 170 <u>2000 - 2007</u></p> <p>BMW 325i 525i X3 Z4 X5 Z3 2000 - 2007</p>	<p>17-5510540 STD 17-5510543 0.50</p>	<p>A = 27,600 B = 47,600 E = -2,600</p>	<p>RE15380000 -STD RE15380050 -0.50</p> <p>1,200 (500) Nit S IF 1,500 (508) P 2,000 (700) Nit S</p>	<p>ø22,0 x 56,0</p>			

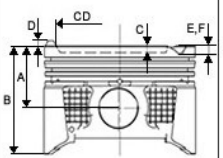







							
Motor /Engine	Ref. No. Kit 1	Ölçüler /Dimensions	Segman /Rings	Pim	Gömlek /Liner	Kit 2	Info
<p>ø84,00</p> <p>6 Cyl. Benzin 2979 cc 170 Kw (231 Ps) M54 B30. 6 Sil. Benzinli 2979 cc 170 Kw (231 Ps). <u>2000 - 2006</u></p> <p><i>BMW 330 i 530i 730 i X3 X5 Z3 Z4 2000 - 2006</i></p> 	<p>17-5510550 STD 17-5510553 0.50</p>	<p>A = 28,320 B = 48,320 E = -0,710</p>	<p>RE15380000 -STD RE15380050 -0.50</p> <p>1,200 (500) Nit S IF 1,500 (508) P 2,000 (700) Nit S</p>	<p>ø22,0 x 56,0</p>			
<p>ø84,00</p> <p>4 Cyl. Benzin 1796 cc 85 Kw (115 Ps) 9,7 1Injection,Catal.Conv M43B 18E36 <u>1993</u></p> <p><i>318g 518g 318i 518i Z3</i></p>	<p>18-5511310 STD 18-5511313 0.50</p>	<p>A = 31,650 B = 57,650 C = 3,030 CD= 70,300</p>	<p>RE15170000 -STD RE15170050 -0.50 RE15170100 -1.00</p> <p>1,500 (500) Cr S IF 1,500 (508) P 2,000 (700) Nit S</p>	<p>ø22,0 x 54,0</p>			



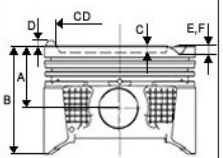





							
Motor /Engine	Ref. No. Kit 1	Ölçüler /Dimensions	Segman /Rings	Pim	Gömlek /Liner	Kit 2	Info
<p>ø84,00</p> <p>4 Cyl. Benzin 1795 cc 85 Kw (115 Ps) 8,8:1Injection, Catal.Conv M40B 18ME</p> <p><u>1987 - 1990</u></p> <p>318i</p>	<p>18-5511320 STD</p> <p>18-5511323 0.50</p>	<p>A = 31,150</p> <p>B = 56,150</p> <p>C = 1,190</p> <p>CD= 70,000</p> <p>Sac Plaka (Steel Support)</p>	<p>RE15170000 -STD</p> <p>RE15170050 -0.50</p> <p>RE15170100 -1.00</p> <p>1,500 (500) Cr S IF</p> <p>1,500 (508) P</p> <p>2,000 (700) Nit S</p>	<p>ø22,0</p> <p>x 54,0</p>			
<p>ø84,00</p> <p>4 Cyl. Diesel 1951 cc 100 Kw (136 Ps) M47D20.</p> <p>4 Sil. Dizel 1951 cc 100 Kw (136 Ps) 19:1.</p> <p><u>1998 -....</u></p> <p>BMW 320 D 520 D 1998 -....</p>	<p>18-5592110 STD</p> <p>18-5592113 0.50</p>	<p>A = 47,000</p> <p>B = 71,000</p> <p>C = 15,000</p> <p>E = -1,360</p> <p>F = -1,480</p> <p>CD= 41,700</p> <p>Segman Taşıyıcı (Ring Carrier)</p> <p>Yag Galerisi (Oil Gallery)</p> <p>Yag Püskürt. Oyugu (Oil Cut-Out)</p>	<p>RE15410000 -STD</p> <p>RE15410050 -0.50</p> <p>3,000 (504) Cr</p> <p>2,000 (508) P</p> <p>3,000 (604) Cr P</p>	<p>ø30,0</p> <p>x 68,0</p>			<p>1. Kertik conta + 0,80 / + 0,92</p> <p>2. Kertik conta + 0,93 / + 1,03</p>

Motor /Engine	Ref. No. Kit 1	Ölçüler /Dimensions	Segman /Rings	Pim	Gömlek /Liner	Kit 2	Info
							
ø84,00 4 Cyl. Diesel 2000 cc M47N. 4 Sil. Dizel 2000 cc. 2001 -.... BMW F-87 118D E-90 318D E-91 318D 2001 -	18-5592130 STD 18-5592133 0.50	A = 39,450 B = 62,450 C = 2,500 Segman Taşıyıcı (Ring Carrier) Yag Galerisi (Oil Gallery) Sac Plaka (Steel Support) Yag Püskürt. Oyugu (Oil Cut-Out)	RE15460000 -STD RE15460050 -0.50 3,000 (504) Cr P 2,000 (508) P 2,000 (604) Nit S	ø30,0 x 68,0			
ø84,00 4 Cyl. Diesel 1995 cc 85/130 Kw (115/177 HP) N47D EURO 4. 4 Sil. 1995 cc Dizel 85 130 Kw (115 2004 - 2011 BMW N47D EURO 4 116d 118d 120d 318d 320d 520d X3 Z 0d 2004 - 2011	18-5592140 STD 18-5592143 0.50	A = 47,000 B = 73,000 C = 15,250 CD= 47,500 Segman Taşıyıcı (Ring Carrier) Yag Galerisi (Oil Gallery) Yag Püskürt. Oyugu (Oil Cut-Out)	RE15440000 -STD RE15440050 -0.50 1,750 (500) Cr P 1,750 (508) P 2,000 (604) Nit S	ø32,0 x 64,0			1. Kertik conta + 0,80 + 0,92 2. Kertik conta + 0,93 + 1,03 3. Kertik conta + 1,04 + 1,20

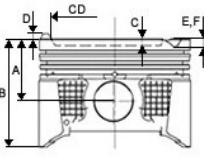







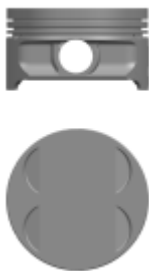



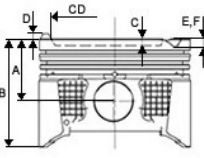





Motor /Engine	Ref. No. Kit 1	Ölçüler /Dimensions	Segman /Rings	Pim	Gömlek /Liner	Kit 2	Info
							
ø84,00 4/6 Cyl. Diesel 1995cc 135 kw 181HP N47TUN/B20 57 B30 N57D30A N57 D30 C <u>2013 -....</u> 318d 320d 520d 525 2013....	18-5592160 STD 18-5592161 0.25 18-5592163 0.50	A = 47,000 B = 73,000 C = 14,500 CD= 47,500 Segman Taşıyıcı (Ring Carrier) Yag Galerisi (Oil Gallery)	RE15440000 -STD RE15440050 -0.50 1,750 (500) Cr P 1,750 (508) P 2,000 (604) Nit S	ø32,0 x 64,0			
 							
ø84,00 4 Cyl. Diesel 2000 cc M47N. 4 Sil. Dizel 2000 cc. <u>2001 -....</u> BMW 320 D 320 TD E-46 320 CD 2001 -	18-5594110 STD 18-5594113 0.50	A = 44,870 B = 70,620 C = 13,500 E = -1,360 F = -1,480 CD= 46,900 Segman Taşıyıcı (Ring Carrier) Yag Galerisi (Oil Gallery) Yag Püskürt. Oyugu (Oil Cut-Out) Burc (Bushing)	RE15410000 -STD RE15410050 -0.50 3,000 (504) Cr 2,000 (508) P 3,000 (604) Cr P	ø30,0 x 68,0			1. Kertik conta + 0,85 + 0,90 2. Kertik conta + 0,90 + 1,00 3. Kertik conta + 1,00 / + 1,10

Motor /Engine	Ref. No. Kit 1	Ölçüler /Dimensions	Segman /Rings	Pim	Gömlek /Liner	Kit 2	Info
       							
ø84,00 4/6 Cyl. Diesel 2926 cc 135 Kw (184 Ps) M57D30 M47D20R TD6 1999 -.... Freelander Range Rover TD6 2002	17-6592960 STD 17-6592963 0.50	A = 47,000 C = 16,500 E = -1,360 F = -1,480 G = 71,000 CD= 41,550 Segman Taşıyıcı (Ring Carrier) Yag Galerisi (Oil Gallery)	RE15410000 -STD RE15410050 -0.50 3,000 (504) Cr 2,000 (508) P 3,000 (604) Cr P	ø30,0 x 68,0			1. Kertik conta +0,80 +0,90 2. Kertik conta +0,90 +1,00
ø85,00 4 Cyl. Benzin 1895 cc 87 Kw (118 Ps) M43B 19 E46. 4 Sil. Benzinli 1895 cc 87 Kw (118 Ps) 1998 -.... Z3 318i	18-5510340 STD 18-5510343 0.50	A = 30,400 B = 53,900 C = 4,000 CD= 70,000 Sert Anotlama (Hard Anodising) Sac Plaka (Steel Support)	RE15220000 -STD RE15220050 -0.50 RE15220100 -1.00 1,200 (500) NitS IF 1,500 (508) P 2,000 (700) Nit S	ø22,0 x 53,8			

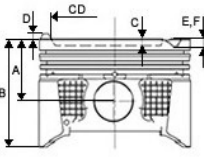







							
Motor /Engine	Ref. No. Kit 1	Ölçüler /Dimensions	Segman /Rings	Pim	Gömlek /Liner	Kit 2	Info
<p>ø89,00</p> <p>4 Cyl. Benzin 1990 cc 73,5 Kw (97 Ps) 121 M10. 4 Sil. Benzinli 1990 cc 73.5 Kw (97 Ps) 8 <u>1965 - 1975</u></p> <p><u>BMW 2000</u> 2002 320 520 1965-1975</p>	<p>18-5510380 STD 18-5510383 0.50</p>	<p>A = 42,300 B = 80,300</p> <p>Sac Plaka (Steel Support)</p>	<p>RE15090000 -STD RE15090050 -0.50 RE15090100 -1.00</p> <p>1,750 (500) Cr S IF 2,000 (508) P 4,000 (604) P</p>	<p>ø22,0 x 71,0</p>			
<p>ø92,00</p> <p>8 Cyl. Benzin 4395cc 210/212 kW/286 PS M62 B44 LEV <u>1996 -....</u></p> <p>540i 740i 840i X5 RANGE ROVER III 4.4</p>	<p>17-5510010 STD 17-5510013 0.50</p>	<p>A = 31,300 E = -2,950 F = -53,300</p> <p>Sert Anotlama (Hard Anodising)</p>	<p>RE15450000 -STD RE15450050 -0.50 RE15450100 -1.00</p> <p>1,500 (500) Nit S 1,500 (508) P 2,000 (700) Nit S</p>	<p>ø22,0 x 60,0</p>			



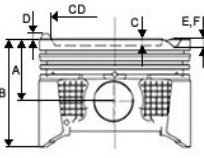







							
Motor /Engine	Ref. No. Kit 1	Ölçüler /Dimensions	Segman /Rings	Pim	Gömlek /Liner	Kit 2	Info
<p>ø68,50</p> <p>4 Cyl. Benzin cc</p> <p>Kalos 1.2 8v</p> <p>.... -</p> <p>KALOS 1.2 8v</p>	<p>18-1010110 STD</p> <p>18-1010113 0.50</p>	<p>A = 25,950</p> <p>B = 53,000</p> <p>C = 3,500</p> <p>E = -3,600</p> <p>F = -3,900</p>	<p>RJ40065A00 -STD</p> <p>RJ40065C00 -0.50</p> <p>1,200 () SV</p> <p>1,200 ()</p> <p>2,500 ()</p>	<p>ø17,0</p> <p>x 53,5</p>			
<p>ø69,70</p> <p>4 Cyl. Benzin 1229cc</p> <p>63kw</p> <p>86 PS</p> <p>1T2G1</p> <p>2010 -</p> <p>Aveo II 1.2i 16V</p> <p>Corsa D 1.2i 16V</p>	<p>18-1010150 STD</p> <p>18-1010153 0.50</p>	<p>A = 27,720</p> <p>B = 47,720</p> <p>C = 4,300</p> <p>E = -1,100</p> <p>F = -1,570</p> <p>CD= 63,300</p> <p>Yag Püskürt. Oyugu (Oil Cut-Out)</p>	<p>RE16010000 -STD</p> <p>RE16010050 -0.50</p> <p>1,200 (300)</p> <p>1,200 (300)</p> <p>2,000 (300)</p>	<p>ø17,0</p> <p>x 53,5</p>			



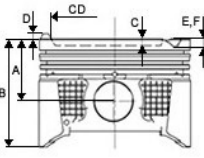





							
Motor /Engine	Ref. No. Kit 1	Ölçüler /Dimensions	Segman /Rings	Pim	Gömlek /Liner	Kit 2	Info
<p>ø73,40</p> <p>4 Cyl. Benzin 1229cc 63 kw/ 86 PS A12XER Euro 5 <u>2010 -</u></p> <p>Aveo II 1.2i 16V Corsa D 1.2i 16V</p>	<p>18-1010140 STD 18-1010143 0.50</p>	<p>A = 26,900 B = 48,550 D = 0,650 E = -1,350 F = -3,950 CD= 54,600</p> <p>Sert Anotlama (Hard Anodising)</p>	<p>RE43390000 -STD RE43390050 -0.50</p> <p>1,200 (500) NitBS 1,200 (508) P 2,000 (700) CrPS</p>	<p>ø18,0 x 52,3</p>			
<p>ø77,88</p> <p>4 Cyl. Benzin</p> <p>F14S <u>2006 -</u></p> <p>F14S-Aveo 1,4 Kalos 1,4 2006></p>	<p>18-1010200 STD 18-1010203 0.50</p>	<p>A = 32,000 B = 50,000 C = 3,600 CD= 64,000</p>	<p>RE16000000 -STD RE16000050 -0.50</p> <p>1,200 (500) CrB S IF 1,500 (508) P 2,500 (700) Cr P S</p>	<p>ø18,0 x 59,0</p>			



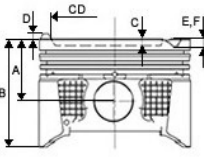









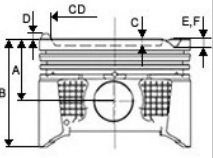





							
Motor /Engine	Ref. No. Kit 1	Ölçüler /Dimensions	Segman /Rings	Pim	Gömlek /Liner	Kit 2	Info
<p>ø77,90</p> <p>G14D 1.4 16V 2008 - F14D 1.4 16V</p>	<p>18-1010190 STD 18-1010193 0.50</p>	<p>A = 27,100 B = 45,100 D = 1,400 E = -2,500 F = -2,600</p> <p>Sert Anotlama (Hard Anodising)</p>	<p>RK10107790010 -STD RK10107790013 -0.50</p> <p>1,200 () CrI SV 1,200 () 2,000 () CrI</p>	<p>ø19,0 x 50,0</p>			
<p>ø77,90</p> <p>4 Cyl. Benzin</p> <p>1399 cm³ 55 kW (75 hp) 4NB 5HB F14D 16 Valf</p> <p>Aveo 1,4 Kalos 1,4 Lacetti 1,4 2002></p>	<p>18-1010210 STD 18-1010213 0.50</p>	<p>A = 31,900 B = 51,900 C = 1,400 E = -1,400 F = -0,700 CD= 43,000</p>	<p>RE16000000 -STD RE16000050 -0.50</p> <p>1,200 (500) CrB S IF 1,500 (508) P 2,500 (700) Cr P S</p>	<p>ø18,0 x 55,0</p>			



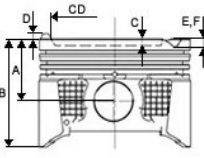







							
Motor /Engine	Ref. No. Kit 1	Ölçüler /Dimensions	Segman /Rings	Pim	Gömlek /Liner	Kit 2	Info
<p>ø79,00</p> <p>4 Cyl. Benzin 1598 cm³ 55 kW (75 hp) 8 6:1 A16DM A16 MF</p> <p>Lanos Nubira</p>	<p>18-1010250 STD 18-1010251 0.25 18-1010253 0.50 18-1010258 1.00</p>	<p>A = 28,300 B = 51,300 C = 3,000 E = -1,700 F = -1,700 CD= 60,000</p>	<p>RE43320000 -STD RE43320025 -0.25 RE43320050 -0.50 RE43320100 -1.00</p> <p>1,200 (500) CrB S 1,500 (508) P 2,500 (700) Cr P S</p>	<p>ø18,0 x 55,0</p>			
<p>ø79,00</p> <p>4 Cyl. Benzin 1598 cm³ 55 kW (75 hp) 8 6:2 F16D</p> <p>Aveo Optra Lacetti</p>	<p>18-1010260 STD 18-1010261 0.25 18-1010263 0.50 18-1010268 1.00</p>	<p>A = 27,800 B = 49,800 C = 2,600 E = -1,600 F = -1,200 CD= 63,850</p>	<p>RE43090000 -STD RE43090025 -0.25 RE43090050 -0.50 RE43090100 -1.00</p> <p>1,200 (500) CrB S 1,500 (508) P 3,000 (700) Cr S P</p>	<p>ø18,0 x 55,0</p>			



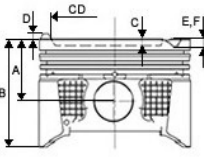



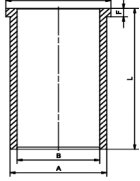

							
Motor /Engine	Ref. No. Kit 1	Ölçüler /Dimensions	Segman /Rings	Pim	Gömlek /Liner	Kit 2	Info
<p>ø79,00</p> <p>4 Cyl. Benzin</p> <p>1598 cm³ CRUZE RP 00 011 J 300 1.6L 16V</p> <p>CRUZE RP 00-011 J300 1.6L 16V 2010-...</p>	<p>18-1010270 STD 18-1010273 0.50</p>	<p>A = 27,100 B = 44,700 E = -2,600 F = -2,600</p> <p>Sert Anotlama (Hard Anodising)</p>	<p>RE43490000 -STD RE43490050 -0.50 RE43490100 -1.00</p> <p>1,200 (500) NitB S 1,200 (501) P 2,000 (700) Cr P S</p>	<p>ø19,0 x 50,0</p>			
<p>ø80,50</p> <p>4 Cyl. Benzin, 1796 cm³ 85 kW (115 hp) Z18XER 2000 -....</p> <p>Astra H 1.8i 16V Zafira B 1.8i 16V Vectra C 1.8i 16V Signum 1.8i 16V</p>	<p>18-3010830 STD 18-3010833 0.50 18-3010838 1.00</p>	<p>A = 26,100 B = 45,100 D = 0,700</p> <p>Sert Anotlama (Hard Anodising)</p>	<p>RE43370000 -STD RE43370050 -0.50 RE43370100 -1.00</p> <p>1,200 (500) NitB S IF 1,200 (508) P 2,000 (700) Nit S</p>	<p>ø19,0 x 50,0</p>			



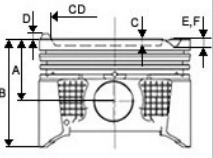



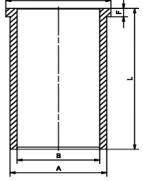

Motor /Engine	Ref. No. Kit 1	Ölçüler /Dimensions	Segman /Rings	Pim	Gömlek /Liner	Kit 2	Info
       							
ø83,00 4 Cyl. Diesel 1991cc 110 Kw(150 BG) Z20S Z20DMH 2006 - CAPTIVA 2.0 16V D ANTARA 2.0 CDTI 16V	18-1092500 STD 18-1092503 0.50	A = 46,350 B = 72,350 C = 13,950 CD= 46,700 Segman Taşıyıcı (Ring Carrier) Yag Galerisi (Oil Gallery)	RE43460000 -STD RE43460000_NPR -STD RE43460050 -0.50 2,000 (505) Nit S 2,000 (501) P 3,000 (604) Nit S	ø28,0 x 66,8			1 kertik 0.11 0.23 2 kertik 0.24 0.33 3 kertik 0.34 0.42
ø84,00 4 Cyl. Diesel 1995 cc 74 Kw (101 Ps) 18,5:1 Turbo, Intercooler 24 v Y20DTH 08/2002 - ASTRA 2.0 DTI GLS ASTRA 2.0 DTI ASTRA-G 2.0 DI ASTRAMAN IV 2.0 DTI SIGNUM 2.0 DTI VECTRA I/II 2. DTI ZAFIRA I 2.0 DTI	18-3092990 STD 18-3092993 0.50	A = 45,800 B = 70,800 C = 14,900 E = -1,000 CD= 41,000	RE43350000 -STD RE43350050 -0.50 RE43350100 -1.00 1,750 (500) Cr P 1,750 (501) P 3,000 (604) Cr P	ø29,0 x 62,0			

							
Motor /Engine	Ref. No. Kit 1	Ölçüler /Dimensions	Segman /Rings	Pim	Gömlek /Liner	Kit 2	Info
<p>ø84,80</p> <p>4 Cyl. Benzin, 1796 cm³ 60 74 kW (82 101 PS) 1.8S <u>1986-1988</u></p> <p>Astra Corca Kadett Vectra</p>	<p>18-3010490 STD 18-3010493 0.50</p>	<p>A = 33,650 B = 53,650 C = 5,000 CD= 52,000</p>	<p>RE43160000 -STD RE43160050 -0.50 RE43160100 -1.00</p> <p>1,500 (500) CrB S IF 1,500 (508) P 3,000 (700) Cr S P</p>	<p>ø21,0 x 61,5</p>			
<p>ø86,00</p> <p>4 Cyl. Diesel 2.0 Z20D1 <u>20011-</u></p> <p>Orlando(J309) Cruze(J300) Cruze Schragheck(J305-J308)</p>	<p>18-1092510 STD 18-1092513 0.50</p>	<p>A = 52,900 B = 80,900 C = 14,900 F = -0,340 CD= 48,200</p> <p>Segman Taşıyıcı (Ring Carrier)</p> <p>Yag Galerisi (Oil Gallery)</p>	<p>RE16060000 -STD RE16060050 -0.50</p> <p>1,800 () 1,500 () P 2,000 ()</p>	<p>ø32,0 x 70,0</p>			

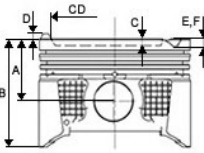





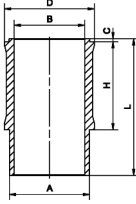

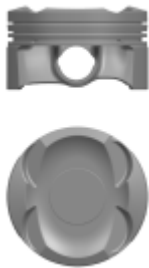



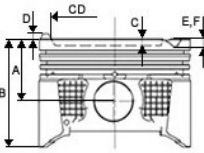



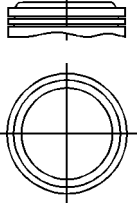
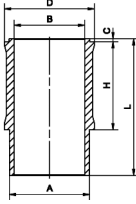
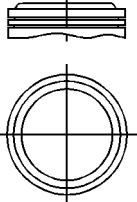
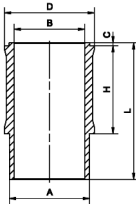

							
Motor /Engine	Ref. No. Kit 1	Ölçüler /Dimensions	Segman /Rings	Pim	Gömlek /Liner	Kit 2	Info
<p>ø86,00</p> <p>4 Cyl. Benzin, 1998 cm³ 85 95 kW 20NE C20NE</p> <p><u>1986-1998</u></p> <p>Omega Kadett Ascona Vectra Le Mans 2,0 Espero 2,0 Frontera</p>	<p>18-3010630 STD 18-3010633 0.50 18-3010638 1.00</p>	<p>A = 30,400 B = 55,400 C = 5,000 CD= 57,000</p> <p>Sac Plaka (Steel Support)</p>	<p>RE43190000 -STD RE43190050 -0.50 RE43190100 -1.00</p> <p>1,500 (500) CrB S 1,500 (501) P 3,000 (700) Cr P S</p>	<p>ø21,0 x 61,5</p>	<p>G89001350K_1</p> <p>A= 89,000 B= 85,300 D= 90,000 F= 5,000 H= 0,000 L= 135,000</p> 		
<p>ø86,00</p> <p>4 Cyl. Benzin, 1998/2198 cm³ 85/94/96/98 100/101/102 kW 116/128/131/133 136/137/139 PS C20 SEL X22 SE/XE/SEL</p> <p><u>1998-2000</u></p> <p>Omega Kadett Ascona Vectra Leganza Frontera</p>	<p>18-3010730 STD 18-3010733 0.50</p>	<p>A = 30,400 B = 55,400 C = 6,500 CD= 63,180</p>	<p>RE43190000 -STD RE43190050 -0.50 RE43190100 -1.00</p> <p>1,500 (500) CrB S 1,500 (501) P 3,000 (700) Cr P S</p>	<p>ø21,0 x 61,5</p>			



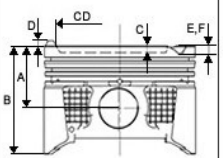



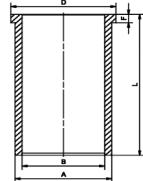
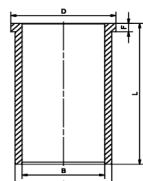

Motor /Engine	Ref. No. Kit 1	Ölçüler /Dimensions	Segman /Rings	Pim	Gömlek /Liner	Kit 2	Info
							
ø86,00 4 Cyl. Benzin 1998 cc 94/100 Kw128/136 PS Catal.Conv, 16 v X20XEV <u>1994-2000</u> Omega Kadett Ascona Vectra	18-3010780 STD 18-3010780-20 STD (-0.20 mm) 18-3010783 0.50 18-3010783-20 0.50 (-0.20 mm) 18-3010788 1.00	A = 30,400 B = 55,400 C = 3,160 E = -1,650 CD= 59,000	RE43190000 -STD RE43190050 -0.50 RE43190100 -1.00 1,500 (500) CrB S 1,500 (501) P 3,000 (700) Cr P S	ø21,0 x 61,5	G89001350K_1 A= 89,000 B= 85,300 D= 90,000 F= 5,000 H= 0,000 L= 135,000 		
ø101,60 8 Cyl. Benzin 5700/5735 cc 5.7L (350CID,5733CC) OHV 8CYL Chevy S.B.350/L83/L98 Vortec 5700 L31 <u>1996 - 2022</u> BLAZER CABALLERO CAMARA CHEVY VAN CORVETTE FIREBIRD JIMMY MAGNAVAN MALIBU MONTE CARLO PICKUP RALL SPORTVAN SUBURBAN TRANS AM VANDURA YUKON TAHOE SAVANA EXPRESS CUTAWAY	17-9710310 STD 17-9710313 0.50 17-9710318 1.00	A = 39,400 B = 66,000 C = 2,600 E = -5,200 F = -5,200 CD= 70,100		ø23,6 x 70,0			



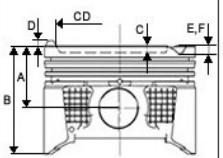



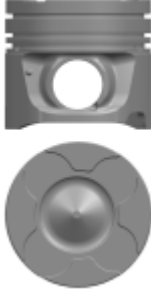
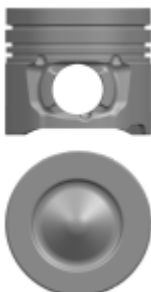
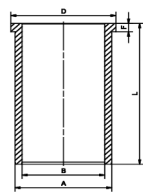

							
Motor /Engine	Ref. No. Kit 1	Ölçüler /Dimensions	Segman /Rings	Pim	Gömlek /Liner	Kit 2	Info
<p>ø70,00</p> <p>4 Cyl. Benzin 954 cc 31/33/37 42/45/50 ps TU9M/Z <u>1992 -</u> 205 1.0i 106 1.0i</p>	<p>18-7510510 STD Gömlikli Kodu 19-7510510 STD</p>	<p>A = 33,900 B = 58,000 D = 0,800</p>	<p>RE47360000 -STD RE47360050 -0.50</p> <p>1,500 (500) CrBSIF 1,500 (501) P 3,000 (700) CrPS</p>	<p>ø18,0 x 53,0</p>	<p>G79501220S_1</p> <p>A= 79,500 B= 70,000 D= 89,300 F= 0,000 H= 85,000 L= 122,000</p> 		
<p>ø71,00</p> <p>3 Cyl. Benzin 999 cc 50 kW 68 PS ZMZ (EBO EBOF) <u>2012 - 2019</u> ZMZ (EBO-EBOF)</p>	<p>17-7510080 STD 17-7510083 0.50</p>	<p>A = 28,650 B = 42,150 C = 4,400 E = -5,100 F = -6,100</p> <p>Sert Anotlama (Hard Anodising)</p>	<p>RE47680000 -STD RE47680050 -0.50</p> <p>1,000 () 1,000 () 2,000 ()</p>	<p>ø17,0 x 45,0</p>			



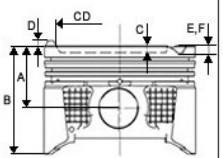





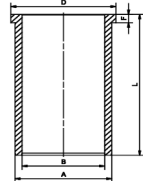
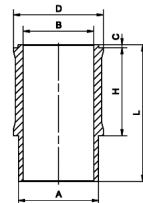



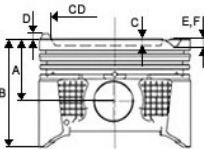





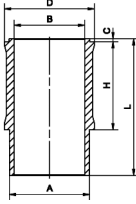
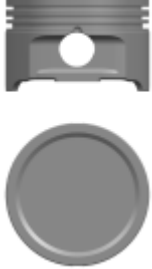
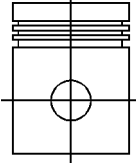

							
Motor /Engine	Ref. No. Kit 1	Ölçüler /Dimensions	Segman /Rings	Pim	Gömlek /Liner	Kit 2	Info
<p>ø72,00</p> <p>4 Cyl. Benzin, 1124 cm³ 37 kW (50 hp), 9,7:1 XW7 <u>1981 - 1986</u></p> <p>104 205</p>	<p>18-7510070 STD Gömleklili Kodu 19-7510070 STD</p> 	<p>A = 40,050 B = 73,700 D = 4,200</p>	<p>RE18020000 -STD</p> <p>1,500 (500) Cr S 2,000 (501) P 4,000 (700) Cr P S</p>	<p>ø19,5 x 62,0</p>	<p>G79501220S_2</p> <p>A= 79,500 B= 72,000 D= 89,300 F= 0,000 H= 85,000 L= 122,500</p> 		
<p>ø72,00</p> <p>4 Cyl. Benzin, 1124 cm³ 40 kW (54 hp) TU1 E1 A TU1K TU 1M XW3 XW3S XW7/A <u>1988-1992</u></p> <p>106 205 306 309 Partner</p>	<p>18-7510130 STD Gömleklili Kodu 19-7510130 STD</p> 	<p>A = 40,000 B = 67,000 D = 3,000</p>	<p>RE18020000 -STD</p> <p>1,500 (500) Cr S 2,000 (501) P 4,000 (700) Cr P S</p>	<p>ø19,5 x 62,0</p>	<p>G79501220S_2</p> <p>A= 79,500 B= 72,000 D= 89,300 F= 0,000 H= 85,000 L= 122,500</p> 		

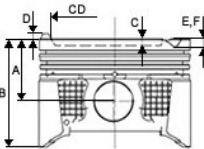





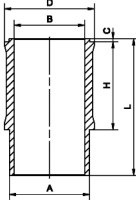

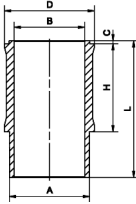
Motor /Engine	Ref. No. Kit 1	Ölçüler /Dimensions	Segman /Rings	Pim	Gömlek /Liner	Kit 2	Info
							
ø73,70 4 Cyl. Diesel 1399 cc 50 Kw (68 Ps) DV4TD DV4 TED DV4C TED F6JA F6JB 8HX 8HR 8HZ 8HS 2002 -.... Fiesta V 1.4 TDCI Fusion 1.4 TDCI Mazda 2 1,4D C2 1.4 HDI C3 I 1.4 HDI XSARA 1.4 HDI NEMO 1.4 HDI 1007 1.4 HDI 107 1.4 HDI 206 1.4 HDI 207 1.4 HDI 307 1.4 HDI BIPPER 1.4 HDI	18-2550150 STD 18-2550150-20 STD (-0.20 mm) 18-2550150-40 STD (-0.40 mm) 18-2550153 0.50 18-2550153-20 0.50 (-0.20 mm) 18-2550153-40 0.50 (-0.40 mm)	A = 42,940 B = 65,440 C = 14,700 E = -1,550 CD= 37,600 Segman Taşıyıcı (Ring Carrier) Yag Püskürt. Oyugu (Oil Cut-Out)	RK25273700010 -STD RK25273700013 -0.50 2,500 (505) Cr B P 1,950 (508) P IFU 2,500 (604) Cr P	ø25,0 x 60,0	G76701360K_1 A= 76,700 B= 73,000 D= 78,200 F= 5,000 H= 0,000 L= 136,000 	1 çentik 1,351mm conta +0,776 +0,825 2 çentik 1,252mm conta +0,618 +0,725 3 çentik 1,303mm conta +0,726 +0,775 4 çentik 1,400mm conta +0,83 +0,88 5 çentik 1,450mm conta +0,88 0,98	
ø73,70 4 Cyl. Diesel 1398cc 68 HP 50 KW DV4C Euro 5 2010 -.... Fiesta V 1.4 TDCI	18-2550160 STD 18-2550163 0.50	A = 42,900 B = 65,400 C = 12,500 CD= 45,100 Segman Taşıyıcı (Ring Carrier) Yag Püskürt. Oyugu (Oil Cut-Out)	RE23580000 -STD RE23580050 -0.50 2,500 (514) Cr P 1,950 (508) P IFU 2,000 (604) Nit S	ø25,0 x 60,0	G73701360K_1 A= 76,700 B= 68,900 D= 78,200 F= 5,000 H= 0,000 L= 142,000 		

Motor /Engine	Ref. No. Kit 1	Ölçüler /Dimensions	Segman /Rings	Pim	Gömlek /Liner	Kit 2	Info
							
ø73,70 4 Cyl. Diesel, 1398 cm ³ 50/66kW (68PS/90PS) 17,5:1,16 Ventile,T 8HY (DV4TED4) 8HS (DV4TED), Euro 4 <u>02/2002...04/2005</u> C3 I 1.4 HDI Peugeot Turbo	18-7592160 STD 18-7592161 0.25 18-7592163 0.50	A = 42,940 B = 65,440 C = 14,390 E = -1,180 CD= 37,160	RE23050000 -STD RE23050050 -0.50 2,500 (505) CrB P 1,950 (508) P IFU 2,500 (604) Cr P	ø24,9 x 60,0			
		Segman Taşıyıcı (Ring Carrier) Yag Galerisi (Oil Gallery) Yag Püskürt. Oyugu (Oil Cut-Out)					
ø75,00 4 Cyl. Diesel 1560cc 70 Kw (95 Ps) 1.6 HDİ (DV6C) EUR5 1.6 HDİ (DV6D) Euro 4 <u>2011 -</u> FOCUS BERLINGO 1.6 8V C4 (B7) DS4 (9HR-9HL) DS5 Grand Picasso II C4 DS4 DS3 C3 C3 II 3008 308 5008 508 Partner Tepee 2008 308 SW 207 SW 208 207	18-2581660 STD 18-2581660-20 STD (-0.20 mm) 18-2581660-40 STD (-0.40 mm) 18-2581663 0.50 18-2581663-20 0.50 (-0.20 mm) 18-2581663-40 0.50 (-0.40 mm)	A = 41,750 B = 65,200 C = 13,850 CD= 45,000	RE23550000 -STD RE23550050 -0.50 2,500 (514) Cr P 1,950 (508) P 2,000 (604) Nit S	ø26,0 x 61,0	G78001420K_1 A= 78,000 B= 74,300 D= 79,500 F= 5,000 H= 0,000 L= 142,000		1 Kertik 0,5 mm 0,63 mm 2 Kertik 0,63 mm 0,68 mm 3 Kertik 0,68 mm 0,73 mm 4 Kertik 0,73 mm 0,78 mm 5 Kertik 0,78 mm 0,88 mm
		Segman Taşıyıcı (Ring Carrier) Yag Galerisi (Oil Gallery) Yag Püskürt. Oyugu (Oil Cut-Out)					

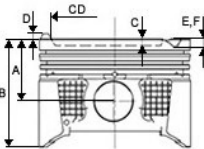





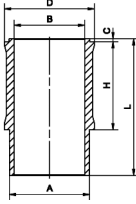

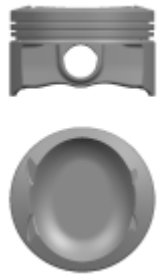
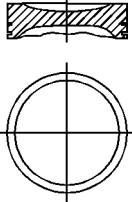
Motor /Engine	Ref. No. Kit 1	Ölçüler /Dimensions	Segman /Rings	Pim	Gömlek /Liner	Kit 2	Info
							
ø75,00 4 Cyl. Diesel 1560 cc 80 Kw (109 Ps) DV6TD/TED 2004 -.... Expert 1,6 HDI 307 1,6 HDI 206 1,6 HDI C4 1,6 HDI Jumpy 1,6 HDI C-Max 1,6 HDI Focus 1,6 HDI	18-2591770 STD 18-2591770-20 STD (-0.20 mm) 18-2591770-40 STD (-0.40 mm) 18-2591773 0.50 18-2591773-20 0.50 (-0.20 mm) 18-2591773-40 0.50 (-0.40 mm) 18-2591774 0.60 18-2591774-20 0.60 (-0.20 mm) 18-2591774-40 0.60 (-0.40 mm)	A = 41,700 B = 65,300 C = 13,250 E = -1,200 CD= 41,800 Segman Taşıyıcı (Ring Carrier) Yag Galerisi (Oil Gallery) Yag Püskürt. Oyugu (Oil Cut-Out)	RE47460000 -STD RE47460040 -0.40 RE47460050 -0.50 RE47460060 -0.60 3,000 (505) CKP 1,950 (508) P 2,500 (604) CrP	ø26,0 x 61,0	G78001420K_1 A= 78,000 B= 74,300 D= 79,500 F= 5,000 H= 0,000 L= 142,000		1.35 mm conta +0,68 +0,73 1.25 mm conta +0,53 +0,63 1.30 mm conta +0,63 +0,68 1.40 mm conta +0,73 +0,78 1.45 mm conta +0,78 +0,88
ø75,00 4 Cyl. Benzin, 1361 cm ³ 55 kW (75 hp), 10,5:1 Düz Tepe TU3JPL4 KFW(TU3JP) KFX(TU3JP) 2004 -.... Berlingo 1.4 I Saxo 1.4 I Xsara 1.4 I 106 II 1.4 I 205 II 1.4 I 206 1.4 I 306 1.4 I 307 1.4 I Partner 1.4 I	18-7510060 STD Gömleklili Kodu 19-7510060 STD 18-7510063 0.50 Gömleklili Kodu 19-7510063 0.50	A = 27,750 B = 49,930	RE47580000 -STD RE47580050 -0.50 1,500 (500) CrB Fe S IF 1,500 (501) P 2,500 (700) Cr P S	ø18,0 x 55,0	G79501350S_1 A= 79,500 B= 75,000 D= 89,300 F= 0,000 H= 90,000 L= 135,000		

							
Motor /Engine	Ref. No. Kit 1	Ölçüler /Dimensions	Segman /Rings	Pim	Gömlek /Liner	Kit 2	Info
<p>ø75,00</p> <p>4. Cyl. Benzin 1361cc 54/55 kW 73/75 PS TU3JP <u>2005 -</u></p> <p><i>PARTNER 1.4i</i> 1007 1.4i 307 1.4i 306 1.4i 206 1.4i <i>RANCH 1.4i</i> 106 1.4i</p>	<p>18-7510090 STD Gömlikli Kodu 19-7510090 STD</p>	<p>A = 27,850 B = 49,700 C = 1,250 CD= 65,000</p>	<p>RE47580000 -STD RE47580050 -0.50</p> <p>1,500 (500) CrB Fe S IF 1,500 (501) P 2,500 (700) Cr P S</p>	<p>ø18,0 x 55,0</p>	<p>G79501350S_1</p> <p>A= 79,500 B= 75,000 D= 89,300 F= 0,000 H= 90,000 L= 135,000</p> 		
<p>ø75,00</p> <p>4 Cyl. Benzin, 1218 cm³ 42 kW (57 hp) XZ5 XY6B XY7 XYB XYR <u>1978 - 1984</u></p>	<p>18-7510100 STD</p>	<p>A = 28,250 B = 52,330 D = 1,300 E = -3,100</p>	<p>RE47000000 -STD RE47000050 -0.50</p> <p>1,750 (500) CrBSIF 2,000 (508) P 3,000 (700) CrPS</p>	<p>ø19,5 x 62,0</p>			

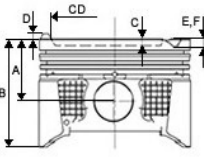







							
Motor /Engine	Ref. No. Kit 1	Ölçüler /Dimensions	Segman /Rings	Pim	Gömlek /Liner	Kit 2	Info
<p>ø75,00</p> <p>4 Cyl. Benzin, 1361 cm³ 65 kW (88 hp) KFU(ET 3 J4) <u>2003 -....</u></p> <p><i>C 2 1.4 I</i> <i>C 3 1.4 I</i> <i>C 4 1.4</i> <i>1007 1.4 I</i> <i>206 1.4</i> <i>207 1.4</i> <i>307 1.4</i></p> 	<p>18-7510110 STD Gömleklı Kodu 19-7510110 STD 18-7510113 0.50 Gömleklı Kodu 19-7510113 0.50</p>	<p>A = 28,250 B = 52,330 D = 1,300 E = -3,100</p>	<p>RE47590000 -STD RE47590050 -0.50</p> <p>1,200 (500) Cr P 1,500 (508) P 2,500 (604) P</p>	<p>ø18,0 x 44,5</p>	<p>G79501350S_1</p> <p>A= 79,500 B= 75,000 D= 89,300 F= 0,000 H= 90,000 L= 135,000</p> 		
<p>ø75,00</p> <p>4 Cyl. Benzin, 1361 cm³ 55 kW (75 hp), 10,5:1 TU3JPL4 KFW(TU3JP) KFX(TU3JP) <u>2004 -....</u></p> <p><i>Berlingo 1.4 I</i> <i>Saxo 1.4 I</i> <i>Xsara 1.4 I</i> <i>106 II 1.4 I</i> <i>205 II 1.4 I</i> <i>206 1.4 I</i> <i>306 1.4 I</i> <i>307 1.4 I</i> <i>Partner 1.4 I</i></p> 	<p>18-7510120 STD Gömleklı Kodu 19-7510120 STD 18-7510123 0.50 Gömleklı Kodu 19-7510123 0.50</p>	<p>A = 27,750 B = 49,930 D = 0,180</p>	<p>RE47580000 -STD RE47580050 -0.50</p> <p>1,500 (500) CrB Fe S IF 1,500 (501) P 2,500 (700) Cr P S</p>	<p>ø18,0 x 55,0</p>	<p>G79501350S_1</p> <p>A= 79,500 B= 75,000 D= 89,300 F= 0,000 H= 90,000 L= 135,000</p> 		

							
Motor /Engine	Ref. No. Kit 1	Ölçüler /Dimensions	Segman /Rings	Pim	Gömlek /Liner	Kit 2	Info
<p>ø75,00</p> <p>4 Cyl. Benzin, 1361 cm³ 44 55 kW (60 75 hp) 9,3:1 TU3A <u>1987-1992</u></p> <p>106 205 206 306 309 Partner</p>	<p>18-7510270 STD Gömleklili Kodu 19-7510270 STD 18-7510273 0.50 Gömleklili Kodu 19-7510273 0.50</p>	<p>A = 40,500 B = 64,500 C = 1,100 CD= 63,000</p>	<p>RE47000000 -STD RE47000050 -0.50</p> <p>1,750 (500) CrBSIF 2,000 (508) P 3,000 (700) CrPS</p>	<p>ø19,5 x 62,0</p>	<p>G79501350S_1</p> <p>A= 79,500 B= 75,000 D= 89,300 F= 0,000 H= 90,000 L= 135,000</p> 		
<p>ø75,00</p> <p>3 Cyl. Benzin. 1199cc 53kW (72ps) 1.2 VTi (72 Hp) Euro 5 EB2 M 301 1.2 16V <u>2012 -....</u></p> <p>C-Elysee 1.2 VTi 301 1.2 VTi</p>	<p>17-7511270 STD 17-7511273 0.50</p>	<p>A = 28,810 B = 46,820 C = 8,000 E = -1,200 CD= 64,500</p> <p>Sert Anotlama (Hard Anodising)</p>	<p>RE18520000 -STD RE18520050 -0.50</p> <p>1,000 (910) NIT SY 1,000 (931) FE S 2,000 (947) EX NIT S</p>	<p>ø17,0 x 51,0</p>			

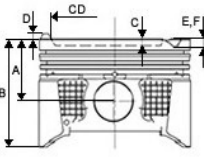











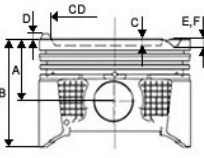





							
Motor /Engine	Ref. No. Kit 1	Ölçüler /Dimensions	Segman /Rings	Pim	Gömlek /Liner	Kit 2	Info
<p>ø75,00</p> <p>3 Cyl.Benzin.1199cc 50/55/60/61kW 68/75/82/83 PS 1.2 l HMM EB2FAD HMP EB2FB HMX EB2 MHZEB2 D/F 12 XE EB2FA</p> <p><u>2012 -....</u></p> <p>1,2 VTi (82 Hp) Euro 5-EB2 108 2008 208 308II-D 12 XE F 12 XE</p>	<p>17-7511280 STD 17-7511283 0.50</p>	<p>A = 26,500 B = 45,000 C = 5,300</p> <p>Sert Anotlama (Hard Anodising)</p>	<p>RE18520000 -STD RE18520050 -0.50</p> <p>1,000 (910) NIT SY 1,000 (931) FE S 2,000 (947) EX NIT S</p>	<p>ø17,0 x 51,0</p>			
<p>ø75,00</p> <p>3 Cyl.Benzin.1199 cc 81/96kW 110/130/131 EB2DTS EB2DT 1.2 12V e THP 110/130</p> <p><u>2013/01 -....</u></p> <p>208 I (CA, CC) 308 II/SW II 2008 (CU) 3008 MPV (OU,)/SUV (M,) 5008 (OU, OE,)/II PARTNER Tepée</p>	<p>17-7511290 STD 17-7511293 0.50</p>	<p>A = 28,450 B = 50,000 D = 4,700 E = -4,200 F = -3,300</p> <p>Sert Anotlama (Hard Anodising)</p>	<p>RE47660000 -STD RE47660050 -0.50</p> <p>1,200 () 1,000 () 2,000 ()</p>	<p>ø19,5 x 45,0</p>			



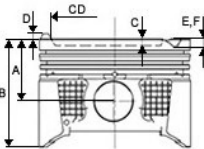







							
Motor /Engine	Ref. No. Kit 1	Ölçüler /Dimensions	Segman /Rings	Pim	Gömlek /Liner	Kit 2	Info
<p>ø77,00</p> <p>4 Cyl.Benzin 1598 cc 75/88/90/147 102/120/122/200 PS BMW N 13 B16A MINI N18 B 16A 5FU(EP6CDTX/EP6DTX) 5FW(EP6) <u>2010 -....</u></p> <p>BMW 116i MINI COOPER S 1.6i 16V PEUGEOT 77 MM</p>	<p>18-5510310 STD 18-5510310-30 STD 18-5510313 0.50 18-5510313-30 0.50</p>	<p>A = 28,500 B = 51,200 C = 3,500 D = 2,700 E = -3,300 F = -3,400 CD= 34,700</p> <p>Sert Anotlama (Hard Anodising)</p>	<p>RE15260000 -STD RE15260000_NPR -STD x 48,0 RE15260050 -0.50 RE15260050_NPR -0.50</p> <p>1,200 (500) Cr S IF 1,500 (508) P 2,000 (700) Cr P S</p>	<p>ø20,0 x 48,0</p>			
<p>ø77,00</p> <p>4 Cyl.Benzin 1598 cc EP6 EP6C <u>2010 -....</u></p> <p>3008 16i 16V 5008 1.6i 2 207 1.6 16V 308 1.6 16V</p>	<p>18-5510320 STD 18-5510323 0.50</p>	<p>A = 27,500 B = 47,500 C = 2,000 E = -5,700 F = -3,800 CD= 56,600</p>	<p>RE15260000 -STD RE15260000_NPR -STD x 43,0 RE15260050 -0.50 RE15260050_NPR -0.50</p> <p>1,200 (500) Cr S IF 1,500 (508) P 2,000 (700) Cr P S</p>	<p>ø18,0 x 43,0</p>			



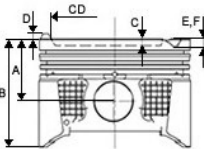





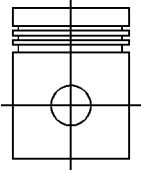
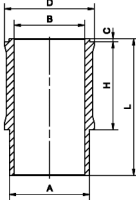
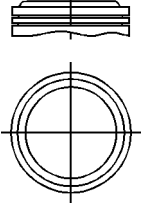



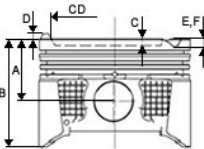





							
Motor /Engine	Ref. No. Kit 1	Ölçüler /Dimensions	Segman /Rings	Pim	Gömlek /Liner	Kit 2	Info
<p>ø77,00</p> <p>4 Cyl. Benzin 1598 cc (175PS) 115 156 PS 2010 ÖNCESİ EP6D1.6L R55 R56 R57 <u>2007-2010</u></p> <p>MINI COOPER 208 3008 308 508</p>	<p>18-5510330 STD 18-5510330-30 STD 18-5510333 0.50 18-5510333-30 0.50</p>	<p>A = 28,500 B = 51,200 C = 3,500 D = 2,700 E = -3,300 F = -3,400 CD= 34,700</p> <p>Sert Anotlama (Hard Anodising)</p>	<p>RE15260000 -STD RE15260000_NPR -STD x 48,0 RE15260050 -0.50 RE15260050_NPR -0.50</p> <p>1,200 (500) Cr S IF 1,500 (508) P 2,000 (700) Cr P S</p>	<p>ø20,0</p>			
<p>ø77,00</p> <p>4 Cyl. Benzin 1598 cc (175PS) EP6CDT 5FV 5FX 5FY EP6DT EP6DTS <u>2010 -</u></p> <p>207 3008 5008 508 RC23008 3008 I 3008 II 3008 SV</p>	<p>18-5510370 STD 18-5510373 0.50</p>	<p>A = 28,500 B = 51,200 C = 3,500 D = 2,700 E = -3,300 F = -3,400 CD= 34,700</p> <p>Sert Anotlama (Hard Anodising)</p>	<p>RE15260000 -STD RE15260000_NPR -STD x 48,0 RE15260050 -0.50 RE15260050_NPR -0.50</p> <p>1,200 (500) Cr S IF 1,500 (508) P 2,000 (700) Cr P S</p>	<p>ø20,0</p>			

							
Motor /Engine	Ref. No. Kit 1	Ölçüler /Dimensions	Segman /Rings	Pim	Gömlek /Liner	Kit 2	Info
<p>ø77,00</p> <p>4Cyl. Benzin 1.6 BlueHDi 100 1.6 16V 1.6HDi 1.6 1.6 THP <u>2009 - 2016</u></p> <p><i>C4 Grand Picasso II 308 CC (4B_) RCZ 308 SW Peugeot 3008/308 SW RCZ Citroen C6 DS</i></p>	<p>18-7510160 STD 18-7510163 0.50</p>	<p>A = 27,000 B = 47,000 C = 2,000 D = 3,500 CD= 34,800</p> <p>Sert Anotlama (Hard Anodising)</p>		<p>ø20,0 x 48,0</p>			
<p>ø77,00</p> <p>4 Cyl. Benzin 1397 cc 50/70 kW 75/95 PS EP3 N12B14A-.....</p> <p><i>207 WA/WC 1.4 16V 207 SW (WK) 1.4 16V 308 4A/4C 1.4 16V</i></p>	<p>18-7510280 STD 18-7510283 0.50</p>	<p>A = 27,600 B = 47,500 D = 3,100</p>	<p>RE15260000 -STD RE15260000_NPR -STD RE15260050 -0.50 RE15260050_NPR -0.50</p> <p>1,200 (500) Cr S IF 1,500 (508) P 2,000 (700) Cr P S</p>	<p>ø18,0 x 43,0</p>			

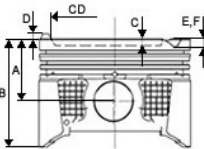











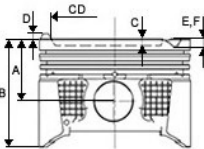



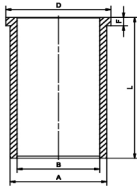
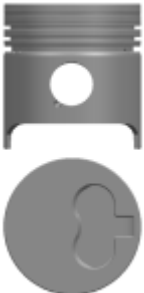

							
Motor /Engine	Ref. No. Kit 1	Ölçüler /Dimensions	Segman /Rings	Pim	Gömlek /Liner	Kit 2	Info
<p>ø78,00</p> <p>4 Cyl. Benzin, 1290 cm³ 44 48 kW (60 65 hp) XL5 <u>1976-1988</u> 305 SR</p>	<p>18-7510140 STD Gömleklili Kodu 19-7510140 STD 18-7510143 0.50 Gömleklili Kodu 19-7510143 0.50</p> 	<p>A = 36,100 B = 72,300</p>	<p>RE47400000 -STD RE47400050 -0.50</p> <p>1,750 (500) CrB S IF 2,000 (501) P 4,000 (604) P</p>	<p>ø20,5 x 68,0</p>	<p>G78451340S_1</p> <p>A= 78,450 B= 73,000 D= 88,000 F= 0,000 H= 94,850 L= 134,000</p> 		
<p>ø78,00</p> <p>4 Cyl. Benzin, 1472 cm³ 49 58 kW (67 79 hp) XR5 <u>1977-.....</u> 305 SR</p>	<p>18-7510150 STD 18-7510153 0.50</p> 	<p>A = 36,100 B = 73,100 D = 0,400</p>	<p>RE47400000 -STD RE47400050 -0.50</p> <p>1,750 (500) CrB S IF 2,000 (501) P 4,000 (604) P</p>	<p>ø20,5 x 68,0</p>			



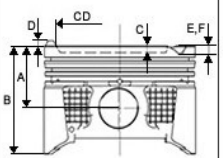



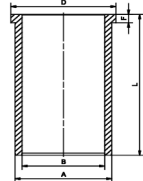
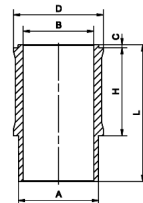

							
Motor /Engine	Ref. No. Kit 1	Ölçüler /Dimensions	Segman /Rings	Pim	Gömlek /Liner	Kit 2	Info
<p>ø78,50</p> <p>4 Cyl. Benzin 1587 cc 80 Kw (109 Ps) TU5JP4 Euro3 <u>2000 -....</u></p> <p>C3 1.6i 16V Berlingo 1.6i 16v 206 1.6i 16v 207 1.6i 16v 307 1.6i 16v Partner 1.6i 16v</p>	<p>18-7510700 STD 18-7510703 0.50</p>	<p>A = 32,350 B = 50,150 D = 0,150</p> <p>Yag Püskürt. Oyugu (Oil Cut-Out)</p>	<p>RE47380000 -STD RE47380025 -0.25 RE47380040 -0.40 RE47380050 -0.50 RE47380100 -1.00</p> <p>1,200 (500) MoB N S 1,500 (508) P 2,500 (604) P</p>	<p>ø19,6 x 57,0</p>			
<p>ø78,50</p> <p>4 Cyl. Benzin 1587 cc 80 Kw (118 Ps) 10,8:1 16 Ventile NFX (TU5J4) <u>05/1996 -....</u></p> <p>106 GTI 106 II 1.6 206 306 307</p>	<p>18-7510710 STD 18-7510711 0.25 18-7510713 0.50</p>	<p>A = 32,500 B = 57,800 C = 1,200</p>	<p>RE47280000 -STD RE47280000_NPR -STD RE47280025 -0.25 RE47280050 -0.50</p> <p>1,500 (500) Cr P S IF 1,500 (508) P 3,000 (700) Cr P S</p>	<p>ø19,5 x 59,0</p>			



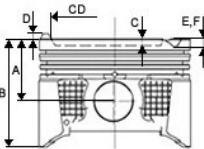





							
Motor /Engine	Ref. No. Kit 1	Ölçüler /Dimensions	Segman /Rings	Pim	Gömlek /Liner	Kit 2	Info
<p>ø78,50</p> <p>4 Cyl. Benzin 85 kw 115 HP EC5 1.6 VTI EURO 5 <u>2012 -</u> 301 C-ELYSEE</p>	<p>18-7510820 STD 18-7510823 0.50</p>	<p>A = 32,350 B = 53,750 D = 1,400 E = -2,450</p>	<p>RE47650000 -STD RE47650050 -0.50</p> <p>1,000 (500) Nit S IF 1,200 (508) P 2,000 (604) Nit S</p>	<p>ø19,6 x 57,0</p>			
<p>ø78,50</p> <p>4 Cyl. Benzin, 1587 cm³ 65 kW (88 hp) TU5JP <u>1996 - 1998</u> 1.6i (8v/16v) C3 Berlingo 206 307 Partner</p>	<p>18-7510880 STD 18-7510882 0.40 18-7510883 0.50</p>	<p>A = 32,250 B = 57,500 C = 1,500 CD= 68,500</p>	<p>RE47280000 -STD RE47280000_NPR -STD RE47280025 -0.25 RE47280050 -0.50</p> <p>1,500 (500) Cr P S IF 1,500 (508) P 3,000 (700) Cr P S</p>	<p>ø19,5 x 61,9</p>			



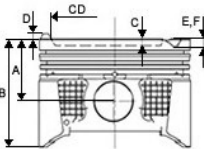





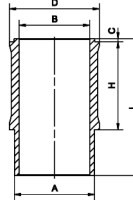
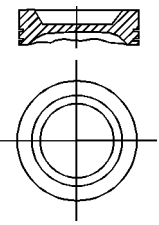
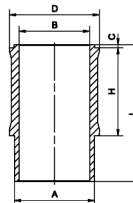
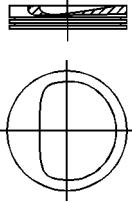

							
Motor /Engine	Ref. No. Kit 1	Ölçüler /Dimensions	Segman /Rings	Pim	Gömlek /Liner	Kit 2	Info
<p>ø80,00</p> <p>4 Cyl. Diesel 1768 cc 22:1 Turbo XUD7T TE TEY <u>1995 -....</u></p> <p>205 TD 309TD SRD GRD SXD XSD,405TD SRD GRD GTD</p>	<p>18-7550430 STD 18-7550433 0.50 18-7550437 0.80</p>	<p>A = 46,800 B = 84,500 C = 2,200</p> <p>Segman Taşıyıcı (Ring Carrier)</p> <p>Sert Anotlama (Hard Anodising)</p> <p>Yag Püskürt. Oyugu (Oil Cut-Out)</p>	<p>RE47050000 -STD RE47050050 -0.50 RE47050080 -0.80</p> <p>3,000 (504) Cr 2,000 (501) P 3,000 (604) Cr P</p>	<p>ø28,0 x 68,0</p>			<p>1. Tamir + 0,54 + 0,65</p> <p>2. Tamir + 0,65 + 0,77</p> <p>3. Tamir + 0,77 + 0,82</p>
<p>ø80,00</p> <p>4 Cyl. Diesel, 1769 cm³ 44 kW (60 PS) 23:1 8 Ventile XUD7 <u>1985 - 1993</u></p> <p>205 I 1.7 D 205 II 1.7 D 305 II 1.8 D 306 1.8 D BIPPER 1.8 D</p>	<p>18-7550440 STD 18-7550443 0.50 18-7550447 0.80</p>	<p>A = 46,800 B = 84,500 C = 2,000</p>	<p>RE47060000 -STD RE47060050 -0.50 RE47060080 -0.80 RE47060100 -1.00</p> <p>2,000 (500) CrB S 2,000 (501) P 3,000 (604) Cr P</p>	<p>ø25,0 x 69,8</p>	<p>G83001540K_1</p> <p>A= 83,000 B= 80,000 D= 86,000 F= 4,500 H= 0,000 L= 154,000</p> 		



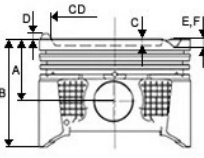
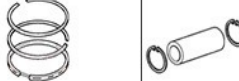



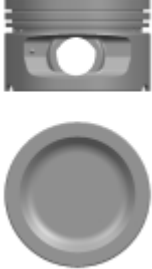
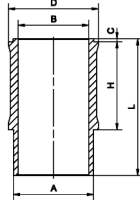

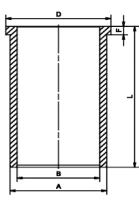
Motor /Engine	Ref. No. Kit 1	Ölçüler /Dimensions	Segman /Rings	Pim	Gömlek /Liner	Kit 2	Info
							
ø82,20 4 Cyl. Diesel 1868 cc 51 Kw (71 Ps) 23:1 DW8 1998 -.... 206 1.9 D 306 1.9 D Expert 1.9 D Partner 1.9 D	18-7550460 STD 18-7550460-20 STD (-0.20 mm) 18-7550463 0.50 18-7550463-20 0.50 (-0.20 mm) 18-7550464 0.60 18-7550464-20 0.60 (-0.20 mm) 18-7550467 0.80 18-7550467-20 0.80 (-0.20 mm) 18-7550468 1.00 18-7550468-20 1.00 (-0.20 mm)	A = 46,730 B = 78,000 C = 1,300 Yag Püskürt. Oyugu (Oil Cut-Out)	RE47430000 -STD RE47430050 -0.50 RE47430060 -0.60 RE47430080 -0.80 RE47430100 -1.00 2,000 (500) CrBS 2,000 (508) P 3,000 (604) Cr	ø25,0 x 66,0	G82201540K_1 A= 85,050 B= 81,500 D= 86,950 F= 5,100 H= 0,000 L= 154,000		1.26 mm conta + 0,51 + 0,55 1.30 mm conta + 0,55 + 0,59 1.34 mm conta + 0,59 + 0,63
ø83,00 4 Cyl. Benzin 1580 cc 9,5:1 XU5 S 2C 1C CP 1982 - 1990 205 Automatic Open XR XS XT 305GL	18-7510180 STD Gömleklı Kodu 19-7510180 STD 18-7510183 0.50 Gömleklı Kodu 19-7510183 0.50	A = 37,500 B = 67,500 C = 2,100	RE47080000 -STD RE47080050 -0.50 RE47080080 -0.80 1,750 (500) CrB S IF 1,750 (508) P 4,000 (700) Cr P S	ø22,0 x 66,0	G88601410S_1 A= 88,540 B= 83,000 D= 97,000 F= 0,000 H= 95,140 L= 141,000		



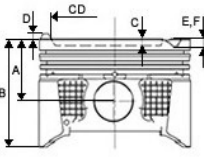





							
Motor /Engine	Ref. No. Kit 1	Ölçüler /Dimensions	Segman /Rings	Pim	Gömlek /Liner	Kit 2	Info
<p>ø83,00</p> <p>4 Cyl. Benzin, 1580 cm³ 59 66 kW (80 90 hp) XU52C CR <u>1982 - 1990</u></p> <p>309 405 1983></p>	<p>18-7510190 STD Gömleklili Kodu 19-7510190 STD</p>	<p>A = 37,500 B = 67,500 C = 2,900</p>	<p>RE47080000 -STD RE47080050 -0.50 RE47080080 -0.80</p> <p>1,750 (500) CrB S IF 1,750 (508) P 4,000 (700) Cr P S</p>	<p>ø22,0 x 66,2</p>	<p>G88601410S_1</p> <p>A= 88,540 B= 83,000 D= 97,000 F= 0,000 H= 95,140 L= 141,000</p>		
<p>ø83,00</p> <p>4 Cyl. Benzin, 1905 cm³ 88 90 kW (120 122 hp) 9,3:1 XU9J2 <u>1987 -....</u></p> <p>309 405</p>	<p>18-7510340 STD Gömleklili Kodu 19-7510340 STD</p>	<p>A = 37,500 B = 67,500</p> <p>Sac Plaka (Steel Support)</p>	<p>RE47090000 -STD RE47090050 -0.50</p> <p>1,500 (500) CrB S IF 1,500 (501) P 4,000 (700) Cr S</p>	<p>ø22,0 x 66,2</p>	<p>G88601410S_1</p> <p>A= 88,540 B= 83,000 D= 97,000 F= 0,000 H= 95,140 L= 141,000</p>		



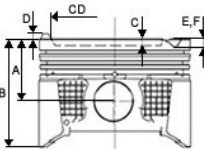



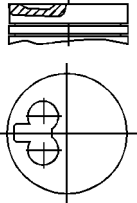

							
Motor /Engine	Ref. No. Kit 1	Ölçüler /Dimensions	Segman /Rings	Pim	Gömlek /Liner	Kit 2	Info
<p>ø83,00</p> <p>4 Cyl. Benzin, 1905 cm³ 73 95 kW (99 129 hp) XU9JA <u>1985 - 1993</u> 205 1,9 GTI 309 1,9</p>	<p>18-7510360 STD Gömleklili Kodu 19-7510360 STD</p>	<p>A = 37,500 B = 67,500 C = 9,000</p>	<p>RE47090000 -STD RE47090050 -0.50</p> <p>1,500 (500) CrB S IF 1,500 (501) P 4,000 (700) Cr S</p>	<p>ø22,0 x 66,2</p>	<p>G88601410S_1</p> <p>A= 88,540 B= 83,000 D= 97,000 F= 0,000 H= 95,140 L= 141,000</p>		
<p>ø83,00</p> <p>4 Cyl. Benzin, 1581 cm³ 53 59 kW (72 80 hp) XU51C XU92C <u>1982 - 1990</u> 309 405</p>	<p>18-7510380 STD Gömleklili Kodu 19-7510380 STD</p>	<p>A = 37,500 B = 67,500 C = 3,000 CD= 73,800</p>	<p>RE47080000 -STD RE47080050 -0.50 RE47080080 -0.80</p> <p>1,750 (500) CrB S IF 1,750 (508) P 4,000 (700) Cr P S</p>	<p>ø22,0 x 66,2</p>	<p>G88601410S_1</p> <p>A= 88,540 B= 83,000 D= 97,000 F= 0,000 H= 95,140 L= 141,000</p>		



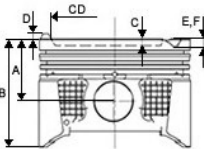





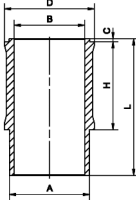
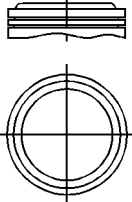
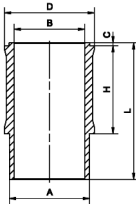



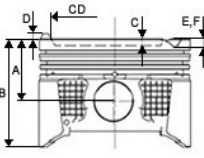





							
Motor /Engine	Ref. No. Kit 1	Ölçüler /Dimensions	Segman /Rings	Pim	Gömlek /Liner	Kit 2	Info
<p>ø83,00</p> <p>4 Cyl. Benzin 1762 cc 74 76 KW/101 103PS 9,25;1 XU7JPZ <u>1992 - 2002</u></p> <p>306 1.8i 405 1.8i 806 1.8i</p>	<p>18-7510400 STD Gömleklili Kodu 19-7510400 STD 18-7510403 0.50 Gömleklili Kodu 19-7510403 0.50</p> 	<p>A = 33,300 B = 53,300 C = 4,200 CD= 67,700</p> <p>Sac Plaka (Steel Support)</p>	<p>RE47100000 -STD RE47100050 -0.50 RE47100080 -0.80</p> <p>1,500 (500) CrB Fe S IF 1,500 (501) P 3,000 (700) Cr P S</p>	<p>ø22,0 x 62,0</p>	<p>G88601410S_1</p> <p>A= 88,540 B= 83,000 D= 97,000 F= 0,000 H= 95,140 L= 141,000</p> 		
<p>ø83,00</p> <p>4 Cyl. Diesel, 1905 cm³ 55 69 kW (75 94 PS) XUD9/A <u>1995 -</u></p> <p>205 II 1.9D 306 1.9D 309 II 1.9D 405 II 1.9D Boxer 1.9D Partner 1.9D</p>	<p>18-7550450 STD 18-7550453 0.50 18-7550458 1.00</p> 	<p>A = 46,800 B = 84,300 C = 2,200</p>	<p>RE47070000 -STD RE47070050 -0.50 RE47070060 -0.60 RE47070080 -0.80 RE47070100 -1.00</p> <p>2,000 (500) CrB S 2,000 (501) P 3,000 (604) Cr P</p>	<p>ø25,0 x 72,0</p>	<p>G86001535K_1</p> <p>A= 86,000 B= 83,000 D= 89,000 F= 5,000 H= 0,000 L= 153,500</p> 		



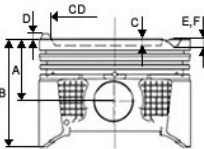





							
Motor /Engine	Ref. No. Kit 1	Ölçüler /Dimensions	Segman /Rings	Pim	Gömlek /Liner	Kit 2	Info
<p>ø83,00</p> <p>4 Cyl. Diesel 1905 cc 51 Kw (69 Ps) 23,5:1 XUD9/A/L/Y <u>1996 -....</u></p> <p>205D GLD /GRD/XLD/XRD 305D/GLD/GRD/SRD Utilitaire 306/309D GLD/GRD/GTD/SRD XD1/XRD/X 405GLD/GRD/J5 Boxer Expert Partner</p>	<p>18-7550480 STD 18-7550483 0.50 18-7550488 1.00</p>	<p>A = 46,850 B = 84,250 C = 2,200</p> <p>Segman Taşıyıcı (Ring Carrier)</p>	<p>RE47070000 -STD RE47070050 -0.50 RE47070060 -0.60 RE47070080 -0.80 RE47070100 -1.00</p> <p>2,000 (500) CrB S 2,000 (501) P 3,000 (604) Cr P</p>	<p>ø25,0 x 70,4</p>			
<p>ø83,00</p> <p>4 Cyl. Benzin 1905 cc 9,3:1 8v MPi XU9JA J1 J2 JAZ M <u>1986 - 1998</u></p> <p>19 Evasion XU9J1 (D6A) XUPJ2 (DFZ) 19 RI XU9J1 (D6A) XUPJ2 (DFZ) 19 RI XU9JA (DDZ-DKZ) 19 TRI XU9JA (DDZ-DKZ) 19GTI XU9J1 (D6A) XUPJ2 (DFZ) 19GTI XU9JA (DDZ-DKZ) 19TRI XU9J1 (D6A) XUPJ2 (DFZ) BX 19 4W</p>	<p>18-7550490 STD</p>	<p>A = 37,500 B = 67,500 C = 8,900</p> <p>Sac Plaka (Steel Support)</p>	<p>RE47090000 -STD RE47090050 -0.50</p> <p>1,500 (500) CrB S IF 1,500 (501) P 4,000 (700) Cr S</p>	<p>ø22,0 x 66,2</p>			



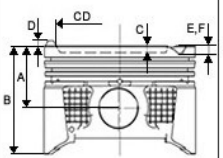





							
Motor /Engine	Ref. No. Kit 1	Ölçüler /Dimensions	Segman /Rings	Pim	Gömlek /Liner	Kit 2	Info
<p>ø83,00</p> <p>4 Cyl. Diesel, 1905 cm³ 55 69 kW (75 94 PS) XUD9ATF XUD9BSD XUD9BTF <u>1993 - 2004</u></p> <p>306 1.9 TD 405 1.9 TD 406 1.9 TD 806 1.9 TD Boxer 1.9 TD Ducato 1.9 TD</p> 	<p>18-7550910 STD 18-7550913 0.50 18-7550917 0.80</p>	<p>A = 46,750 B = 79,250 C = 3,500</p> <p>Sert Anotlama (Hard Anodising)</p>	<p>RE22250000 -STD RE22250050 -0.50 RE22250080 -0.80</p> <p>3,000 (504) Cr P 2,000 (501) P 3,000 (604) Cr P</p>	<p>ø28,0 x 68,0</p>			
<p>ø83,00</p> <p>4 Cyl. Diesel, 1905 cm³ 55 69 kW (75 94 PS) XUD9ATF XUD9BSD XUD9 BTF <u>1992 - 2004</u></p> <p>306 1.9 TD 405 1.9 TD 406 1.9 TD 806 1.9 TD Boxer 1.9 TD Ducato 1.9 TD</p>	<p>18-7550920 STD 18-7550923 0.50</p>	<p>A = 46,750 B = 79,250 C = 3,500</p> <p>Segman Taşıyıcı (Ring Carrier)</p> <p>Sert Anotlama (Hard Anodising)</p> <p>Yag Püskürt. Oyugu (Oil Cut-Out)</p>	<p>RE47230000 -STD RE47230050 -0.50 RE47230080 -0.80</p> <p>3,500 (504) Cr 2,000 (501) P 3,000 (604) Cr P</p>	<p>ø28,0 x 68,0</p>			



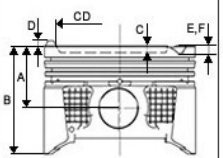







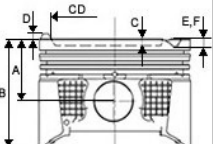

							
Motor /Engine	Ref. No. Kit 1	Ölçüler /Dimensions	Segman /Rings	Pim	Gömlek /Liner	Kit 2	Info
<p>ø84,00</p> <p>4 Cyl. Benzin 1796cc 49 51kW(69 PS) 7,5:1,8 Ventile C25 1.8 169 (XM7T) <u>07/87-02/94</u></p> <p><i>C25 1.8 E C25 1.8 E7/87-2/94 DUCATO 1.8 1/82-10/88 504 1.8 1/71-12/89 505 1.8 6/81-10/85 15 1.8 1/83-11/88 7/70-3/80</i></p>	<p>18-7510020 STD Gömleklili Kodu 19-7510020 STD</p>	<p>A = 37,800 B = 70,250</p>	<p>RE22280000 -STD</p> <p>1,500 (500) Cr S IF 2,000 (508) P 4,000 (700) Cr P S</p>	<p>ø23,0 x 70,0</p>	<p>G93001362S_1</p> <p>A= 93,000 B= 84,000 D= 99,200 F= 0,000 H= 90,000 L= 136,200</p> 		
<p>ø84,00</p> <p>4 Cyl. Benzin, 1796 cm³ 48 58 kW (65 79 hp) 7,5:1 XM7 KF5 KF6 <u>1971 - 1981</u></p> <p><i>504 505 J7 J9 1986></i></p>	<p>18-7510030 STD Gömleklili Kodu 19-7510030 STD</p> 	<p>A = 37,300 B = 70,300 D = 1,000</p>	<p>RE47120000 -STD</p> <p>1,500 (500) Cr S IF 25,000 (508) P 4,000 (700) Cr P S</p>	<p>ø23,0 x 70,0</p>	<p>G93001362S_1</p> <p>A= 93,000 B= 84,000 D= 99,200 F= 0,000 H= 90,000 L= 136,200</p> 		









							
Motor /Engine	Ref. No. Kit 1	Ölçüler /Dimensions	Segman /Rings	Pim	Gömlek /Liner	Kit 2	Info
<p>ø85,00</p> <p>4/6 Cyl. Diesel 2179 cc 110 KW 211 PS DW12BTED4 <u>2011 - 2013</u> FREELANDER 2 2.2 TD4</p>	<p>17-6592300 STD 17-6592303 0.50</p>	<p>A = 48,705 B = 74,705 C = 13,475 E = -0,385 CD= 52,400</p> <p>Segman Taşıyıcı (Ring Carrier)</p> <p>Yag Galerisi (Oil Gallery)</p> <p>Yag Püskürt. Oyugu (Oil Cut-Out)</p>	<p>RE35000000 -STD RE35000050 -0.50</p> <p>2,500 (505) Cr P 2,000 (501) P IFU 2,000 (604) Nit S</p>	<p>ø30,0 x 68,0</p>			
<p>ø85,00</p> <p>4 Cyl. Benzin 2000 cc 100/105 kW 136/1436 PS EW10J B-..... 307 206 EXPEERT 407 607 406 806</p>	<p>18-7510750 STD 18-7510752 0.40 18-7510754 0.60</p>	<p>A = 29,000 B = 51,000 C = 0,750 CD= 48,000</p>	<p>RE18500000 -STD RE18500040 -0.40 RE18500050 -0.50 RE18500060 -0.60 RE18500080 -0.80</p> <p>1,200 (500) Nit S IF 1,500 (508) P 2,500 (700) Nit S</p>	<p>ø21,0 x 68,0</p>			



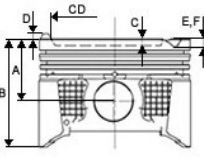





							
Motor /Engine	Ref. No. Kit 1	Ölçüler /Dimensions	Segman /Rings	Pim	Gömlek /Liner	Kit 2	Info
<p>ø85,00</p> <p>4 Cyl. Diesel 1997 cc 103 kW 140PS EW10A RFJ <u>2004 -</u></p> <p>307 308 407 2,0 16V</p>	<p>18-7510760 STD 18-7510763 0.50</p>	<p>A = 29,000 B = 51,150 D = 0,150 E = -3,700</p>	<p>RE18500000 -STD RE18500040 -0.40 RE18500050 -0.50 RE18500060 -0.60 RE18500080 -0.80</p> <p>1,200 (500) Nit S IF 1,500 (508) P 2,500 (700) Nit S</p>	<p>ø21,0 x 56,0</p>			
<p>ø85,00</p> <p>4 Cyl. Diesel 2088 cc 81 Kw (110 Ps) 21,5:1 XUD11BTE <u>1995 -....</u></p> <p>406 2.1TD 605 2.1TD 806 2.1TD</p>	<p>18-7550880 STD 18-7550884 0.60</p>	<p>A = 44,900 B = 74,700 C = 2,400</p> <p>Segman Taşıyıcı (Ring Carrier)</p> <p>Sert Anotlama (Hard Anodising)</p> <p>Yag Galerisi (Oil Gallery)</p> <p>Yag Püskürt. Oyugu (Oil Cut-Out)</p>	<p>RE47240000 -STD RE47240050 -0.50 RE47240060 -0.60</p> <p>3,000 (504) Cr P 2,000 (501) P 3,000 (604) Cr P</p>	<p>ø30,0 x 68,0</p>			<p>1.52 mm conta 0,65 0,75</p> <p>1.57 mm conta 0,77 0,81</p> <p>1.62 mm conta 0,82 0,86</p>



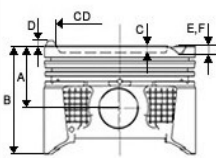



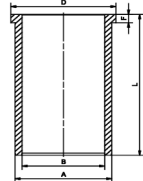
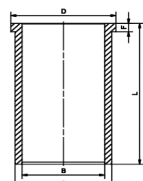

Motor /Engine	Ref. No. Kit 1	Ölçüler /Dimensions	Segman /Rings	Pim	Gömlek /Liner	Kit 2	Info
							
ø85,00 Turbo Intercooler 3 Valf DW12TD/TED 2002 -..... 607 HDI 406 HDI Boxer 330M/330C/290C 2,2 HDI	18-7550890 STD 18-7550894 0.60	A = 48,700 B = 77,700 C = 17,700 E = -1,200 CD= 42,000 Segman Taşıyıcı (Ring Carrier) Yag Püskürt. Oyugu (Oil Cut-Out)	RE47440000 -STD RE47440060 -0.60 3,500 (505) Cr P 2,000 (501) P IFU 3,000 (604) Cr P	ø30,0 x 68,0			
ø85,00 4 Cyl. Diesel 1997/1998 cc 79/80/81/100Kw 90/107/109Ps 110/136 Ps DW10ATED TD10ATED DW10TD Euro 3 G6DB RHS RHW RHX RHY RHZ D420 4T 1998 - 2,0 HDI 206/306/307/406 Boxer Partner Expet C5 Jumpy Xsara Scudo 2.0JTD Cmax Focus II Grand Vitara C30 C70 S40/80 II V50 V70 III TDI	18-7550900 STD 18-7550900-20 STD (-0.20 mm) 18-7550900-40 STD (-0.40 mm) 18-7550903 0.50 18-7550904 0.60	A = 46,750 B = 80,750 C = 18,300 E = -1,000 CD= 38,000 Segman Taşıyıcı (Ring Carrier) Yag Püskürt. Oyugu (Oil Cut-Out)	RE47440000 -STD RE47440060 -0.60 3,500 (505) Cr P 2,000 (501) P IFU 3,000 (604) Cr P	ø28,0 x 70,0			1,25 mm conta +0,55 + 0,60 1,30 mm conta +0,61 +0,65 1,35 mm conta +0,66 +0,70 1,40 mm conta +0,71 +0,75



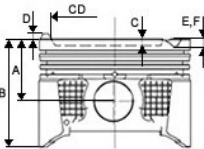



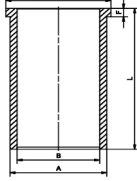
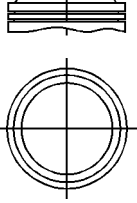
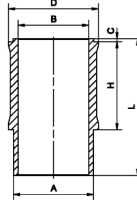

Motor /Engine	Ref. No. Kit 1	Ölçüler /Dimensions	Segman /Rings	Pim	Gömlek /Liner	Kit 2	Info
							
ø85,00 4 Cyl. Diesel, 1997 cm ³ 62 88 kW (84 120 PS) DW10BTED4 1999 - 2007 (2.0HDI) Berlingo C4 16V C4 GrandPicasso 16V C4 Picasso 16V C5 16V C8 16V Jumpy 6V C-Max Kuga 307 16V 307 CC 16V 308 16V 407 16V 508	18-7551920 STD 18-7551924 0.60	A = 46,705 B = 80,705 C = 15,400 E = -0,520 CD= 44,800 Segman Taşıyıcı (Ring Carrier) Yag Galerisi (Oil Gallery) Yag Püskürt. Oyugu (Oil Cut-Out)	RE47440000 -STD RE47440060 -0.60 3,500 (505) Cr P 2,000 (501) P IFU 3,000 (604) Cr P	ø28,0 x 70,0			
ø85,00 4 Cyl. Diesel 1997 cc 163PS DW10CTED4 2009 - 3008 5008 C4 C5 III 2.0 HDI DS4 KUGA	18-7592960 STD 18-7592964 0.60	A = 46,705 B = 74,705 C = 13,710 E = -0,455 CD= 50,400 Segman Taşıyıcı (Ring Carrier) Yag Galerisi (Oil Gallery) Yag Püskürt. Oyugu (Oil Cut-Out)	RE47770000 -STD RE47770060 -0.60 2,000 () 2,000 () P 2,000 ()	ø30,0 x 68,0			



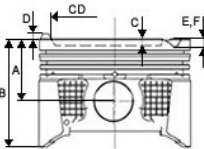



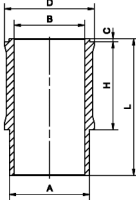

Motor /Engine	Ref. No. Kit 1	Ölçüler /Dimensions	Segman /Rings	Pim	Gömlek /Liner	Kit 2	Info
       							
ø85,00 4 Cyl. Diesel 1997 cc 81/88/100/110 130/132133 KW 110/120/136/150 179/181 PS AHH/J/M/NP/T/U/X EHS/T/W/Y/Z D20 DTH/L/R DW10FC/E/UE/UD/CD FDCC/CU/DDU Euro 5 2009 - 5008/508/508 SW 2.0 Hdi 136 BlueHdi 136/180/150 3008/Blue 2.0 Hdi 150 5008/Blue 2.0 Hdi 150	18-7592970 STD 18-7592974 0.60	A = 46,600 B = 72,000 C = 12,710 CD= 51,300 Segman Taşıyıcı (Ring Carrier) Yag Galerisi (Oil Gallery)	RE47770000 -STD RE47770060 -0.60 2,000 () 2,000 () P 2,000 ()	ø30,0 x 68,0			
 							
ø86,00 4 Cyl. Benzin 1998 cc 88 Kw (121 Ps) XU10J2 XU10J2 TE XU 10J2 Z 1993 - Dizel 2446 cc Boxer 2,5 D 1996	18-7510860 STD 18-7510863 0.50 18-7510864 0.60	A = 40,000 B = 64,850 C = 5,000	RE47130000 -STD RE47130025 -0.25 RE47130050 -0.50 RE47130060 -0.60 1,500 (500) CrB S 1,750 (508) P 3,000 (700) Cr P S	ø22,0 x 62,0			
 							



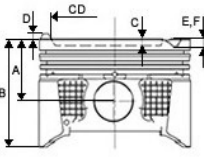





							
Motor /Engine	Ref. No. Kit 1	Ölçüler /Dimensions	Segman /Rings	Pim	Gömlek /Liner	Kit 2	Info
<p>ø86,00</p> <p>4 Cyl. Benzin, 1998 cm³ 98 kW (133 hp) XU10J4R <u>1995 -....</u></p> <p>206 306 307 406 Boxer Partner</p>	<p>18-7510870 STD 18-7510873 0.50 18-7510874 0.60</p>	<p>A = 33,800 B = 53,800 C = 4,300 E = -1,700 F = -2,000 CD= 52,000</p> <p>Yag Püskürt. Oyugu (Oil Cut-Out)</p>	<p>RE47130000 -STD RE47130025 -0.25 RE47130050 -0.50 RE47130060 -0.60</p> <p>1,500 (500) Cr B S 1,750 (508) P 3,000 (700) Cr P S</p>	<p>ø22,0 x 62,0</p>			
<p>ø86,00</p> <p>4 Benzin, 1998 cm³ 120 kW (163 PS) 10:1 16 Ventile RFS (XU10J4RS) <u>05/1996 - 03/2005</u></p> <p>XSARA 2.0 I ZSARA 2.0 16 ZX 2.0 I</p>	<p>18-7510900 STD 18-7510904 0.60</p>	<p>A = 33,900 B = 58,400 C = 2,000 E = -1,740 F = -1,350 CD= 71,920</p> <p>Yag Püskürt. Oyugu (Oil Cut-Out)</p>	<p>RE43190000 -STD RE43190050 -0.50 RE43190100 -1.00</p> <p>1,500 (500) Cr B S 1,500 (501) P 3,000 (700) Cr P S</p>	<p>ø22,0 x 62,0</p>			



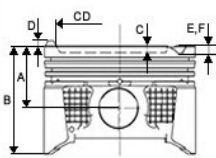





Motor /Engine	Ref. No. Kit 1	Ölçüler /Dimensions	Segman /Rings	Pim	Gömlek /Liner	Kit 2	Info
							
ø86,01 4 Cyl. Diesel 2198/2200 cc 100/120/130/150 Ps 17,5:1 QWFB/V347 Duratorq Euro 4 Duratorq/V347 D CD132 Duratorq TDCI 2003/2008.. Common Rail Transit 2.2 TDCI Yeni Jumper 2.2 HDI Ducato 100 Multijet Yeni Boxer HDI Mondeo 2.2 TDCI Transit 2.2 TDCI	18-2582350 STD 18-2582350-20 STD (-0.20 mm) 18-2582351 0.25 18-2582353 0.50 18-2582353-20 0.50 (-0.20 mm)	A = 43,420 B = 69,820 C = 15,850 CD= 46,900 Segman Taşıyıcı (Ring Carrier) Yag Galerisi (Oil Gallery)	RE23350000 -STD RE23350025 -0.25 RE23350050 -0.50 2,000 (500) Cr P IF 2,000 (508) P 2,000 (604) Nit S	ø30,0 x 66,9	G86011560K_1 A= 89,000 B= 85,310 D= 90,500 F= 5,000 H= 0,000 L= 156,000 		1,10 mm conta +0,38 +0,47 1,20 mm conta +0,48 +0,58 1,30 mm conta + 0,59 +0,68
ø86,01 4 Cyl. Diesel 2198/2179 cc 155 PS 74 Kw (100 Ps) 15,5:1 2.2L Duratorq/HDI (CUFF,CUF5,CVR5,UYRG)) 2002 - Euro 5 TRANSIT 2.2 (YENI) Boxer 2.2L	18-2582420 STD 18-2582420-20 STD (-0.20 mm) 18-2582421 0.25 18-2582423 0.50 18-2582423-20 0.50 (-0.20 mm)	A = 48,420 B = 74,820 C = 18,230 CD= 49,040 Segman Taşıyıcı (Ring Carrier) Yag Galerisi (Oil Gallery) Yag Püskürt. Oyugu (Oil Cut-Out)	RE23350000 -STD RE23350025 -0.25 RE23350050 -0.50 2,000 (500) Cr P IF 2,000 (508) P 2,000 (604) Nit S	ø30,0 x 66,9	G86011650K_1 A= 89,000 B= 85,310 D= 90,500 F= 5,000 H= 0,000 L= 165,000 		



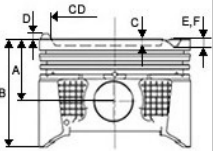





							
Motor /Engine	Ref. No. Kit 1	Ölçüler /Dimensions	Segman /Rings	Pim	Gömlek /Liner	Kit 2	Info
<p>ø86,01</p> <p>4 Cyl. Diesel 2198/2179 cc 155 PS 74 Kw (100 Ps) 15,5:1 2.2L Duratorg/HDI (CUFF,CUF5,CVRS,UYRG)) <u>2002 -</u></p> <p>Euro 5 Boxer 2.2L</p>	<p>18-7592950 STD <i>18-7592950-20 STD (-0.20 mm)</i></p> <p>18-7592951 0.25 18-7592953 0.50 <i>18-7592953-20 0.50 (-0.20 mm)</i></p>	<p>A = 48,420 B = 74,820 C = 18,230 CD= 49,040</p> <p>Segman Taşıyıcı (Ring Carrier)</p> <p>Yag Galerisi (Oil Gallery)</p> <p>Yag Püskürt. Oyugu (Oil Cut-Out)</p>	<p>RE23350000 -STD RE23350025 -0.25 RE23350050 -0.50</p> <p>2,000 (500) Cr P IF 2,000 (508) P 2,000 (604) Nit S</p>	<p>ø30,0 x 66,9</p>	<p>G86011650K_1</p> <p>A= 89,000 B= 85,310 D= 90,500 F= 5,000 H= 0,000 L= 165,000</p> 		
<p>ø88,00</p> <p>4 Cyl. Benzin 1971 cc 57 Kw (78 Ps) XN1P XNA XN1T XN2/3</p> <p><u>1971 - 1993</u></p>	<p>18-7510200 STD Gömleklı Kodu 19-7510200 STD</p> <p>18-7510203 0.50 Gömleklı Kodu 19-7510203 0.50</p> 	<p>A = 38,250 B = 71,850 D = 0,650</p>	<p>RE47160000 -STD RE47160050 -0.50</p> <p>1,500 (500) Cr 2,000 (501) 4,000 (700) Cr P S</p>	<p>ø23,0 x 74,1</p>	<p>G93001356S_1</p> <p>A= 93,000 B= 88,000 D= 101,900 F= 0,000 H= 90,000 L= 135,600</p> 		



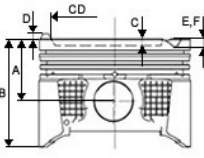







							
Motor /Engine	Ref. No. Kit 1	Ölçüler /Dimensions	Segman /Rings	Pim	Gömlek /Liner	Kit 2	Info
<p>ø88,00</p> <p>4 Cyl. Benzin 1971 cc 57 Kw (78 Ps) XN1T XN1 XN2 <u>1971 - 1993</u></p> <p>J5 J9 504</p>	<p>18-7510220 STD Gömlikli Kodu 19-7510220 STD</p>	<p>A = 37,900 B = 65,450 D = 2,550</p>	<p>RE47160000 -STD RE47160050 -0.50</p> <p>1,500 (500) Cr 2,000 (501) 4,000 (700) Cr P S</p>	<p>ø23,0 x 74,1</p>	<p>G93001356S_1</p> <p>A= 93,000 B= 88,000 D= 101,900 F= 0,000 H= 90,000 L= 135,600</p> 		
<p>ø88,00</p> <p>4 Cyl. Diesel 1975/1987/1990 cc 32/40/42/44 Kw (49/54/5760 Ps) VTA XDP4.88 XD 4.88 XD 88 XD P 4.88/4.88/88 <u>1987</u></p> <p>504 1.9D 404 1.9D 404 2.0D/504 2.0D J 7 1.9 D Granada 2.0D</p>	<p>18-7550930 STD</p>	<p>A = 58,700 B = 95,700 C = 1,950</p>	<p>RE47140000 -STD</p> <p>2,000 (500) Cr 2,000 (501) P 2,000 (508) P 4,500 (604) P</p>	<p>ø28,0 x 72,0</p>			

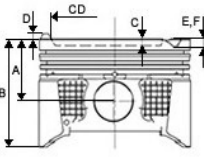







							
Motor /Engine	Ref. No. Kit 1	Ölçüler /Dimensions	Segman /Rings	Pim	Gömlek /Liner	Kit 2	Info
<p>ø92,00</p> <p>4 Cyl. Diesel 2446 cc DJ5 <u>1996 -....</u> Boxer 2,5 D</p>	<p>18-7550530 STD 18-7550533 0.50</p>	<p>A = 49,740 C = 1,750</p>	<p>RE47500000 -STD RE47500050 -0.50</p> <p>2,250 (500) Cr P 2,000 (508) P 3,000 (604) Cr P</p>	<p>ø34,0 x 58,0</p>			<p>+ 0,40 + 0,60</p>
<p>ø92,00</p> <p>4 Cyl. Diesel 2446 cc DJ5TDI TED <u>1997 -....</u> Boxer 2,5 TD</p>	<p>18-7589220 STD 18-7589223 0.50</p>	<p>A = 57,000 B = 89,000 C = 18,250 E = -1,500 CD= 41,000</p> <p>Segman Taşıyıcı (Ring Carrier)</p> <p>Yag Galerisi (Oil Gallery)</p>	<p>RE47520000 -STD RE47520050 -0.50</p> <p>3,500 (505) MoB N 2,000 (508) P 3,500 (604) Cr P</p>	<p>ø34,0 x 68,0</p>			<p>1,30 mm conta + 0,50 + 0,60</p>



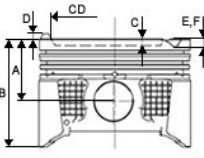



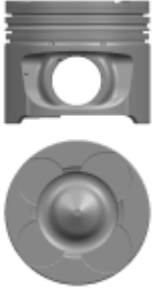

Motor /Engine	Ref. No. Kit 1	Ölçüler /Dimensions	Segman /Rings	Pim	Gömlek /Liner	Kit 2	Info
       							
ø92,00 4 Cyl. 2446 cc 76 96 Kw (103 130 Ps) Turbo DJ5T 1997 -.... Boxer 2,5 T Citroen Jumper 2,5 T	18-7589330 STD 18-7589333 0.50	A = 49,840 C = 2,300 Segman Taşıyıcı (Ring Carrier) Sert Anotlama (Hard Anodising) Yag Galerisi (Oil Gallery)	RE47310000 -STD RE47310050 -0.50 3,000 (504) MoB N IF 1,750 (501) Cr IF 3,500 (604) Cr P	ø34,0 x 68,0			+ 0,64 + 0,74
ø93,03 4 Cyl. Diesel 2498cc 54 kW (73 PS) 4JB1 1981 - 1994 Karsan J9 Premier	18-7550870 STD	A = 51,850 B = 91,850 C = 19,500 E = -0,550 CD= 43,900 Segman Taşıyıcı (Ring Carrier) Sac Plaka (Steel Support) Yag Püskürt. Oyugu (Oil Cut-Out)	RE47420000 -STD RE47420050 -0.50 2,000 (500) Cr P 2,000 (508) P 4,000 (604) Cr P	ø31,0 x 76,0			0 + 0,70

Motor /Engine	Ref. No. Kit 1	Ölçüler /Dimensions	Segman /Rings	Pim	Gömlek /Liner	Kit 2	Info
							
ø94,40 4 Cyl. Diesel 2798 cc 64 Kw (87 Ps) Sofim Motor 8140.63.3700 1998 - 1999 Ducato 14 2.8 D Ducato Maxi 2.8D	18-2051130 STD 18-2051132 0.40 18-2051134 0.60	A = 55,000 B = 90,000 C = 1,700 Segman Taşıyıcı (Ring Carrier) Sert Anotlama (Hard Anodising) Yag Püskürt. Oyugu (Oil Cut-Out)	RE22790000 -STD RE22790040 -0.40 RE22790060 -0.60 3,000 (504) Cr P 2,000 (501) P IWU 2,500 (604) Cr P	ø32,0 x 68,0			+ 0,40 + 0,50 (1.20 mm Conta) + 0,51 + 0,60 (1.30 mm Conta) + 0,61 + 0,70 (1.40 mm Conta)
ø94,40 4 Cyl. Diesel 2798 cc 107 Kw (146 Ps) 18 5:1 SOFIM 8140.43S.4000 Euro 3 8140.23.2585/3700 Euro 3 8140.63.3700 8140.43M. 4300/4320/4330 Euro 3 2000-.... Ducato 2.8 JTD 35C.15/35S.15/50C.15 60C.15 TD/65C.15 65C.13 Daily Unijet Boxer 2.8 HDI	18-2081440 STD 18-2081440-20 STD (-0.20 mm) 18-2081442 0.40 18-2081442-20 0.40 (-0.20 mm) 18-2081444 0.60 18-2081444-20 0.60 (-0.20 mm)	A = 58,700 B = 87,600 C = 21,300 CD= 39,500 Segman Taşıyıcı (Ring Carrier) Yag Galerisi (Oil Gallery) Yag Püskürt. Oyugu (Oil Cut-Out)	RE22780000 -STD RE22780040 -0.40 RE22780060 -0.60 2,500 (504) Cr P 2,000 (501) P 2,500 (604) Cr P	ø32,0 x 72,0			1,20 mm conta + 0,40 + 0,50 1,30 mm conta + 0,51 + 0,60 1,40 mm conta + 0,61 + 0,70 1,50 mm conta + 0,71 + 0,80

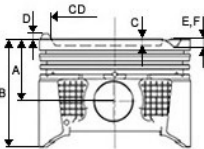







							
Motor /Engine	Ref. No. Kit 1	Ölçüler /Dimensions	Segman /Rings	Pim	Gömlek /Liner	Kit 2	Info
<p>ø95,80</p> <p>4 Cyl.Diesel 2998 cc 156 PS18:01 T3.0 F1C/HDI EURO 5</p> <p>.... -</p> <p>JUMPER</p>	<p>18-2092980 STD</p> <p>18-2092982 0.40</p>	<p>A = 63,000</p> <p>B = 93,400</p> <p>C = 16,000</p> <p>CD= 53,200</p> <p>Segman Taşıyıcı (Ring Carrier)</p> <p>Yag Galerisi (Oil Gallery)</p> <p>Yag Püskürt. Oyugu (Oil Cut-Out)</p>	<p>RE22870000 -STD</p> <p>RE22870040 -0.40</p> <p>2,500 (504) Cr P</p> <p>2,000 (501) P</p> <p>2,500 (604) P</p>	<p>ø36,0</p> <p>x 80,8</p>			



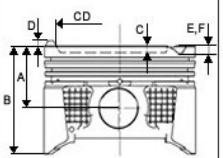



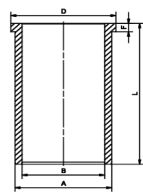
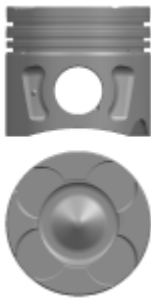

							
Motor /Engine	Ref. No. Kit 1	Ölçüler /Dimensions	Segman /Rings	Pim	Gömlek /Liner	Kit 2	Info
<p>ø92,00</p> <p>4 Cyl. Diesel 2500 cc 2085G DODGE NITRO <u>1999-2001</u> 2,5 HP-DODGE NITRO</p>	<p>18-9792110 STD 18-9792113 0.50</p>	<p>A = 52,000 B = 80,000 C = 17,000 E = -1,000 F = -1,000 CD= 52,200</p> <p>Segman Taşıyıcı (Ring Carrier)</p> <p>Yag Galerisi (Oil Gallery)</p>		<p>ø25,0 x 68,0</p>			
<p>ø93,00</p> <p>8 Cyl. Benzin 4700 cc</p> <p>CPW6925 8V 4.7LT Power Tech V8 <u>1999 - 2007</u></p> <p>Dakota (AN) 2000/2007 Durango (DN) 2000/2007 Commander (XK/XH) 2006/2007 Grand Cherokee (WJ/WG/WK/WH) 1999-2007 Ram1500 Pickup 2002/2007 Raider 2006/2007</p>	<p>17-9710320 STD 17-9710323 0.50</p>	<p>A = 31,800 B = 53,800</p>	<p>RK97109300010 -STD RK97109300013 -0.50</p> <p>1,500 () GI 1,500 () Cr 3,000 () Cr</p>	<p>ø24,0 x 59,0</p>			
 							



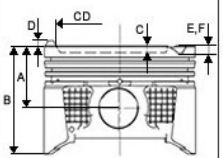



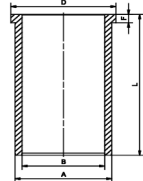
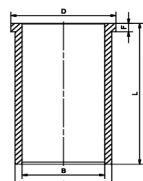

							
Motor /Engine	Ref. No. Kit 1	Ölçüler /Dimensions	Segman /Rings	Pim	Gömlek /Liner	Kit 2	Info
<p>ø94,00</p> <p>4 Cyl. Diesel 2800 cc 180 ps 2.8 HP DODGE NITRO</p> <p>2.8 HP DODGE NITRO 2007/2008 GRAND KARAVAN IV 2008-2010 JEEP LIBERTE/CHEROKEE (KK) 2008-2009 CHEROKEE WRANGLER (JK) 2007-... CHRYSLER VOYAGER/VILLE&PAYS 2008-2010</p>	<p>18-9792010 STD 18-9792013 0.50</p>	<p>A = 52,000 B = 80,000 C = 17,000 E = -1,000 F = -1,000 CD= 52,200</p> <p>Segman Taşıyıcı (Ring Carrier)</p> <p>Yag Galerisi (Oil Gallery)</p>	<p>RE04000000 -STD RE04000050 -0.50</p> <p>2,500 (500) Cr P 1,500 (501) P 2,000 (2)G GN</p>	<p>ø32,0 x 74,0</p>			
							



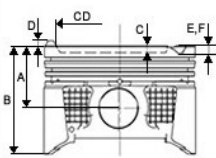



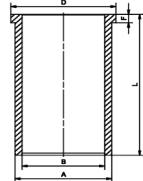
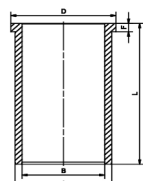

							
Motor /Engine	Ref. No. Kit 1	Ölçüler /Dimensions	Segman /Rings	Pim	Gömlek /Liner	Kit 2	Info
<p>ø65,00</p> <p>4 Cyl. Benzin 903/899cc 30/29kw 41/39 PS 170 A1.000 170 A1.046 1170 A1.046 <u>0492-1296</u></p> <p><i>Panda 900 (04/92-12/96) Secento/600 0.9 (01/98-01/10) Cinquecento 0.9/i.e (07/91-12/93) Cinquecento 0.9 i.e.S (07/91-07/99)</i></p>	<p>18-2010530 STD 18-2010532 0.40 18-2010534 0.60</p>	<p>A = 31,250 B = 54,250</p>	<p>RE22000000 -STD RE22000040 -0.40 RE22000060 -0.60</p> <p>1,500 (500) CrvS IF 1,500 (508) P 3,000 (700) Cr P S</p>	<p>ø22,0 x 58,2</p>			
<p>ø65,00</p> <p>4 Cyl. Benzin 903 cm³ 33 kW (45 hp) 9:1 146 A.000 <u>1984-1989</u></p> <p><i>Panda I 900 Uno 45 127 Fiorino</i></p>	<p>18-2010540 STD 18-2010542 0.40 18-2010544 0.60</p>	<p>A = 31,250 B = 61,750</p>	<p>RE22010000 -STD RE22010025 -0.25 RE22010040 -0.40 RE22010060 -0.60 RE22010080 -0.80 RE22010100 -1.00</p> <p>1,750 (500) CrBFes IF 2,000 (508) P 3,947 (700) Cr P S</p>	<p>ø20,0 x 54,0</p>			



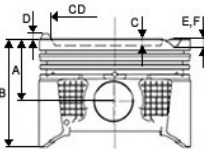









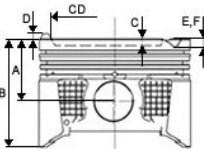



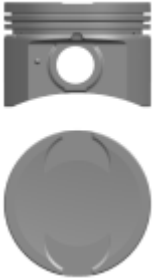

Motor /Engine	Ref. No. Kit 1	Ölçüler /Dimensions	Segman /Rings	Pim	Gömlek /Liner	Kit 2	Info
							
ø65,00 4 Cyl. Benzin 903 cm ³ 38 kW (52 hp) 100.G.000 100.GB.000 100.GC.000 100.GF.000 100.GL. 1968-1973 Panda/900 Uno 127 Fiorino	18-2010550 STD 18-2010551 0.25 18-2010552 0.40 18-2010554 0.60 18-2010557 0.80 18-2010558 1.00	A = 30,750 B = 61,950 D = 0,700	RE22010000 -STD RE22010025 -0.25 RE22010040 -0.40 RE22010060 -0.60 RE22010080 -0.80 RE22010100 -1.00 1,750 (500) CrFeS IF 2,000 (508) P 3,947 (700) Cr P S	ø20,0 x 54,0			
	ø69,60 4 Cyl. Diesel 1248cc 75 HP/95 70Kw 16,8:1 1.3 75Hp Multi.jet II 16v Euro 5 95 PS A 13DTE 2009 - 1.3 CDTI (Astra J Corsa D Meriva) 1.3 D Multijet MITO STRADA Pick-up PANDA FIORINO Kasten/Kombi QUBO IDEA PUNTO Van AVEO Schrägheck(Euro-4)1	18-2092250 STD 18-2092250-20 STD (-0.20 mm) 18-2092250-40 STD (-0.40 mm) 18-2092252 0.40 18-2092252-20 0.40 (-0.20 mm) 18-2092252-40 0.40 (-0.40 mm) 18-2092254 0.60 18-2092254-20 0.60 (-0.20 mm) 18-2092257 0.80 18-2092257-20 0.80 (-0.20 mm) 18-2092257-40 0.80 (-0.40 mm)	A = 40,430 B = 62,430 C = 12,700 E = -1,153 F = -0,904 CD= 37,000 Segman Taşıyıcı (Ring Carrier) Yag Galerisi (Oil Gallery) Yag Püskürt. Oyugu (Oil Cut-Out)	RE22860000 -STD RE22860040 -0.40 RE22860060 -0.60 RE22860080 -0.80 RE22860100 -1.00 1,500 (500) Cr P 1,500 (501) P 2,000 (604) Nit S	ø23,0 x 56,7	G69601420K_1 A= 72,500 B= 68,900 D= 74,000 F= 5,000 H= 0,000 L= 142,000 	0,67 0,77 mm Conta Yle + 0,028 + 0,127 0,77 0,87 mm Conta +0,127 +0,227 0,87 0,97 mm Conta + 0,228 + 0,327
							



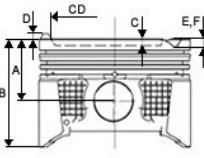



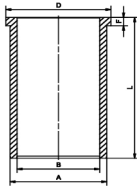
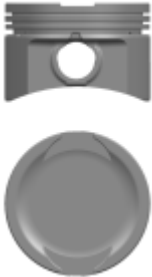
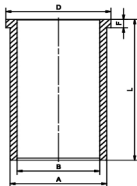

Motor /Engine	Ref. No. Kit 1	Ölçüler /Dimensions	Segman /Rings	Pim	Gömlek /Liner	Kit 2	Info
							
ø69,60 4 Cyl. Diesel 1248cc 75 HP 55/70 KW 75/95 PS B13 DTE/DTR 1.3 CDTi (EUR 6) 2006 - 1.3 CDTi CORSA E Van (X15) CORSA E (X15) CORSAVAN Mk III (D) (S07) CORSAVAN MkIV E (X15) CORSAVAN Mk IV-€ (X15) MITO	18-2092260 STD 18-2092260-20 STD (-0.20 mm) 18-2092260-40 STD (-0.40 mm) 18-2092262 0.40 18-2092262-20 0.40 (-0.20 mm) 18-2092262-40 0.40 (-0.40 mm) 18-2092267 0.80 18-2092267-20 0.80 (-0.20 mm) 18-2092267-40 0.80 (-0.40 mm)	A = 40,430 B = 62,430 C = 12,000 CD= 42,300 Segman Taşıyıcı (Ring Carrier) Yag Galerisi (Oil Gallery) Yag Püskürt. Oyugu (Oil Cut-Out)	RE22860000 -STD RE22860040 -0.40 RE22860060 -0.60 RE22860080 -0.80 RE22860100 -1.00 1,500 (500) Cr P 1,500 (501) P 2,000 (604) Nit S	ø23,0 x 56,7	G69601420K_1 A= 72,500 B= 68,900 D= 74,000 F= 5,000 H= 0,000 L= 142,000 		
ø69,60 4 Cyl. Diesel 1248cc 90 HP 1.3 90HP MULTIJET II 1.6V EURO 5 2009 - Stop/Start Motorlara Ait DOBLO CARGO PRATICO	18-2092320 STD 18-2092320-20 STD (-0.20 mm) 18-2092320-40 STD (-0.40 mm) 18-2092322 0.40 18-2092322-20 0.40 (-0.20 mm) 18-2092322-40 0.40 (-0.40 mm) 18-2092324 0.60 18-2092324-20 0.60 (-0.20 mm) 18-2092327 0.80 18-2092327-20 0.80 (-0.20 mm) 18-2092327-40 0.80 (-0.40 mm)	A = 40,300 B = 62,430 C = 12,700 E = -1,153 F = -0,904 CD= 37,000 Segman Taşıyıcı (Ring Carrier) Yag Galerisi (Oil Gallery) Yag Püskürt. Oyugu (Oil Cut-Out)	RE22860000 -STD RE22860040 -0.40 RE22860060 -0.60 RE22860080 -0.80 RE22860100 -1.00 1,500 (500) Cr P 1,500 (501) P 2,000 (604) Nit S	ø23,0 x 56,7	G69601420K_1 A= 72,500 B= 68,900 D= 74,000 F= 5,000 H= 0,000 L= 142,000 	0,67 0,77 mm Conta + 0,028 + 0,127 0,77 0,87 mm Conta +0,127 +0,227 0,87 0,97 mm Conta + 0,228 + 0,327	

Motor /Engine	Ref. No. Kit 1	Ölçüler /Dimensions	Segman /Rings	Pim	Gömlek /Liner	Kit 2	Info
							
ø69,60 4 Cyl. Diesel 1248 cc 70 Ps 18:1 Turbo, Common Rail 16v 188 A8.000 Euro 4 188 A9.000 Euro 4 199 A2.000 Eur <u>2003 -....</u> Agila 1.3 Corsa 1.3 Meriva 1.3 Tigra 1.3 Albea 1.3 Multijet Doblo 1.3 Multijet Palio 1.3 Multijet Suzuki 1.3 Multijet	18-3050230 STD 18-3050230-20 STD (-0.20 mm) 18-3050230-40 STD (-0.40 mm) 18-3050232 0.40 18-3050232-20 0.40 (-0.20 mm) 18-3050232-40 0.40 (-0.40 mm) 18-3050234 0.60 18-3050234-20 0.60 (-0.20 mm) 18-3050234-40 0.60 (-0.40 mm) 18-3050237 0.80 18-3050237-20 0.80 (-0.20 mm) 18-3050237-40 0.80 (-0.40 mm)	A = 40,430 B = 63,430 C = 12,400 E = -1,000 CD= 38,000 Segman Taşıyıcı (Ring Carrier) Yag Püskürt. Oyugu (Oil Cut-Out)	RE22030000 -STD RE22030040 -0.40 RE22030060 -0.60 RE22030080 -0.80 2,000 (500) Cr P 1,500 (501) P 2,000 (604) Nit S	ø23,0 x 56,7	G69601420K_1 A= 72,500 B= 68,900 D= 74,000 F= 5,000 H= 0,000 L= 142,000		0,67 0,77 mm Conta +0,02 +0,13 0,77 0,87 mm Conta +0,13 +0,23 0,87 0,97 mm Conta +0,23 +0,33
ø69,60 4 Cyl. Diesel 1248 cc 66 Kw (90 Ps) 17,6:1 199A3000 Multijet Euro 5 Z13 DTH A13DTE Euro 5 16V <u>2009 -....</u> ASTRA J CORSA D Grande Punto1.3CDTI 16V Linea Grande Punto	18-3082550 STD 18-3082550-20 STD (-0.20 mm) 18-3082550-40 STD (-0.40 mm) 18-3082552 0.40 18-3082552-20 0.40 (-0.20 mm) 18-3082552-40 0.40 (-0.40 mm) 18-3082554 0.60 18-3082554-20 0.60 (-0.20 mm) 18-3082554-40 0.60 (-0.40 mm) 18-3082557 0.80 18-3082557-20 0.80 (-0.20 mm) 18-3082557-40 0.80 (-0.40 mm)	A = 40,430 B = 62,430 C = 12,400 E = -0,904 F = -1,154 CD= 38,000 Segman Taşıyıcı (Ring Carrier) Yag Galerisi (Oil Gallery) Yag Püskürt. Oyugu (Oil Cut-Out)	RE22030000 -STD RE22030040 -0.40 RE22030060 -0.60 RE22030080 -0.80 2,000 (500) Cr P 1,500 (501) P 2,000 (604) Nit S	ø23,0 x 56,7	G69601420K_1 A= 72,500 B= 68,900 D= 74,000 F= 5,000 H= 0,000 L= 142,000		0,67 0,77 mm Conta +0,028 +0,127 0,77 0,87 mm Conta +0,127 +0,227 0,87 0,97 mm Conta +0,228 +0,327

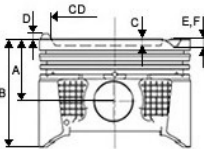





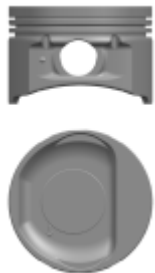

							
Motor /Engine	Ref. No. Kit 1	Ölçüler /Dimensions	Segman /Rings	Pim	Gömlek /Liner	Kit 2	Info
<p>ø70,00</p> <p>4 Cyl. Benzin</p> <p>999 cm³ 33/37 kW (45/50 hp) 9:1 9 8:1 8 Ventile 156 A2/A3.000 M 204 AA/BA 10/0 XO 125</p> <p><u>1985-1995</u></p> <p>Panda 1000 Uno</p>	<p>18-2010140 STD 18-2010142 0.40 18-2010144 0.60</p>	<p>A = 33,900 B = 57,400 C = 0,500 CD= 55,000</p> <p>Sac Plaka (Steel Support)</p>	<p>RE22040000 -STD RE22040040 -0.40 RE22040060 -0.60</p> <p>1,500 (500) CrBFe S IF 1,500 (501) P 3,000 (700) Cr P S</p>	<p>ø18,0 x 53,0</p>			
<p>ø70,00</p> <p>4 Cyl. Benzin</p> <p>1108 cm³ 41 kW (56 hp) 9 6:1 160 A3.000 M 204 AA 11/0</p> <p><u>1988-1993</u></p> <p>Tipo 1,1 Uno 60 Fire</p>	<p>18-2010150 STD 18-2010152 0.40</p>	<p>A = 30,000 B = 53,500 C = 1,800 CD= 60,000</p>	<p>RE22040000 -STD RE22040040 -0.40 RE22040060 -0.60</p> <p>1,500 (500) CrBFe S IF 1,500 (501) P 3,000 (700) Cr P S</p>	<p>ø18,0 x 53,0</p>			



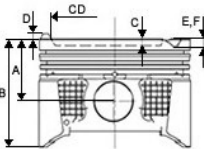





							
Motor /Engine	Ref. No. Kit 1	Ölçüler /Dimensions	Segman /Rings	Pim	Gömlek /Liner	Kit 2	Info
<p>ø70,00</p> <p>4 Cyl. Benzin</p> <p>999 cm³ 32 34 kW (44 46 hp) 156 A2.046 <u>1985-1993</u></p> <p><i>Panda 1000</i> <i>Uno 45</i></p>	<p>18-2010160 STD 18-2010162 0.40</p>	<p>A = 33,900 B = 57,400 C = 1,500 CD= 55,000</p>	<p>RE22040000 -STD RE22040040 -0.40 RE22040060 -0.60</p> <p>1,500 (500) CrBFe S IF 1,500 (501) P 3,000 (700) Cr P S</p>	<p>ø18,0 x 53,0</p>			
<p>ø70,00</p> <p>4 Cyl. Benzin</p> <p>1108 cm³ 37 40 kW (50 54 hp) 176 A6.000 176 B2.000 187 A1.000 <u>1992-....</u></p> <p><i>Panda I 1100</i> <i>Panda II 1.1</i> <i>Punto I 1.1</i></p>	<p>18-2010180 STD 18-2010182 0.40 18-2010184 0.60</p>	<p>A = 30,000 B = 50,000 C = 1,500 E = -0,700 CD= 60,000</p>	<p>RE22640000 -STD RE22640040 -0.40 RE22640060 -0.60</p> <p>1,200 (500) CrB Fe S IF 1,200 (508) P 2,500 (700) Nit S</p>	<p>ø18,0 x 53,0</p>			



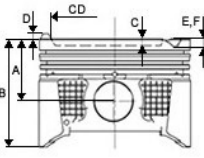





							
Motor /Engine	Ref. No. Kit 1	Ölçüler /Dimensions	Segman /Rings	Pim	Gömlek /Liner	Kit 2	Info
<p>ø70,80</p> <p>4 Cyl. Benzin 1242 cc 59 Kw 80 Ps 188.A5.000 <u>1999 - 2005</u></p> <p><i>Albea 1.2 16v Brava 1.2 16v Bravo 1.2 16v Idea 1.2 16v Palio 1.2 16v Punto 1.2 16v Stilo 1.2 16v</i></p> 	<p>18-2010170 STD 18-2010172 0.40 18-2010174 0.60</p>	<p>A = 28,000 B = 48,000 C = 5,100 E = -2,000</p>	<p>RE22650000 -STD RE22650040 -0.40 RE22650060 -0.60</p> <p>1,200 (500) CrB P S IF 1,200 (501) P 2,500 (700) Cr P S</p>	<p>ø18,0 x 49,0</p>	<p>G73801280K_1</p> <p>A= 73,800 B= 70,800 D= 75,000 F= 5,000 H= 0,000 L= 128,000</p> 		
<p>ø70,80</p> <p>4 Cyl. Benzin 1241 cc 44 Kw (60 Ps) 9 8:1 188.A4.000 <u>2000-....</u></p> <p><i>Albea 1.2 8v Palio 1.2 8v Doblo 1.2 8v Sienna 1.2 8v</i></p> 	<p>18-2010190 STD 18-2010192 0.40 18-2010194 0.60</p>	<p>A = 28,000 B = 48,000 C = 2,000 E = -1,400 CD= 60,500</p>	<p>RE22650000 -STD RE22650040 -0.40 RE22650060 -0.60</p> <p>1,200 (500) CrB P S IF 1,200 (501) P 2,500 (700) Cr P S</p>	<p>ø18,0 x 53,0</p>	<p>G73801280K_1</p> <p>A= 73,800 B= 70,800 D= 75,000 F= 5,000 H= 0,000 L= 128,000</p> 		



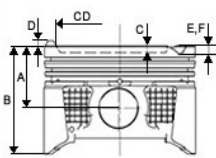



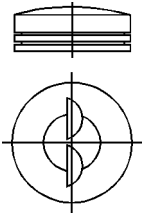

							
Motor /Engine	Ref. No. Kit 1	Ölçüler /Dimensions	Segman /Rings	Pim	Gömlek /Liner	Kit 2	Info
<p>ø70,80</p> <p>4 Benzin, 1242 cc 48kW 65 ps 169A4 199 A4.000</p> <p><u>2005</u></p> <p>Punto EVO 1.2 Grande Punto 1.2i</p>	<p>18-2010200 STD 18-2010202 0.40 18-2010204 0.60</p>	<p>A = 28,600 B = 48,000 C = 3,900</p>	<p>RE22650000 -STD RE22650040 -0.40 RE22650060 -0.60</p> <p>1,200 (500) CrB P S IF 1,200 (501) P 2,500 (700) Cr P S</p>	<p>ø18,0 x 49,0</p>			
<p>ø72,00</p> <p>4 Cyl. Benzin 1368 cc 57 Kw (77 HP) 350.A1.000 Euro 4</p> <p><u>2003-.....</u></p> <p>Albea 1.4 8v Doblo 1.4 8v Idea 1.4 8v Pallo 1.4 8v Grande Punto 1.4 8v</p>	<p>18-2010210 STD 18-2010212 0.40</p>	<p>A = 26,000 B = 49,000 C = 4,750 E = -2,050</p>	<p>RE22050000 -STD RE22050040 -0.40</p> <p>1,000 (500) NitB S IF 1,200 (508) P 2,000 (604) Nit S</p>	<p>ø18,0 x 49,0</p>			



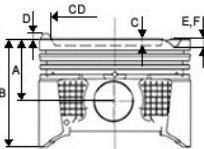





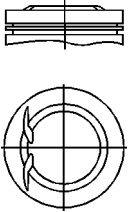
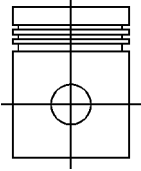



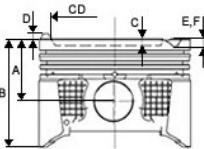



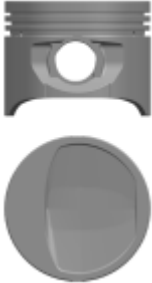

							
Motor /Engine	Ref. No. Kit 1	Ölçüler /Dimensions	Segman /Rings	Pim	Gömlek /Liner	Kit 2	Info
<p>ø72,00</p> <p>4 Cyl. Benzin 1368 cc 57 Kw (77 HP) 843.A1.000 <u>2003-....</u></p> <p>500 L 1.4 16v Doblo 1.4 16v Idea 1.4 16v Punto II 1.4 16v Stilo 1.4 16v</p>	<p>18-2010220 STD 18-2010222 0.40</p>	<p>A = 26,800 B = 49,800 C = 8,000 E = -1,400 F = -2,300 CD= 61,000</p>	<p>RE22811000 -STD RE22811040 -0.40</p> <p>1,200 (500) Cr P 1,200 (508) P 2,000 (700) Cr P S</p>	<p>ø18,0 x 53,0</p>			
<p>ø72,00</p> <p>4 Cyl. Benzin 1368 cc 88/99/103/104 107/110/114/132 kW 120/135/140/141 145/150/155/180 PS 198A1.000 198A4.000 199 A8.000 940 B7.000 955 A2.0000 312 A3.000 Egea 1.4 16Valf</p> <p>.... -....</p> <p>198.A1.000 199.A8/A4.000 312.A3.000 940.B7.000 955.A2.000 Euro 5</p>	<p>18-2010230 STD 18-2010232 0.40</p>	<p>A = 26,800 B = 49,800 C = 5,700 E = -1,800 F = -2,600</p>	<p>RE22811000 -STD RE22811040 -0.40</p> <p>1,200 (500) Cr P 1,200 (508) P 2,000 (700) Cr P S</p>	<p>ø18,0 x 53,0</p>			

							
Motor /Engine	Ref. No. Kit 1	Ölçüler /Dimensions	Segman /Rings	Pim	Gömlek /Liner	Kit 2	Info
<p>ø72,00</p> <p>4 Cyl. Benzin 1396 cc 66 KW 180/90 PS Biyel Kolu Sıkı Geçme 192 B 2000/843 A1000</p> <p><u>2015 -....</u></p> <p>500L BRAVO II 1.4I DOBLO 1.4 EGEA 1.4 IDEA 1.4I PUNTO II 1.4</p>	<p>18-2010240 STD</p> <p>18-2010242 0.40</p>	<p>A = 26,000 B = 49,000 C = 7,800 E = -1,400 F = -2,200 CD= 57,600</p>	<p>RE22051000 -STD RE22051040 -0.40</p> <p>1,000 (500) NitB S IF 1,200 (508) P 2,000 (700) Nit S</p>	<p>ø18,0 x 49,0</p>			
<p>ø76,00</p> <p>4 Cyl. Benzin 1297 cc 41/52 Kw (55/70 Ps) 131 A.000</p> <p><u>1981-....</u></p> <p>Murat 131 Serçe</p>	<p>18-2010260 STD</p> <p>18-2010262 0.40</p>	<p>A = 38,450 B = 77,950 D = 0,500 CD= 45,000</p>	<p>RE22080000 -STD RE22080040 -0.40 RE22080060 -0.60</p> <p>1,500 (500) Cr S 2,000 (508) P 3,947 (700) Cr P S</p>	<p>ø22,0 x 61,0</p>			

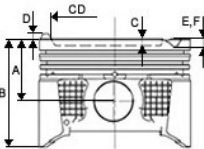





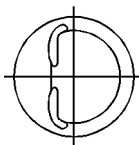
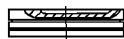

Motor /Engine	Ref. No. Kit 1	Ölçüler /Dimensions	Segman /Rings	Pim	Gömlek /Liner	Kit 2	Info
							
ø79,50 4 Cyl. Diesel 1598 cc 70/74/77 84/85/88 KW 95/100/101 105/114/115 116/120 PS 16:5 1.6 16V Multi.jet (EURO 5) EJJ EJK 198 A2/A3.000 940/955 A3/C1/C5/A4.000 552 60 384/552 63 113 <u>2010 -</u> Bravo 1.6 16v Doblo II 1.6 16V Linea 1.616V FIAT Alfa Romeo Jeep Chrysler Lancia	18-2050040 STD 18-2050042 0.40	A = 43,950 B = 68,950 C = 13,800 E = -0,460 F = -0,600 CD= 41,700 Segman Taşıyıcı (Ring Carrier)	RE22880000 -STD RE22880040 -0.40 RE22880060 -0.60 1,500 (500) CrP 1,500 (508) P 2,000 (604) NitS	ø26,0 x 62,8			Deliksiz conta (0,82 mm) +0,02 +0,10 Tek delik conta (0,92 mm) +0,10 +0,20 İki delik conta +0,20 +0,30
ø80,00 4.Cyl.benzin 1100 cc 128 A.000 128 AC 5.000 138 A.000 <u>12/75 - 01/80</u> 128-138-Uno 55 Ritmo 60	18-2010030 STD 18-2010032 0.40 18-2010034 0.60 18-2010037 0.80 18-2010038 1.00	A = 34,700 B = 77,300 D = 0,600 E = -2,600	RE22130000 -STD RE22130040 -0.40 RE22130060 -0.60 RE22130080 -0.80 RE22130100 -1.00 1,500 (500) CrB Fe S 2,000 (508) P 3,940 (700) Cr P S	ø21,9 x 71,0			
							



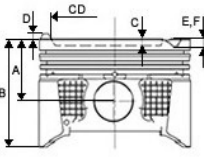





							
Motor /Engine	Ref. No. Kit 1	Ölçüler /Dimensions	Segman /Rings	Pim	Gömlek /Liner	Kit 2	Info
<p>ø80,00</p> <p>4.Cyl.benzin 1100 cc 138 B 1.000 <u>1983...1987</u> Ritmo ES</p> 	<p>18-2010080 STD</p>	<p>A = 35,050 B = 75,150 C = 0,600</p>	<p>RE22130000 -STD RE22130040 -0.40 RE22130060 -0.60 RE22130080 -0.80 RE22130100 -1.00</p> <p>1,500 (500) CrB Fe S 2,000 (508) P 3,940 (700) Cr P S</p>	<p>ø22,0 x 71,0</p>			
<p>ø80,00</p> <p>4 Cyl.Benzin 1116cc 41 Kw (56 Ps) 2 Cyl.Benzin704cc 17/22Kw (24/30 Ps) 170 A.000/A.046 171.A.000 126A2.000 024AA.07A0 138A/B.000 <u>93-96/87-92/83-89</u> Cinquecento 700 ED 126 Bis 700 Regata 60 Uno 55/55S/60</p> 	<p>18-2010090 STD</p>	<p>A = 34,000 B = 60,000</p>	<p>RE22130000 -STD RE22130040 -0.40 RE22130060 -0.60 RE22130080 -0.80 RE22130100 -1.00</p> <p>1,500 (500) CrB Fe S 2,000 (508) P 3,940 (700) Cr P S</p>	<p>ø20,0 x 54,0</p>			



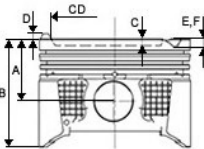



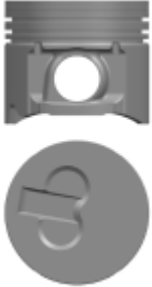
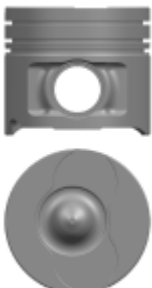

							
Motor /Engine	Ref. No. Kit 1	Ölçüler /Dimensions	Segman /Rings	Pim	Gömlek /Liner	Kit 2	Info
<p>ø80,50</p> <p>4.Cyl. Benzin 1372 cc 45 Kw (60 Ps) M202 PA 13.0 M605PB.13.J014 160A1.000 <u>1990-1994</u></p> <p><i>Tipo 1.4 Uno 70 Uno S Uno SX Tipo 1.4 ie Tempra</i></p> 	<p>18-2010800 STD 18-2010802 0.40 18-2010804 0.60</p>	<p>A = 33,300 B = 63,500 C = 2,800 D = 71,000 F = -3,050</p>	<p>RE22150000 -STD RE22150040 -0.40 RE22150060 -0.60</p> <p>1,500 (500) Cr B S IF 1,750 (508) P 3,000 (700) Cr P S</p>	<p>ø22,0 x 58,2</p>			
<p>ø80,50</p> <p>4 Cyl. Benzin 1372 cm³ 84 100 kW (114 136 hp) 7 8:1 M603 BT 13.0 <u>1990-1993</u></p> <p><i>Uno Turbo Punto GT</i></p>	<p>18-2010820 STD 18-2010822 0.40 18-2010824 0.60</p>	<p>A = 33,300 B = 61,300 C = 2,000 E = -3,500 CD= 70,500</p>	<p>RE22670000 -STD RE22670040 -0.40 RE22670060 -0.60</p> <p>1,500 (500) CrSIF 2,000 (501) Fe 3,000 (700) Cr P S</p>	<p>ø22,0 x 58,0</p>			



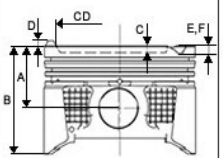





							
Motor /Engine	Ref. No. Kit 1	Ölçüler /Dimensions	Segman /Rings	Pim	Gömlek /Liner	Kit 2	Info
<p>ø80,50</p> <p>4 Cyl. Benzin 1301 cm³ 74 kW (100 hp) 7 7:1 M/603 AT 13/0 <u>1985-1991</u> Uno 1,3 Turbo</p>	<p>18-2010830 STD 18-2010832 0.40 18-2010834 0.60</p>	<p>A = 35,000 B = 63,050 C = 3,250</p>	<p>RE22140000 -STD RE22140040 -0.40 RE22140060 -0.60</p> <p>1,500 (500) Cr S IF 2,000 (508) P 4,000 (604) Cr P</p>	<p>ø22,0 x 58,0</p>			
<p>ø80,50</p> <p>4 Cyl. Benzin 1596 cc 76 Kw (103 Ps) 182/B6/000 <u>1997-2003</u> Brava 1,6 16v Bravo 1,6 16v Doblo 1,6 16v Marea 1,6 16v Palio 1,6 16v Stilo 1,6 16v</p>	<p>18-2010840 STD 18-2010841 0.25 18-2010842 0.40</p>	<p>A = 28,650 B = 50,700 C = 1,200 E = -2,200 F = -2,800</p>	<p>RE22760000 -STD RE22760040 -0.40</p> <p>1,200 (500) NitB S IF 1,200 (508) P 2,000 (700) Nit S</p>	<p>ø21,0 x 56,0</p>			



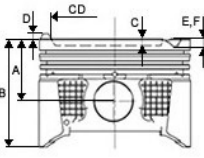





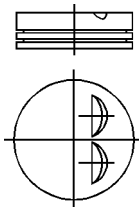

							
Motor /Engine	Ref. No. Kit 1	Ölçüler /Dimensions	Segman /Rings	Pim	Gömlek /Liner	Kit 2	Info
<p>ø80,50</p> <p>4 Cyl. Benzin 1372 cc Şahin S (Oyuklu) 138 <u>1992 -</u> Şahin S 1,4</p>	<p>18-2010930 STD 18-2010932 0.40 18-2010934 0.60 18-2010935 0.65</p>	<p>A = 33,300 B = 63,500 C = 2,900 CD= 71,000</p>	<p>RE22150000 -STD RE22150040 -0.40 RE22150060 -0.60</p> <p>1,500 (500) Cr B S IF 1,750 (508) P 3,000 (700) Cr P S</p>	<p>ø22,0 x 58,2</p>			
<p>ø82,00</p> <p>4 Cyl. Diesel 1910 cm³ 76 kW (104 hp) 18 5:1 M724 BT 19/T M722 BT 24/T <u>1998-2000</u></p> <p>Brava Bravo Doblo Marea</p>	<p>18-2050930 STD 18-2050932 0.40 18-2050934 0.60</p>	<p>A = 47,250 B = 73,250 C = 17,500 CD= 37,500</p> <p>Segman Taşıyıcı (Ring Carrier)</p> <p>Yağ Püskürt. Oyugu (Oil Cut-Out)</p>	<p>RE22700000 -STD RE22700040 -0.40 RE22700060 -0.60</p> <p>3,000 (504) Cr P 2,000 (501) P IFU 3,000 (604) Cr P</p>	<p>ø26,0 x 61,0</p>			



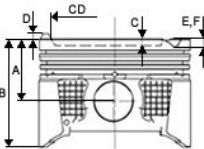



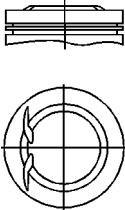

							
Motor /Engine	Ref. No. Kit 1	Ölçüler /Dimensions	Segman /Rings	Pim	Gömlek /Liner	Kit 2	Info
<p>ø82,00</p> <p>4 Cyl. Diesel 1910 cc 63 Ps 22 6:1 223A.6000 <u>2000-....</u> Doblo 1.9 D</p>	<p>18-2050960 STD 18-2050960-20 STD (-0.20 mm) 18-2050962 0.40 18-2050962-20 0.40 (-0.20 mm) 18-2050964 0.60 18-2050964-20 0.60 (-0.20 mm) 18-2050967 0.80 18-2050967-20 0.80 (-0.20 mm) 18-2050968 1.00</p> 	<p>A = 44,500 B = 70,300 C = 1,300</p>	<p>RE22730000 -STD RE22730040 -0.40 RE22730060 -0.60 RE22730080 -0.80 RE22730100 -1.00</p> <p>2,000 (500) Cr P 2,000 (508) P 2,000 (604) Cr P</p>	<p>ø26,0 x 65,0</p>			<p>0,76 0,84 mm conta + 0,045 + 0,125</p> <p>0,86 0,94 mm conta + 0,126 + 0,225</p> <p>0,96 1,04 mm conta + 0,226 + 0,305</p>
<p>ø82,00</p> <p>4 Cyl. Diesel 1910 cc 77 Kw (103 Ps) Z19DT 182B.9000 <u>2001-....</u> Doblo 1.9 JTD</p>	<p>18-3051940 STD 18-3051942 0.40 18-3051947 0.80</p> 	<p>A = 46,500 B = 72,500 C = 17,450 E = -0,650 CD= 37,550</p> <p>Segman Taşıyıcı (Ring Carrier)</p> <p>Burc (Bushing)</p>	<p>RE22730000 -STD RE22730040 -0.40 RE22730060 -0.60 RE22730080 -0.80 RE22730100 -1.00</p> <p>2,000 (500) Cr P 2,000 (508) P 2,000 (604) Cr P</p>	<p>ø26,0 x 61,0</p>			<p>0,77 0,87mm conta +0,014 +0,104</p> <p>0,87 0,97mm conta +0,105 +0,205</p> <p>0,97 1,07mm conta +0,236 +0,294</p>



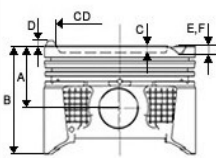
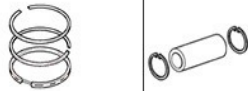



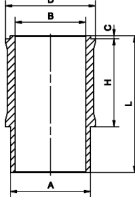

Motor /Engine	Ref. No. Kit 1	Ölçüler /Dimensions	Segman /Rings	Pim	Gömlek /Liner	Kit 2	Info
							
ø82,00 4 Cyl. Diesel 1900 cc 110 Kw 1/9 JTD Euro 4 16 V 2000 -.... Astra Zafira Vectra&Signum Signum Vectra Zafira Doblo 1.9 JTD Bravo 1.9 JTD Stilo 1.9 JTD	18-3083440 STD 18-3083442 0.40	A = 46,500 B = 72,500 C = 15,400 E = -1,070 F = -1,020 CD= 41,500 Segman Taşıyıcı (Ring Carrier) Yag Galerisi (Oil Gallery)	RE22730000 -STD RE22730040 -0.40 RE22730060 -0.60 RE22730080 -0.80 RE22730100 -1.00 2,000 (500) Cr P 2,000 (508) P 2,000 (604) Cr P	ø30,0 x 67,0			
ø82,60 4 Benzin, 1698 cc 40/42/44 48/52/59/62kW 57/58/60/65 70/80/82 ps 138C.000 146 B2.000 149/176 B3/B4.000 149/280 A1/B1.000 160 A7.000 M705BA.190 149 B5.046 831D/D1.000 1984 Tempra 1.7D Marengo/Talento/1.9D Uno/Tipo/Bravo/Bravo Prisma D/Delta 1.9D Ducato 10-14 1.9D-Turbo Strada/Duna/Siena 1.7D Punto/Palio Mondo 1.7D Uno 1.7D/60 1.7D Ritmo/Regata 1.7D 60 1.7D/65-80 1.9D	18-2050940 STD 18-2050942 0.40 18-2050944 0.60	A = 42,600 B = 84,400 D = 2,400	RE22170000 -STD RE22170040 -0.40 RE22170060 -0.60 RE22170080 -0.80 2,500 (504) Cr 2,000 (508) P 4,000 (604) Cr P	ø25,0 x 69,5			



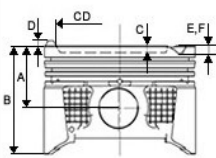





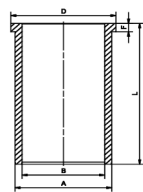

							
Motor /Engine	Ref. No. Kit 1	Ölçüler /Dimensions	Segman /Rings	Pim	Gömlek /Liner	Kit 2	Info
<p>ø84,00</p> <p>4 Cyl. Benzin 1585 cm³ 55 kW (75 hp) 9 2:1 131AB.IA.0 <u>1974-1981</u> 131</p>	<p>18-2010600 STD 18-2010602 0.40 18-2010604 0.60 18-2010607 0.80</p>	<p>A = 38,450 B = 77,950</p>	<p>RE22230000 -STD RE22230040 -0.40 RE22230060 -0.60 RE22230080 -0.80</p> <p>1,500 (500) CrB Fe S IF 2,000 (508) P 3,947 (605) P</p>	<p>ø22,0 x 69,1</p>			
<p>ø84,00</p> <p>4 Cyl. Benzin 1756 cm³ 101 kW (138 hp) 9 9:1 4 VALVES M607 AA/18/0 <u>1974-1982</u> Tipo</p>	<p>18-2010610 STD 18-2010612 0.40</p>	<p>A = 38,800 B = 67,400 D = 0,600 E = -1,000 F = -2,200</p> <p>Yag Püskürt. Oyugu (Oil Cut-Out)</p>	<p>RE22230000 -STD RE22230040 -0.40 RE22230060 -0.60 RE22230080 -0.80</p> <p>1,500 (500) CrB Fe S IF 2,000 (508) P 3,947 (605) P</p>	<p>ø22,0 x 63,0</p>			

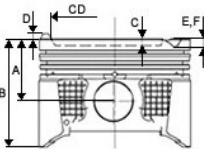





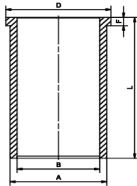

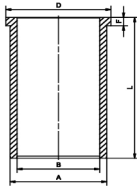



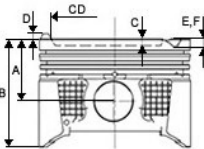





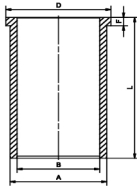

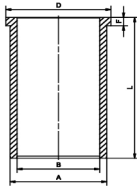
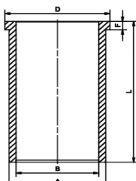
							
Motor /Engine	Ref. No. Kit 1	Ölçüler /Dimensions	Segman /Rings	Pim	Gömlek /Liner	Kit 2	Info
<p>ø84,00</p> <p>4 Cyl. Benzin 1995 cm³ 151 kW (205 hp) 8:1 M615 HA.20.0</p> <p><u>1994</u></p> <p>Tempra 2,0 16v Tipo 2,0 16v</p>	<p>18-2010680 STD 18-2010682 0.40</p>	<p>A = 39,800 B = 67,800 C = 2,050 E = -2,800 CD= 59,000</p> <p>Sac Plaka (Steel Support)</p> <p>Yag Püskürt. Oyugu (Oil Cut-Out)</p> 	<p>RE22220000 -STD RE22220040 -0.40 RE22220060 -0.60</p> <p>1,500 (500) CrB Fe S 1,500 (508) P 3,000 (700) NiT S</p>	<p>ø22,0 x 63,0</p>			
<p>ø84,00</p> <p>4 Cyl. Benzin 1995 cm³ 151 kW (205 hp) 8:1 M611 LA 20.C025 M601 SA 20.A</p> <p><u>1990</u></p> <p>Tempra 2,0 8v Tipo 2,0 8v</p>	<p>18-2010690 STD 18-2010692 0.40</p>	<p>A = 39,800 B = 67,800 C = 1,600 E = -4,600 F = -5,600 CD= 50,800</p> <p>Sac Plaka (Steel Support)</p> <p>Yag Püskürt. Oyugu (Oil Cut-Out)</p>	<p>RE22220000 -STD RE22220040 -0.40 RE22220060 -0.60</p> <p>1,500 (500) CrB Fe S 1,500 (508) P 3,000 (700) NiT S</p>	<p>ø22,0 x 63,0</p>			



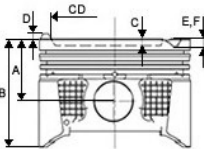



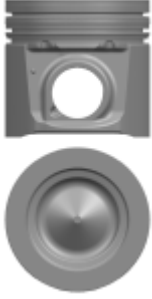
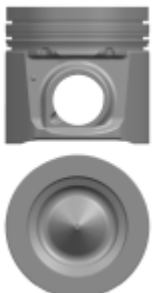

							
Motor /Engine	Ref. No. Kit 1	Ölçüler /Dimensions	Segman /Rings	Pim	Gömlek /Liner	Kit 2	Info
<p>ø84,00</p> <p>4 Cyl. Benzin 1796cc 49 51kW(69 PS) 7,5:1,8 Ventile C25 1.8 169 (XM7T) <u>07/87-02/94</u></p> <p>C25 1.8 E C25 1.8 E7/87-2/94 DUCATO 1.8 1/82-10/88 504 1.8 1/71-12/89 505 1.8 6/81-10/85 15 1.8 1/83-11/88 7/70-3/80</p>	<p>18-7510020 STD Gömleklili Kodu 19-7510020 STD</p>	<p>A = 37,800 B = 70,250</p>	<p>RE22280000 -STD</p> <p>1,500 (500) Cr S IF 2,000 (508) P 4,000 (700) Cr P S</p>	<p>ø23,0 x 70,0</p>	<p>G93001362S_1</p> <p>A= 93,000 B= 84,000 D= 99,200 F= 0,000 H= 90,000 L= 136,200</p> 		
<p>ø85,00</p> <p>4/6 Cyl. Diesel 2179 cc 110 KW 211 PS DW12BTED4 <u>2011 - 2013</u> FREELANDER 2 2.2 TD4</p>	<p>17-6592300 STD 17-6592303 0.50</p>	<p>A = 48,705 B = 74,705 C = 13,475 E = -0,385 CD= 52,400</p> <p>Segman Taşıyıcı (Ring Carrier)</p> <p>Yag Galerisi (Oil Gallery)</p> <p>Yag Püskürt. Oyugu (Oil Cut-Out)</p> 	<p>RE35000000 -STD RE35000050 -0.50</p> <p>2,500 (505) Cr P 2,000 (501) P IFU 2,000 (604) Nit S</p>	<p>ø30,0 x 68,0</p>			



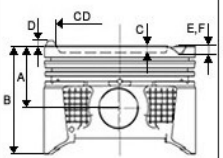





Motor /Engine	Ref. No. Kit 1	Ölçüler /Dimensions	Segman /Rings	Pim	Gömlek /Liner	Kit 2	Info
       							
ø85,00 4 Cyl. Diesel 1997/1998 cc 79/80/81/100Kw 90/107/109Ps 110/136 Ps DW10ATED TD10ATED DW10TD Euro 3 G6DB RHS RHW RHX RHY RHZ D420 4T <u>1998 -</u> 2.0 HDI 206/306/307/406 Boxer Partner Expet C5 Jumpy Xsara Scudo 2.0JTD Cmax Focus II Grand Vitara C30 C70 S40/80 II V50 V70 III TDI	18-7550900 STD 18-7550900-20 STD (-0.20 mm) 18-7550900-40 STD (-0.40 mm) 18-7550903 0.50 18-7550904 0.60	A = 46,750 B = 80,750 C = 18,300 E = -1,000 CD= 38,000 Segman Taşıyıcı (Ring Carrier) Yag Püskürt. Oyugu (Oil Cut-Out)	RE47440000 -STD RE47440060 -0.60 3,500 (505) Cr P 2,000 (501) P IFU 3,000 (604) Cr P	ø28,0 x 70,0			1,25 mm conta +0,55 + 0,60 1,30 mm conta +0,61 +0,65 1,35 mm conta +0,66 +0,70 1,40 mm conta +0,71 +0,75
ø86,01 4 Cyl. Diesel 2198/2200 cc 100/120/130/150 Ps 17,5:1 QWFB/V347 Duratorq Euro 4 Duratorq/V347 D CD132 Duratorq TDCI <u>2003/2008..</u> Common Rail Transit 2.2 TDCI Yeni Jumper 2.2 HDI Ducato 100 Multijet Yeni Boxer HDI Mondeo 2.2 TDCI Transit 2.2 TDCI	18-2582350 STD 18-2582350-20 STD (-0.20 mm) 18-2582351 0.25 18-2582353 0.50 18-2582353-20 0.50 (-0.20 mm)	A = 43,420 B = 69,820 C = 15,850 CD= 46,900 Segman Taşıyıcı (Ring Carrier) Yag Galerisi (Oil Gallery)	RE23350000 -STD RE23350025 -0.25 RE23350050 -0.50 2,000 (500) Cr P IF 2,000 (508) P 2,000 (604) Nit S	ø30,0 x 66,9	G86011560K_1 A= 89,000 B= 85,310 D= 90,500 F= 5,000 H= 0,000 L= 156,000		1,10 mm conta +0,38 +0,47 1,20 mm conta +0,48 +0,58 1,30 mm conta + 0,59 +0,68



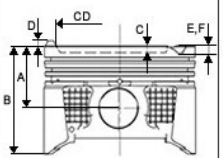



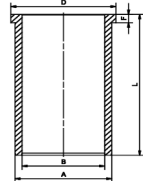

							
Motor /Engine	Ref. No. Kit 1	Ölçüler /Dimensions	Segman /Rings	Pim	Gömlek /Liner	Kit 2	Info
<p>ø86,40</p> <p>4 Cyl. Benzin 1581 cc M202PA.15/A <u>1990-1993</u> Şahin S</p>	<p>18-2010850 STD 18-2010852 0.40 18-2010854 0.60</p> 	<p>A = 33,300 B = 65,300 C = 2,800 CD= 71,000</p>	<p>RE22300000 -STD RE22300040 -0.40 RE22300060 -0.60</p> <p>1,500 (500) CrB Fe S 1,750 (508) P 3,000 (700) Cr P S</p>	<p>ø22,0 x 63,2</p>	<p>G90001270K_1</p> <p>A= 90,000 B= 86,400 D= 91,000 F= 5,000 H= 0,000 L= 127,000</p> 		
<p>ø86,40</p> <p>4 Cyl. Benzin 1581 cc 72 Kw (96 Ps) M202PB.15.A <u>1990-....</u> Tempra 1.6 SX Tipo 1.6 Punto 1.6 Scudo 1.6</p>	<p>18-2010860 STD 18-2010862 0.40 18-2010864 0.60</p> 	<p>A = 33,300 B = 65,300 C = 2,300 E = -3,200 CD= 71,000</p>	<p>RE22300000 -STD RE22300040 -0.40 RE22300060 -0.60</p> <p>1,500 (500) CrB Fe S 1,750 (508) P 3,000 (700) Cr P S</p>	<p>ø22,0 x 63,2</p>	<p>G90001270K_1</p> <p>A= 90,000 B= 86,400 D= 91,000 F= 5,000 H= 0,000 L= 127,000</p> 		



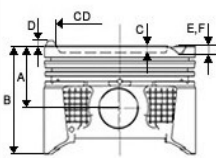



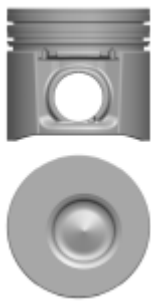

							
Motor /Engine	Ref. No. Kit 1	Ölçüler /Dimensions	Segman /Rings	Pim	Gömlek /Liner	Kit 2	Info
<p>ø86,40</p> <p>4 Cyl. Benzin 1581 cc 103 Ps 182B6000 <u>1998-...</u> <i>Brava 1,6 16v</i> <i>Marea 1,6 16v</i> <i>Albea 1,6 16v</i></p>	<p>18-2010870 STD 18-2010872 0.40 18-2010874 0.60</p>	<p>A = 34,170 B = 59,430 E = -2,200 F = -2,800</p>	<p>RE22590000 -STD RE22590040 -0.40 RE22590060 -0.60</p> <p>1,500 (500) Cr P IW 1,500 (501) P IWU 3,000 (700) Cr P S</p>	<p>ø22,0 x 56,0</p>	<p>G90001270K_1</p> <p>A= 90,000 B= 86,400 D= 91,000 F= 5,000 H= 0,000 L= 127,000</p> 		
<p>ø86,40</p> <p>4 Cyl. Benzin 1581 cm³ 76 kW (103 hp) 10 5:1 4 Valves 182 A.4 000 Euro 2 <u>... 02/1999</u> <i>Brava 1,6 16v</i> <i>Marea 1,6 16v</i> <i>Bravo 1,6 16v</i></p>	<p>18-2010880 STD 18-2010882 0.40</p>	<p>A = 34,170 B = 56,170 C = 0,530 E = -2,000 CD= 65,000</p>	<p>RE22590000 -STD RE22590040 -0.40 RE22590060 -0.60</p> <p>1,500 (500) Cr P IW 1,500 (501) P IWU 3,000 (700) Cr P S</p>	<p>ø22,0 x 56,0</p>	<p>G90001270K_1</p> <p>A= 90,000 B= 86,400 D= 91,000 F= 5,000 H= 0,000 L= 127,000</p> 		



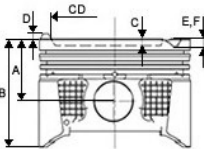





							
Motor /Engine	Ref. No. Kit 1	Ölçüler /Dimensions	Segman /Rings	Pim	Gömlek /Liner	Kit 2	Info
<p>ø88,00</p> <p>4 Cyl. Diesel 2286 cc 81 KW (120 PS) F1AE0481D EURO 4 <u>2002-....</u></p> <p><i>Ducato Multijet (Box 120 2,3 D Bus 120 2,3 D Platform/Chassis 120M)</i></p>	<p>18-2051330 STD</p> <p><i>18-2051330-20 STD (-0.20 mm)</i></p> <p>18-2051334 0.60</p> <p><i>18-2051334-20 0.60 (-0.20 mm)</i></p> 	<p>A = 57,000 B = 84,000 C = 13,750 CD= 50,100</p> <p>Segman Taşıyıcı (Ring Carrier)</p> <p>Yag Galerisi (Oil Gallery)</p> <p>Yag Püskürt. Oyugu (Oil Cut-Out)</p>	<p>RE22910000 -STD RE22910040 -0.40 RE22910060 -0.60</p> <p>2,500 (504) Cr 2,000 (501) P IF 2,500 (604) Cr P</p>	<p>ø31,0 x 67,0</p>			
<p>ø88,00</p> <p>4 Cyl. Diesel 2287 cc 96 kW 131 HP F1AE3481D <u>....-....</u></p> <p><i>VANS DUCATO 2.3D 250</i></p>	<p>18-2092900 STD</p> <p>18-2092902 0.40</p> <p>18-2092904 0.60</p> 	<p>A = 57,000 B = 84,000 C = 14,300 CD= 61,600</p> <p>Segman Taşıyıcı (Ring Carrier)</p> <p>Yag Galerisi (Oil Gallery)</p> <p>Yag Püskürt. Oyugu (Oil Cut-Out)</p>	<p>RE22950000 -STD RE22950040 -0.40 RE22950060 -0.60</p> <p>1,750 () 1,500 () P 2,000 ()</p>	<p>ø31,0 x 67,0</p>			



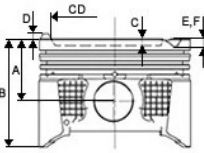





Motor /Engine	Ref. No. Kit 1	Ölçüler /Dimensions	Segman /Rings	Pim	Gömlek /Liner	Kit 2	Info
							
ø88,00 4 Cyl. Diesel 2287 cc 96 kW 131 HP F1AE3481D - TRANSPORTER DUCATO 2.3 D 250/290 4X4 MULTIJET	18-2092910 STD 18-2092912 0.40 18-2092914 0.60	A = 57,000 B = 84,000 C = 14,300 CD= 61,600 Segman Taşıyıcı (Ring Carrier) Yag Galerisi (Oil Gallery) Yag Püskürt. Oyugu (Oil Cut-Out)	RE22910000 -STD RE22910040 -0.40 RE22910060 -0.60 2,500 (504) Cr 2,000 (501) P IF 2,500 (604) Cr P	ø31,0 x 67,0			
ø93,00 4 Cyl. Diesel 2499 cc 63 Kw (83 Ps) 8140.67 1994-..... Sofim Doğal Emişli Ducato 2.5 D	18-2051350 STD 18-2051352 0.40	A = 54,000 B = 89,000 C = 2,200 Segman Taşıyıcı (Ring Carrier) Sert Anotlama (Hard Anodising) Yag Püskürt. Oyugu (Oil Cut-Out)	RE22340000 -STD RE22340040 -0.40 RE22340060 -0.60 3,000 (504) Cr P 2,000 (501) P 3,000 (604) Cr P	ø32,0 x 75,2			1,60 mm conta + 0,75 + 0,81 1,80 mm conta + 0,82 + 1,14

Motor /Engine	Ref. No. Kit 1	Ölçüler /Dimensions	Segman /Rings	Pim	Gömlek /Liner	Kit 2	Info
       							
ø93,00 4 Cyl. Diesel 2499 cc 62 Kw (85 Ps) Atmospheric Göz Arası Konik SOFIM 2/5 Düz 2001 -.... Ducato 2.5 D Movano 2.5 D Master 2.5 D	18-3051880 STD 18-3051880-20 STD (-0.20 mm) 18-3051882 0.40 18-3051882-20 0.40 (-0.20 mm)	A = 54,000 B = 89,000 C = 2,200 Segman Taşıyıcı (Ring Carrier) Sert Anotlama (Hard Anodising) Yag Püskürt. Oyugu (Oil Cut-Out)	RE22340000 -STD RE22340040 -0.40 RE22340060 -0.60 3,000 (504) Cr P 2,000 (501) P 3,000 (604) Cr P	ø32,0 x 68,0	G96001670K_1 A= 96,000 B= 93,000 D= 98,900 F= 5,000 H= 0,000 L= 167,300		+0,40 +0,50 1.20 mm Conta +0,51 +0,60 1.30 mm Conta +0,61 +0,70 1.40 mm Conta
ø94,40 4 Cyl. Diesel 2798 cc 64 Kw (87 Ps) Sofim Motor 8140.63.3700 1998 - 1999 Ducato 14 2.8 D Ducato Maxi 2.8D	18-2051130 STD 18-2051132 0.40 18-2051134 0.60	A = 55,000 B = 90,000 C = 1,700 Segman Taşıyıcı (Ring Carrier) Sert Anotlama (Hard Anodising) Yag Püskürt. Oyugu (Oil Cut-Out)	RE22790000 -STD RE22790040 -0.40 RE22790060 -0.60 3,000 (504) Cr P 2,000 (501) P IWU 2,500 (604) Cr P	ø32,0 x 68,0			+ 0,40 + 0,50 (1.20 mm Conta) + 0,51 + 0,60 (1.30 mm Conta) + 0,61 + 0,70 (1.40 mm Conta)

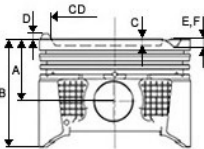





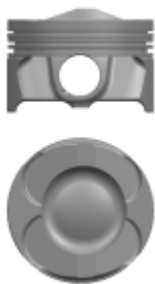

Motor /Engine	Ref. No. Kit 1	Ölçüler /Dimensions	Segman /Rings	Pim	Gömlek /Liner	Kit 2	Info
							
ø94,40 4 Cyl. Diesel 2798 cc 107 Kw (146 Ps) 18 5:1 SOFIM 8140.43S.4000 Euro 3 8140.23.2585/3700 Euro 3 8140.63.3700 8140.43M. 4300/4320/4330 Euro 3 <u>2000-....</u> Ducato 2.8 JTD (35C.15/35S.15/50C.15 60C.15 TD/65C.15 65C.13 Daily Unijet) Boxer 2.8 HDI	18-2081440 STD 18-2081440-20 STD (-0.20 mm) 18-2081442 0.40 18-2081442-20 0.40 (-0.20 mm) 18-2081444 0.60 18-2081444-20 0.60 (-0.20 mm)	A = 58,700 B = 87,600 C = 21,300 CD= 39,500 Segman Taşıyıcı (Ring Carrier) Yag Galerisi (Oil Gallery) Yag Püskürt. Oyugu (Oil Cut-Out)	RE22780000 -STD RE22780040 -0.40 RE22780060 -0.60 2,500 (504) Cr P 2,000 (501) P 2,500 (604) Cr P	ø32,0 x 72,0			1,20 mm conta + 0,40 + 0,50 1,30 mm conta + 0,51 + 0,60 1,40 mm conta + 0,61 + 0,70 1,50 mm conta + 0,71 + 0,80
ø94,40 4 Cyl. Diesel 2800 cc 76 Kw (103 Ps) 18 5:1 8140.23.2585 8140.43.2585 Motor No: > 2572279 <u>1996 - 1999</u> 35.10, 49.10 M14 Minibüs Turbo Daily	18-2081550 STD 18-2081552 0.40 18-2081554 0.60	A = 58,750 B = 96,750 C = 19,400 CD= 39,400 Segman Taşıyıcı (Ring Carrier) Yag Galerisi (Oil Gallery) Yag Püskürt. Oyugu (Oil Cut-Out)	RE22560000 -STD RE22560040 -0.40 RE22560060 -0.60 3,000 (504) Cr P 2,000 (501) P IWU 3,000 (604) Cr P	ø32,0 x 78,1			1,20 mm conta + 0,40 + 0,50 1,30 mm conta + 0,51 + 0,60 1,40 mm conta + 0,61 + 0,70 1,50 mm conta + 0,71 + 0,80



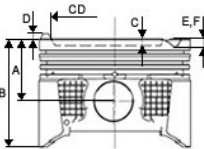





							
Motor /Engine	Ref. No. Kit 1	Ölçüler /Dimensions	Segman /Rings	Pim	Gömlek /Liner	Kit 2	Info
<p>ø95,80</p> <p>4 Cyl. Diesel 2998 cc 156 PS18:01 T3.0 F1C/HDI EURO 5</p> <p>.... -</p> <p>JUMPER</p>	<p>18-2092980 STD 18-2092982 0.40</p>	<p>A = 63,000 B = 93,400 C = 16,000 CD= 53,200</p> <p>Segman Taşıyıcı (Ring Carrier)</p> <p>Yag Galerisi (Oil Gallery)</p> <p>Yag Püskürt. Oyugu (Oil Cut-Out)</p>	<p>RE22870000 -STD RE22870040 -0.40</p> <p>2,500 (504) Cr P 2,000 (501) P 2,500 (604) P</p>	<p>ø36,0 x 80,8</p>			



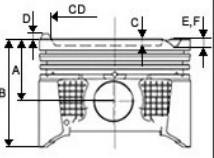



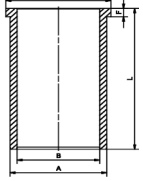
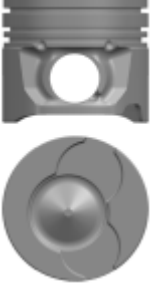
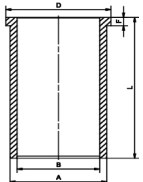
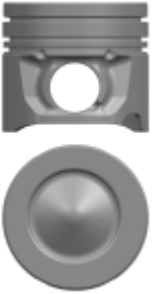

							
Motor /Engine	Ref. No. Kit 1	Ölçüler /Dimensions	Segman /Rings	Pim	Gömlek /Liner	Kit 2	Info
<p>ø68,70</p> <p>4 Cyl. Benzin, 1119 cm³ 40 kW (55 hp) GUD GUE</p> <p><u>1989-1992</u></p> <p>Fiesta Escort</p>	<p>18-2510750 STD 18-2510753 0.50 18-2510758 1.00</p>	<p>A = 29,400 B = 53,900</p>	<p>RE23000000 -STD RE23000050 -0.50 RE23000100 -1.00</p> <p>1,500 (500) Cr S 1,750 (508) P 3,000 (700) Cr P S</p>	<p>ø18,0 x 59,0</p>			
<p>ø68,70</p> <p>4 Cyl. Benzin, 1119 cm³ 37 kW (50 hp) GUF G 6 A</p> <p><u>1989-1996</u></p> <p>Fiesta III 1.1</p>	<p>18-2510760 STD 18-2510763 0.50 18-2510768 1.00</p>	<p>A = 29,400 B = 53,900 C = 3,500 CD= 36,000</p>	<p>RE23000000 -STD RE23000050 -0.50 RE23000100 -1.00</p> <p>1,500 (500) Cr S 1,750 (508) P 3,000 (700) Cr P S</p>	<p>ø18,0 x 59,0</p>			



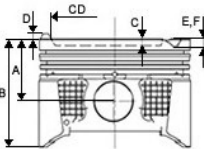





							
Motor /Engine	Ref. No. Kit 1	Ölçüler /Dimensions	Segman /Rings	Pim	Gömlek /Liner	Kit 2	Info
<p>ø70,80</p> <p>4 Benzin, 1242 cc 48kW 65 ps 169A4 199 A4.000</p> <p><u>2005</u></p> <p>Punto EVO 1.2 Grande Punto 1.2i</p>	<p>18-2010200 STD 18-2010202 0.40 18-2010204 0.60</p>	<p>A = 28,600 B = 48,000 C = 3,900</p>	<p>RE22650000 -STD RE22650040 -0.40 RE22650060 -0.60</p> <p>1,200 (500) CrB P S IF 1,200 (501) P 2,500 (700) Cr P S</p>	<p>ø18,0 x 49,0</p>			
<p>ø71,90</p> <p>3 Cyl. Benzin 998 cc 59/74/92 KW 80/100/101/125 PS SFJA/B/C/D SFGA/B/C/D M2GA/DA M1DA/JC/JE/JH/JJ M1JL/JM/JP/JU PAJA/JB/JC/JD</p> <p><u>02/12 -</u></p> <p>1,0L Ecoboost (Focus III Fiesta VI B-MAX TOURNEO&TRANSIT COURIER GRAND TOURNEO CONNECT TRANSIT CONNECT C-MAXII GRAND C-MAX</p>	<p>17-2510840 STD 17-2510843 0.50</p>	<p>A = 27,400 B = 50,900 C = 8,700 D = 5,500 E = -3,200 F = -2,700 CD= 43,700</p> <p>Sert Anotlama (Hard Anodising)</p>	<p>RE23630000 -STD RE23630050 -0.50</p> <p>1,000 (xxx) 1,200 (xxx) 2,000 (xxx)</p>	<p>ø20,0 x 46,8</p>			



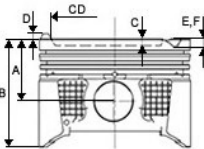









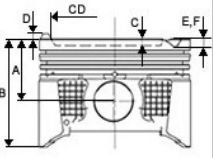



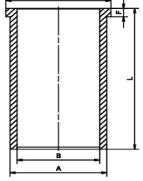
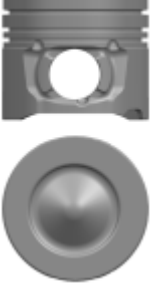
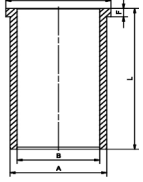
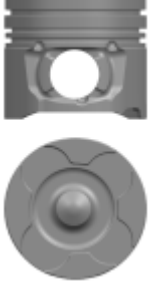

							
Motor /Engine	Ref. No. Kit 1	Ölçüler /Dimensions	Segman /Rings	Pim	Gömlek /Liner	Kit 2	Info
<p>ø71,91</p> <p>4 Cyl. Benzin, 1242 cm³ 55 kW (75 hp) ZtecS DHA DHB DHC DHD DHE DHF DHG ZH12</p> <p><u>1995-2013</u></p> <p><i>Fiesta 1.2 16v Focus 1.2 16v Mazda 121</i></p>	<p>18-2510860 STD 18-2510863 0.50</p>	<p>A = 28,250 B = 53,250 C = 0,930 CD= 52,000</p>	<p>RE23480000 -STD RE23480050 -0.50</p> <p>1,200 (500) CrB P S IF 1,500 (508) P 2,500 (700) Cr P S</p>	<p>ø19,0 x 50,0</p>			
<p>ø73,50</p> <p>4 Cyl. Diesel 1498 cc 55 KW 75 PS 1.5L Duratorq Euro5</p> <p><u>2013 -</u></p> <p><i>B-Max C-Max Fiesta Focus</i></p>	<p>18-2592120 STD 18-2592123 0.50</p>	<p>A = 41,700 B = 65,200 C = 13,400 CD= 45,000</p> <p>Segman Taşıyıcı (Ring Carrier)</p> <p>Yag Galerisi (Oil Gallery)</p> <p>Yag Püskürt. Oyugu (Oil Cut-Out)</p>	<p>RE23660000 -STD RE23660050 -0.50</p> <p>2,000 (xxx) CK 1,950 (xxx) P 2,000 (xxx) CR</p>	<p>ø26,0 x 59,0</p>			



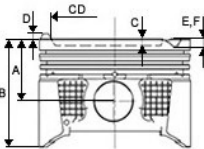



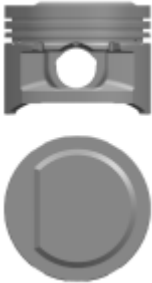
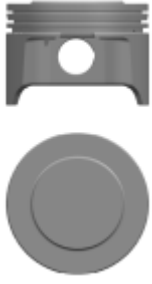

Motor /Engine	Ref. No. Kit 1	Ölçüler /Dimensions	Segman /Rings	Pim	Gömlek /Liner	Kit 2	Info
							
ø73,70 4 Cyl. Diesel 1399 cc 50 Kw (68 Ps) DV4TD DV4 TED DV4C TED F6JA F6JB 8HX 8HR 8HZ 8HS 2002 -.... Fiesta V 1.4 TDCI Fusion 1.4 TDCI Mazda 2 1.4D C2 1.4 HDI C3 I 1.4 HDI XSARA 1.4 HDI NEMO 1.4 HDI 1007 1.4 HDI 107 1.4 HDI 206 1.4 HDI 207 1.4 HDI 307 1.4 HDI BIPPER 1.4 HDI	18-2550150 STD 18-2550150-20 STD (-0.20 mm) 18-2550150-40 STD (-0.40 mm) 18-2550153 0.50 18-2550153-20 0.50 (-0.20 mm) 18-2550153-40 0.50 (-0.40 mm)	A = 42,940 B = 65,440 C = 14,700 E = -1,550 CD= 37,600 Segman Taşıyıcı (Ring Carrier) Yag Püskürt. Oyugu (Oil Cut-Out)	RK25273700010 -STD RK25273700013 -0.50 2,500 (505) CrB P 1,950 (508) P IFU 2,500 (604) Cr P	ø25,0 x 60,0	G76701360K_1 A= 76,700 B= 73,000 D= 78,200 F= 5,000 H= 0,000 L= 136,000 		1 çentik 1,351mm conta +0,776 +0,825 2 çentik 1,252mm conta +0,618 +0,725 3 çentik 1,303mm conta +0,726 +0,775 4 çentik 1,400mm conta +0,83 +0,88 5 çentik 1,450mm conta +0,88 0,98
ø73,70 4 Cyl. Diesel 1398cc 68 HP 50 KW DV4C Euro 5 2010 -.... Fiesta V 1.4 TDCI	18-2550160 STD 18-2550163 0.50	A = 42,900 B = 65,400 C = 12,500 CD= 45,100 Segman Taşıyıcı (Ring Carrier) Yag Püskürt. Oyugu (Oil Cut-Out)	RE23580000 -STD RE23580050 -0.50 2,500 (514) Cr P 1,950 (508) P IFU 2,000 (604) Nit S	ø25,0 x 60,0	G73701360K_1 A= 76,700 B= 68,900 D= 78,200 F= 5,000 H= 0,000 L= 142,000 		

							
Motor /Engine	Ref. No. Kit 1	Ölçüler /Dimensions	Segman /Rings	Pim	Gömlek /Liner	Kit 2	Info
<p>ø73,94</p> <p>4 Cyl. Benzin, 935 cm³ 29 kW (40 hp), 8,3:1 1000TK B LC CR <u>1976-1983</u></p> <p>Fiesta L GL Popular</p>	<p>18-2510120 STD</p>	<p>A = 38,400 B = 64,400</p>	<p>RE23020000 -STD RE23020050 -0.50 RE23020100 -1.00</p> <p>1,600 (500) Cr 2,000 (508) P 4,000 (700) Cr Cr P S</p>	<p>ø20,6 x 63,5</p>			
<p>ø73,94</p> <p>4 Cyl. Benzin, 1297 cm³ 44 kW (60 hp), 9,3:1 JLA (BL13H) <u>1985-1988</u></p> <p>Escort 1300 Combi Van Orion 1300 L</p>	<p>18-2510700 STD</p>	<p>A = 39,130 B = 65,130 C = 3,270 CD= 41,500</p>	<p>RE23020000 -STD RE23020050 -0.50 RE23020100 -1.00</p> <p>1,600 (500) Cr 2,000 (508) P 4,000 (700) Cr Cr P S</p>	<p>ø20,6 x 63,5</p>			

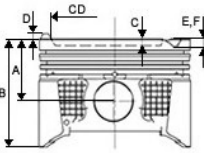





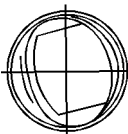

							
Motor /Engine	Ref. No. Kit 1	Ölçüler /Dimensions	Segman /Rings	Pim	Gömlek /Liner	Kit 2	Info
<p>ø73,94</p> <p>4 Cyl. Benzin, 1297 cm³ 44 kW (60 hp)</p> <p>J4C J4D J4J J4K J4L J4M J4N J4P J4Q J4R J4S J4T JB</p> <p><u>1988-1992</u></p> <p><i>Escort IV 1.3</i> <i>Fiesta IV 1.3</i></p> 	<p>18-2510770 STD 18-2510773 0.50 18-2510778 1.00</p>	<p>A = 29,400 B = 53,900</p>	<p>RE23010000 -STD RE23010050 -0.50 RE23010100 -1.00</p> <p>1,500 (500) Cr S IF 1,750 (508) P 3,000 (700) Cr P S</p>	<p>ø18,0 x 64,0</p>			
<p>ø73,94</p> <p>4 Cyl. Benzin, 1297 cm³ 44 kW (60 hp)</p> <p>J4B J6A J6B JBC JBE</p> <p><u>1992 -....</u></p> <p><i>Fiesta III 1.3</i> <i>Escort V 1.3</i> <i>Orion III 1.3 I</i></p>	<p>18-2510850 STD 18-2510853 0.50 18-2510858 1.00</p>	<p>A = 29,400 B = 53,900 C = 3,500 CD= 38,000</p>	<p>RE23010000 -STD RE23010050 -0.50 RE23010100 -1.00</p> <p>1,500 (500) Cr S IF 1,750 (508) P 3,000 (700) Cr P S</p>	<p>ø18,0 x 64,0</p>			



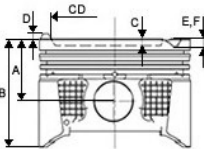



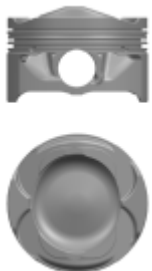

Motor /Engine	Ref. No. Kit 1	Ölçüler /Dimensions	Segman /Rings	Pim	Gömlek /Liner	Kit 2	Info
							
ø75,00 4 Cyl. Diesel 1560cc 70 Kw (95 Ps) 1.6 HDİ (DV6C) EUR5 1.6 HDİ (DV6D) Euro 4 2011 - FOCUS BERLINGO 1.6 8V C4 (B7) DS4 (9HR-9HL) DS5 Grand Picasso II C4 DS4 DS3 C3 C3 II 3008 308 5008 508 Partner Tepee 2008 308 SW 207 SW 208 207	18-2581660 STD 18-2581660-20 STD (-0.20 mm) 18-2581660-40 STD (-0.40 mm) 18-2581663 0.50 18-2581663-20 0.50 (-0.20 mm) 18-2581663-40 0.50 (-0.40 mm)	A = 41,750 B = 65,200 C = 13,850 CD= 45,000 Segman Taşıyıcı (Ring Carrier) Yag Galerisi (Oil Gallery) Yag Püskürt. Oyugu (Oil Cut-Out)	RE23550000 -STD RE23550050 -0.50 2,500 (514) Cr P 1,950 (508) P 2,000 (604) Nit S	ø26,0 x 61,0	G78001420K_1 A= 78,000 B= 74,300 D= 79,500 F= 5,000 H= 0,000 L= 142,000 		1 Kertik 0,5 mm 0,63 mm 2 Kertik 0,63 mm 0,68 mm 3 Kertik 0,68 mm 0,73 mm 4 Kertik 0,73 mm 0,78 mm 5 Kertik 0,78 mm 0,88 mm
ø75,00 4 Cyl. Diesel 1560 cc 80 Kw (109 Ps) DV6TD/TED 2004 - Expert 1,6 HDI 307 1,6 HDI 206 1,6 HDI C4 1,6 HDI Jumpy 1,6 HDI C-Max 1,6 HDI Focus 1,6 HDI	18-2591770 STD 18-2591770-20 STD (-0.20 mm) 18-2591770-40 STD (-0.40 mm) 18-2591773 0.50 18-2591773-20 0.50 (-0.20 mm) 18-2591773-40 0.50 (-0.40 mm) 18-2591774 0.60 18-2591774-20 0.60 (-0.20 mm) 18-2591774-40 0.60 (-0.40 mm)	A = 41,700 B = 65,300 C = 13,250 E = -1,200 CD= 41,800 Segman Taşıyıcı (Ring Carrier) Yag Galerisi (Oil Gallery) Yag Püskürt. Oyugu (Oil Cut-Out)	RE47460000 -STD RE47460040 -0.40 RE47460050 -0.50 RE47460060 -0.60 3,000 (505) CKP 1,950 (508) P 2,500 (604) CrP	ø26,0 x 61,0	G78001420K_1 A= 78,000 B= 74,300 D= 79,500 F= 5,000 H= 0,000 L= 142,000 		1.35 mm conta +0,68 +0,73 1.25 mm conta +0,53 +0,63 1.30 mm conta +0,63 +0,68 1.40 mm conta +0,73 +0,78 1.45 mm conta +0,78 +0,88

							
Motor /Engine	Ref. No. Kit 1	Ölçüler /Dimensions	Segman /Rings	Pim	Gömlek /Liner	Kit 2	Info
<p>ø76,00</p> <p>4 Cyl. Benzin 1597 cc 65 Kw (89 P) ZH16 ZETEC E L1E L1F L1G L1H L1J L1K L1L L1N L1Q LUH LUJ</p> <p><u>1992 -....</u></p> <p>Escort Fiesta Mendesö Orion</p> 	<p>18-2510800 STD 18-2510803 0.50 18-2510808 1.00</p>	<p>A = 32,650 B = 58,350 D = 1,700 CD= 61,400</p>	<p>RE23030000 -STD RE23030050 -0.50 RE23030100 -1.00</p> <p>1,500 (500) CrB Fe S 1,600 (508) P 2,500 (700) Cr P S</p>	<p>ø20,6 x 63,5</p>			
<p>ø76,00</p> <p>4 Cyl. Benzin 1400cc 80 Ps FXDA FXDB FXDC FXJA FXJB</p> <p><u>2002 - 2011</u></p> <p>Fiesta 1.4 Puma 1.4 Mazda 2 1,4i 16v Mazda 3 1,4i 16v</p> 	<p>18-2510870 STD 18-2510873 0.50</p>	<p>A = 28,250 B = 55,500 D = 1,250</p>	<p>RE23540000 -STD RE23540050 -0.50</p> <p>1,200 (500) NitB S 1,500 (501) P 2,500 (700) Nit S</p>	<p>ø19,0 x 50,0</p>			

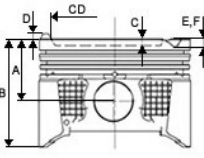





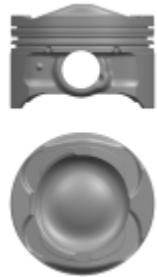
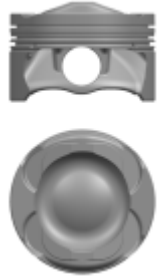

							
Motor /Engine	Ref. No. Kit 1	Ölçüler /Dimensions	Segman /Rings	Pim	Gömlek /Liner	Kit 2	Info
<p>ø76,01</p> <p>4 Cyl. Benzin 1388cc 66 Kw (90 Ps)10.3:1 FHF Zetec SE DOHC 16V EFi ZH14 <u>1997 -2010..</u></p> <p><i>Fiesta 1.4 Puma 1.4 16V</i></p>	<p>18-2510880 STD 18-2510883 0.50</p>	<p>A = 32,650 B = 58,350 D = 1,700 CD= 61,400</p>	<p>RE23030000 -STD RE23030050 -0.50 RE23030100 -1.00</p> <p>1,500 (500) CrB Fe S 1,600 (508) P 2,500 (700) Cr P S</p>	<p>ø20,6 x 63,4</p>			
<p>ø77,25</p> <p>4 Cyl. Benzin, 1396 cm³ 54 55 kW (73 75 hp), 9,5:1 1.4 CVH FUA CR <u>1985-1992</u></p> <p><i>Fiesta Escort Orion</i></p>	<p>18-2510670 STD</p>	<p>A = 39,200 B = 75,000 D = 5,800</p>	<p>RE23020000 -STD RE23020050 -0.50 RE23020100 -1.00</p> <p>1,600 (500) Cr 2,000 (508) P 4,000 (700) Cr Cr P S</p>	<p>ø20,6 x 63,5</p>			



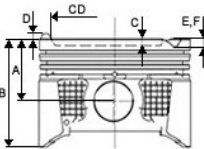









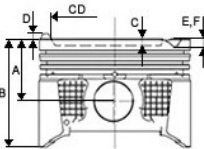







							
Motor /Engine	Ref. No. Kit 1	Ölçüler /Dimensions	Segman /Rings	Pim	Gömlek /Liner	Kit 2	Info
<p>ø77,25</p> <p>4 Cyl. Benzin, 1392 cm³ 44 54,5 kW (60 74 hp) 1. Lit. (CAT) CR</p> <p><u>1984-....</u></p> <p>Escort IV 1.3 Fiesta IV 1.3 Orion</p>	<p>18-2510790 STD</p> 	<p>A = 39,200 B = 71,900 D = 2,700</p>	<p>RE23020000 -STD RE23020050 -0.50 RE23020100 -1.00</p> <p>1,600 (500) Cr 2,000 (508) P 4,000 (700) Cr Cr P S</p>	<p>ø20,6 x 63,5</p>			
<p>ø79,00</p> <p>4 Cyl. Benzin 1496 cc 88/134kW 120/182PS 1.5 Eco Boost DS7G 6105 DS7G 6105 FA M8MA M9MA BNMA UNCAUNCB</p> <p><u>2014 -</u></p> <p>1,5 EcoBoost Focus C-Max Kuga Mondeo</p>	<p>18-2510430 STD 18-2510433 0.50 18-2510438 1.00</p> 	<p>A = 34,850 B = 53,900 C = 9,300 E = -3,530 F = -3,470 CD= 53,500</p> <p>Sert Anotlama (Hard Anodising)</p>	<p>RE43490000 -STD RE43490050 -0.50 RE43490100 -1.00</p> <p>1,200 (500) NitB S 1,200 (501) P 2,000 (700) Cr P S</p>	<p>ø21,0 x 46,0</p>			

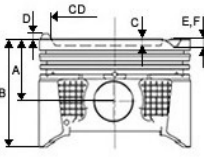







							
Motor /Engine	Ref. No. Kit 1	Ölçüler /Dimensions	Segman /Rings	Pim	Gömlek /Liner	Kit 2	Info
<p>ø79,00</p> <p>4 Cyl. Benzin 1600 cc</p> <p>GÜÇLENDİRİLMİŞ 1.6 EcoBoost</p> <p>.....-.....</p> <p>1.6 EcoBoost</p>	<p>18-2510440 STD</p> <p>18-2510440-30 STD</p> <p>18-2510443 0.50</p> <p>18-2510443-30 0.50</p> <p>18-2510448 1.00</p> <p>18-2510448-30 1.00</p>	<p>A = 28,650</p> <p>B = 54,000</p> <p>C = 5,100</p> <p>D = 6,350</p> <p>E = -3,190</p> <p>F = -2,430</p> <p>CD= 53,500</p> <p>Segman Taşıyıcı (Ring Carrier)</p> <p>Sert Anotlama (Hard Anodising)</p>	<p>RE43490000 -STD</p> <p>RE43490050 -0.50</p> <p>RE43490100 -1.00</p> <p>1,200 (500) NitB S</p> <p>1,200 (501) P</p> <p>2,000 (700) Cr P S</p>	<p>ø21,0 x 46,0</p>			
<p>ø79,00</p> <p>4 Cyl. Benzin 1600 cc</p> <p>1.6 EcoBoost KOL ARASI DÜZ</p> <p>.....-.....</p> <p>1.6 EcoBoost</p>	<p>18-2510460 STD</p> <p>18-2510463 0.50</p> <p>18-2510468 1.00</p>	<p>A = 29,700</p> <p>B = 57,500</p> <p>C = 5,200</p> <p>D = 6,320</p> <p>E = -3,200</p> <p>F = -2,500</p> <p>CD= 53,500</p> <p>Sert Anotlama (Hard Anodising)</p>	<p>RE23080000 -STD</p> <p>RE23080050 -0.50</p> <p>1,200 (500) NitB S</p> <p>1,500 (508) P</p> <p>2,000 (700) Nit S</p>	<p>ø21,0 x 57,0</p>			



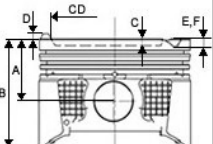









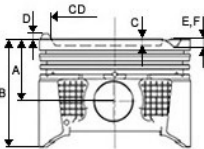



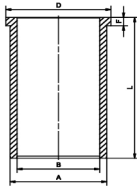
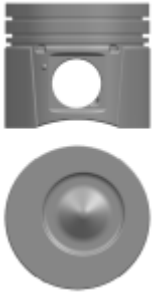

							
Motor /Engine	Ref. No. Kit 1	Ölçüler /Dimensions	Segman /Rings	Pim	Gömlek /Liner	Kit 2	Info
<p>ø79,00</p> <p>4 Cyl. Benzin 1600cc 115 123 PS 1.6 ZETEC S 2007 -</p> <p>Focus Mondeo</p>	<p>18-2510470 STD 18-2510473 0.50</p>	<p>A = 25,400 B = 53,400 C = 0,700 E = -3,800 F = -2,760 CD= 50,900</p>	<p>RE23080000 -STD RE23080050 -0.50</p> <p>1,200 (500) NitB S 1,500 (508) P 2,000 (700) Nit S</p>	<p>ø18,0 x 54,0</p>			
<p>ø79,00</p> <p>4 Cyl. Benzin 1596cc 100 115 PS CMAX 1.6 2003 -</p> <p>Focus 1,6i 16v</p>	<p>18-2510480 STD 18-2510483 0.50</p>	<p>A = 25,050 B = 48,050 C = 0,650 CD= 57,300</p>	<p>RE23080000 -STD RE23080050 -0.50</p> <p>1,200 (500) NitB S 1,500 (508) P 2,000 (700) Nit S</p>	<p>ø18,0 x 50,9</p>			



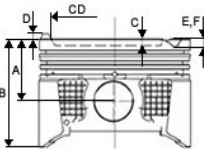



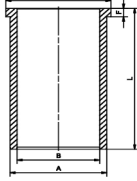
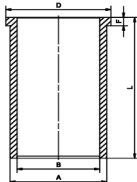

							
Motor /Engine	Ref. No. Kit 1	Ölçüler /Dimensions	Segman /Rings	Pim	Gömlek /Liner	Kit 2	Info
<p>ø79,00</p> <p>4 Cyl. Benzin 1597 cc 73 Kw (99 Ps) ZH16 Zetec s DOHC 16V EFI <u>1998 -....</u> Focus Ghia LX 16v</p>	<p>18-2510890 STD <i>18-2510890-20 STD (-0.20 mm)</i> 18-2510893 0.50 <i>18-2510893-20 0.50 (-0.20 mm)</i></p> 	<p>A = 25,050 B = 48,100</p>	<p>RE23080000 -STD RE23080050 -0.50</p> <p>1,200 (500) NitB S 1,500 (508) P 2,000 (700) Nit S</p>	<p>ø18,0 x 50,9</p>			<p>- 1,40 - 1,60</p>
<p>ø79,50</p> <p>4 Cyl. Diesel 1896/... cc 85 Kw 115 Ps 18:1 19:1 Turbo,LLK,8 Ventile AJM ATJ AUY BVK 1.&2.Sil <u>1988 -....</u> <i>1.&2.Sil A4/A6 1.9 TDI Turbo-LLK-8 Ventile GALAXY I 1.9 TDI ALHAMBRA 1.9 TDI GOLF IV BORA PASSAT SHARAN I 1.9 TDI</i></p>	<p>18-7050020 STD 18-7050023 0.50 18-7050028 1.00</p>	<p>A = 45,800 B = 69,800 C = 17,800 E = -1,300 F = -1,300 CD= 38,000</p>	<p>RE56160000 -STD RE56160050 -0.50 RE56160100 -1.00</p>	<p>ø26,0 x 66,0</p>			



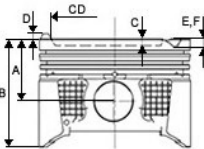





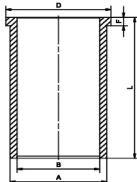

							
Motor /Engine	Ref. No. Kit 1	Ölçüler /Dimensions	Segman /Rings	Pim	Gömlek /Liner	Kit 2	Info
<p>ø79,50</p> <p>4 Cyl. Diesel 1896/... cc 85 Kw 115 Ps 18:1 19:1 Turbo,LLK,8 Ventile AJM ATJ AUY BVK 3.&4.Sil <u>1988 -....</u></p> <p>1.&2.Sil A4/A6 1.9 TDI Turbo-LLK-8 Ventile GALAXY I 1.9 TDI ALHAMBRA 1.9 TDI GOLF IV BORA PASSAT SHARAN I 1.9 TDI</p>	<p>18-7050030 STD 18-7050033 0.50 18-7050038 1.00</p>	<p>A = 45,800 B = 69,800 C = 17,800 E = -1,300 F = -1,300 CD= 38,000</p>	<p>RE56160000 -STD RE56160050 -0.50 RE56160100 -1.00</p>	<p>ø26,0 x 66,0</p>	<p>G83001548K_1</p> <p>A= 83,000 B= 78,810 D= 85,600 F= 5,100 H= 0,000 L= 154,800</p> 		
<p>ø79,97</p> <p>4 Cyl. Benzin 1598 cc 66/70 Kw (90/95 Ps) CVH LUC <u>1985 - 1992</u></p> <p>Escort 1.6 Fiesta XR2 Orion 1985-1992</p>	<p>18-2510710 STD 18-2510713 0.50 18-2510718 1.00</p>	<p>A = 36,590 B = 66,800 CD= 7,120</p> <p>Sac Plaka (Steel Support)</p> 	<p>RE23090000 -STD RE23090050 -0.50 RE23090100 -0.50</p> <p>1,600 (500) Cr 2,000 (508) P 4,000 (700) Cr P S</p>	<p>ø20,6 x 66,7</p>			

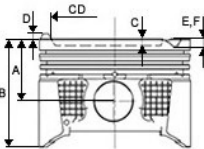





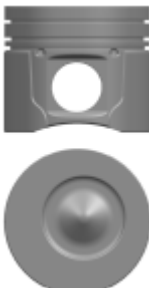
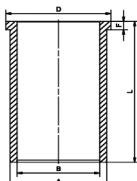

Motor /Engine	Ref. No. Kit 1	Ölçüler /Dimensions	Segman /Rings	Pim	Gömlek /Liner	Kit 2	Info
       							
ø80,00 4 Cyl. Diesel 1608 cc 39,5 Kw (54 Ps) 21,5:1 LTA LTB LTC D16 1998 - Fiesta D Escort D Orion D	18-2550900 STD 18-2550903 0.50	A = 46,700 B = 76,700 C = 1,800 E = -0,010	RE23100000 -STD RE23100050 -0.50 RE23100100 -1.00 2,000 (500) CrB Fe S 2,000 (501) P 3,000 (604) Cr P	ø24,0 x 62,0			1 Çentik Conta +0,43 +0,62 2 Çentik Conta +0,62 +0,68 3 Çentik Conta +0,68 +0,74 4 Çentik Conta +0,74 +0,80 5 Çentik Conta +0,80 +0,86
ø80,60 4 Cyl. Benzin 1796 cc 103/113 P ZH 1.8 ZETEC 1994 - Mondeo I 1.8 Escort V 1.8 Fiesta III 1.8 I Orion III 1.8 I	18-2510810 STD 18-2510813 0.50 18-2510818 1.00	A = 33,050 B = 57,100 Yag Püskürt. Oyugu (Oil Cut-Out)	RE23280000 -STD RE23280050 -0.50 RE23280100 -1.00 1,500 (500) Cr P IW 1,750 (508) P 3,000 (604) Cr P	ø20,6 x 63,5			
							



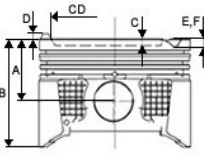





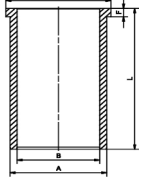

							
Motor /Engine	Ref. No. Kit 1	Ölçüler /Dimensions	Segman /Rings	Pim	Gömlek /Liner	Kit 2	Info
<p>ø81,30</p> <p>4 Cyl. Benzin, 1598 cm³ 55 kW (75 hp) LCR LCS LCT LSD LSE LSF E</p> <p><u>1986-1992</u></p> <p>Sierra 1.6 Laser 1.6</p>	<p>18-2510500 STD</p>	<p>A = 41,550 B = 71,550</p>	<p>RE23340000 -STD RE23340050 -0.50 RE23340100 -1.00</p> <p>1,600 (500) Cr P 2,000 (501) P 4,000 (700) Cr P S</p>	<p>ø24,0 x 68,8</p>			
<p>ø82,50</p> <p>4 Cyl. Diesel 1753cc 70 Kw (90 Ps) RWPA RWPC RWPD</p> <p><u>2006..2013</u></p> <p>Transit Connect 1.8 TDCI</p>	<p>18-2550190 STD 18-2550193 0.50</p>	<p>A = 45,650 B = 71,150 C = 12,400 CD= 45,200</p> <p>Segman Taşıyıcı (Ring Carrier)</p>	<p>RE23300000 -STD RE23300050 -0.50</p> <p>1,750 (500) Cr S IF 2,000 (508) P IFU 2,000 (604) Nit S</p>	<p>ø28,0 x 66,0</p>	<p>G82501460K_1</p> <p>A= 86,000 B= 81,800 D= 87,000 F= 5,000 H= 0,000 L= 146,000</p> 		

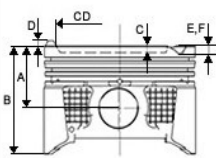







							
Motor /Engine	Ref. No. Kit 1	Ölçüler /Dimensions	Segman /Rings	Pim	Gömlek /Liner	Kit 2	Info
<p>ø82,50</p> <p>4 Cyl. Diesel, 1758 cm³ 66 85 kW (90 115 hp) F9DA F9DB <u>2001</u> -.... Focus 1.8 TDCi</p>	<p>18-2550200 STD 18-2550203 0.50</p>	<p>A = 45,700 B = 70,700 C = 14,050 CD= 41,520</p> <p>Segman Taşıyıcı (Ring Carrier)</p>	<p>RE23500000 -STD RE23500050 -0.50 RE23500100 -1.00</p> <p>2,500 (503) Cr S 2,000 (501) P 3,000 (604) Cr P</p>	<p>ø28,0 x 66,0</p>	<p>G82501460K_1</p> <p>A= 86,000 B= 81,800 D= 87,000 F= 5,000 H= 0,000 L= 146,000</p> 		
<p>ø82,50</p> <p>4 Cyl. Diesel 1800 cc 75 Ps C9DA C9DB C9DC <u>2002</u> -.... Focus I 1,8 TDDi Connect 1,8 TDDi</p>	<p>18-2550220 STD 18-2550220-20 STD (-0.20 mm) 18-2550223 0.50 18-2550223-20 0.50 (-0.20 mm) 18-2550228 1.00 18-2550228-20 1.00 (-0.20 mm)</p>	<p>A = 45,700 B = 70,900 C = 16,200 CD= 36,750</p> <p>Segman Taşıyıcı (Ring Carrier)</p>	<p>RE23500000 -STD RE23500050 -0.50 RE23500100 -1.00</p> <p>2,500 (503) Cr S 2,000 (501) P 3,000 (604) Cr P</p>	<p>ø28,0 x 66,0</p>	<p>G82501460K_1</p> <p>A= 86,000 B= 81,800 D= 87,000 F= 5,000 H= 0,000 L= 146,000</p> 	<p>1,36 mm conta +0,43 +0,68</p> <p>1,42 mm conta + 0,68 + 0,74</p> <p>1,52 mm conta + 0,74 + 0,86</p>	



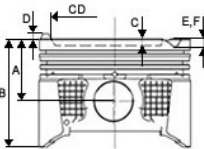





							
Motor /Engine	Ref. No. Kit 1	Ölçüler /Dimensions	Segman /Rings	Pim	Gömlek /Liner	Kit 2	Info
<p>ø82,50</p> <p>4 Cyl. Diesel, 1753 cm³ 44 kW (60 hp), 21,5:1</p> <p>RTA RTB RTC RTD RTE RTF RTG RTH RTJ</p> <p><u>1988-1994</u></p> <p><i>Fiesta D Escort D Orion D Mazda 121 1,8D</i></p>	<p>18-2550910 STD 18-2550913 0.50</p>	<p>A = 45,700 B = 73,700 C = 1,600</p> <p>Segman Taşıyıcı (Ring Carrier)</p>	<p>RE43150000 -STD RE43150050 -0.50 RE43150100 -1.00</p> <p>2,000 (500) Cr 2,000 (501) P 3,000 (604) Cr</p>	<p>ø26,0 x 69,0</p>	<p>G82501460K_1</p> <p>A= 86,000 B= 81,800 D= 87,000 F= 5,000 H= 0,000 L= 146,000</p> 		
<p>ø82,50</p> <p>4 Cyl. Diesel, 1753 cm³ 65 kW (88 hp)</p> <p>RFA RFB RFD RFK RFL RFM RFN RFS RFU</p> <p><u>1998 -....</u></p> <p><i>Mondeo Escort Sierra</i></p>	<p>18-2550920 STD 18-2550923 0.50</p>	<p>A = 45,650 B = 75,800 C = 1,500</p> <p>Segman Taşıyıcı (Ring Carrier)</p>	<p>RE23500000 -STD RE23500050 -0.50 RE23500100 -1.00</p> <p>2,500 (503) Cr S 2,000 (501) P 3,000 (604) Cr P</p>	<p>ø26,0 x 69,0</p>	<p>G82501460K_1</p> <p>A= 86,000 B= 81,800 D= 87,000 F= 5,000 H= 0,000 L= 146,000</p> 		

							
Motor /Engine	Ref. No. Kit 1	Ölçüler /Dimensions	Segman /Rings	Pim	Gömlek /Liner	Kit 2	Info
<p>ø82,50</p> <p>4 Cyl. Diesel 1800 cc 90 Ps ECOTORQ (Cooling Channel) 1.8 TDCi <u>2002 -.....</u> Connect 1,8 TDCi</p>	<p>18-2581880 STD 18-2581883 0.50 18-2581884 0.60 18-2581888 1.00</p> 	<p>A = 45,500 B = 70,700 C = 14,100 CD= 41,500</p> <p>Segman Taşıyıcı (Ring Carrier)</p> <p>Yag Galerisi (Oil Gallery)</p>	<p>RE23500000 -STD RE23500050 -0.50 RE23500100 -1.00</p> <p>2,500 (503) Cr S 2,000 (501) P 3,000 (604) Cr P</p>	<p>ø28,0 x 66,0</p>	<p>G82501460K_1</p> <p>A= 86,000 B= 81,800 D= 87,000 F= 5,000 H= 0,000 L= 146,000</p> 		<p>1,36 mm conta +0,43 +0,68</p> <p>1,42 mm conta +0,68 +0,74</p> <p>1,52 mm conta +0,74 +0,86</p>
<p>ø82,50</p> <p>4 Cyl. Diesel 1753 cc 81 Kw (110 Ps) 18,5:1 KKDA DURATORQ 1800cc <u>2007 -.....</u> Connect 1,8 TDCi</p>	<p>18-2582110 STD 18-2582110-20 STD (-0.20 mm) 18-2582113 0.50 18-2582113-20 0.50 (-0.20 mm)</p> 	<p>A = 45,650 B = 71,150 C = 12,470 CD= 45,290</p> <p>Segman Taşıyıcı (Ring Carrier)</p> <p>Yag Galerisi (Oil Gallery)</p>	<p>RE23300000 -STD RE23300050 -0.50</p> <p>1,750 (500) Cr S IF 2,000 (508) P IFU 2,000 (604) Nit S</p>	<p>ø28,0 x 66,0</p>	<p>G82501460K_1</p> <p>A= 86,000 B= 81,800 D= 87,000 F= 5,000 H= 0,000 L= 146,000</p> 		<p>1,36 mm conta +0,43 +0,68</p> <p>1,42 mm conta +0,68 +0,74</p> <p>1,52 mm conta +0,74 +0,86</p>

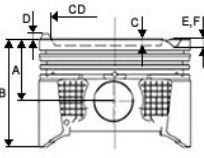





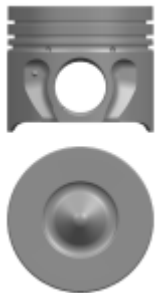

							
Motor /Engine	Ref. No. Kit 1	Ölçüler /Dimensions	Segman /Rings	Pim	Gömlek /Liner	Kit 2	Info
<p>ø84,01</p> <p>4 Cyl. Diesel 1996 cc 96 Kw 130 Ps Panther 2.0L I4 EcoBlue</p> <p>.....</p> <p>Tourneo Custom Transit Custom</p>	<p>18-2594270 STD 18-2594273 0.50</p>	<p>A = 48,400 B = 73,200 C = 14,400 E = -0,060 CD= 48,230</p> <p>Segman Taşıyıcı (Ring Carrier)</p> <p>Yag Galerisi (Oil Gallery)</p> <p>Burc (Bushing)</p>	<p>RE35060000 -STD RE35060050 -0.50</p> <p>2,000 () 2,000 () 2,000 ()</p>	<p>ø30,0 x 63,7</p>	<p>G84001460K_1</p> <p>A= 87,000 B= 83,300 D= 88,500 F= 5,000 H= 0,000 L= 146,000</p> 		
<p>ø84,80</p> <p>4 Cyl. Benzin 1998 cc 96 100 KW 130 EDDC EDBC EDBA CAA 1996 -....</p> <p>Mondeo II 2.0 I Focus I 2.0</p>	<p>18-2510820 STD 18-2510823 0.50</p>	<p>A = 32,930 B = 56,930</p>	<p>RE23180000 -STD RE23180050 -0.50</p> <p>1,500 (500) Cr P IF 1,750 (508) P 3,000 (700) Cr S P</p>	<p>ø20,6 x 63,5</p>			



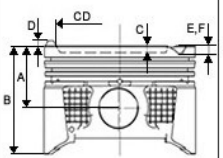



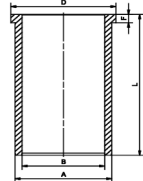
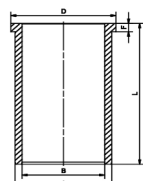

Motor /Engine	Ref. No. Kit 1	Ölçüler /Dimensions	Segman /Rings	Pim	Gömlek /Liner	Kit 2	Info
							
ø85,00 4 Cyl. Diesel 1997/1998 cc 79/80/81/100Kw 90/107/109Ps 110/136 Ps DW10ATED TD10ATED DW10TD Euro 3 G6DB RHS RHW RHX RHY RHZ D420 4T <u>1998 -</u> 2.0 HDI 206/306/307/406 Boxer Partner Expet C5 Jumpy Xsara Scudo 2.0JTD Cmax Focus II Grand Vitara C30 C70 S40/80 II V50 V70 III TDI	18-7550900 STD 18-7550900-20 STD (-0.20 mm) 18-7550900-40 STD (-0.40 mm) 18-7550903 0.50 18-7550904 0.60	A = 46,750 B = 80,750 C = 18,300 E = -1,000 CD= 38,000 Segman Taşıyıcı (Ring Carrier) Yag Püskürt. Oyugu (Oil Cut-Out)	RE47440000 -STD RE47440060 -0.60 3,500 (505) Cr P 2,000 (501) P IFU 3,000 (604) Cr P	ø28,0 x 70,0			1,25 mm conta +0,55 + 0,60 1,30 mm conta +0,61 +0,65 1,35 mm conta +0,66 +0,70 1,40 mm conta +0,71 +0,75
ø85,00 4 Cyl. Diesel, 1997 cm ³ 62 88 kW (84 120 PS) DW10BTED4 <u>1999 - 2007</u> (2.0HDI) Berlingo C4 16V C4 GrandPicasso 16V C4 Picasso 16V C5 16V C8 16V Jumpy 6V C-Max Kuga 307 16V 307 CC 16V 308 16V 407 16V 508	18-7551920 STD 18-7551924 0.60	A = 46,705 B = 80,705 C = 15,400 E = -0,520 CD= 44,800 Segman Taşıyıcı (Ring Carrier) Yag Galerisi (Oil Gallery) Yag Püskürt. Oyugu (Oil Cut-Out)	RE47440000 -STD RE47440060 -0.60 3,500 (505) Cr P 2,000 (501) P IFU 3,000 (604) Cr P	ø28,0 x 70,0			



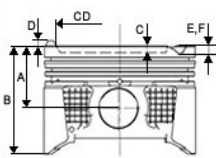



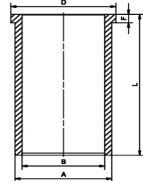

							
Motor /Engine	Ref. No. Kit 1	Ölçüler /Dimensions	Segman /Rings	Pim	Gömlek /Liner	Kit 2	Info
<p>ø85,00</p> <p>4 Cyl. Diesel 1997 cc 163PS DW10CTED4 <u>2009 -</u></p> <p>3008 5008 C4 C5 III 2.0 HDI DS4 KUGA</p>	<p>18-7592960 STD 18-7592964 0.60</p>	<p>A = 46,705 B = 74,705 C = 13,710 E = -0,455 CD= 50,400</p> <p>Segman Taşıyıcı (Ring Carrier)</p> <p>Yag Galerisi (Oil Gallery)</p> <p>Yag Püskürt. Oyugu (Oil Cut-Out)</p>	<p>RE47770000 -STD RE47770060 -0.60</p> <p>2,000 () 2,000 () P 2,000 ()</p>	<p>ø30,0 x 68,0</p>			
<p>ø86,00</p> <p>4 Cyl. Benzin, 1998 cm³ 88 92 kW (120 125 hp) 10,3:1 N8A N8B N8C N8D N9A N9B N9C N9D N9E N9F NES <u>1989-1994</u></p> <p>Sierra Scorpio Galaxy Granada Sapphire Transit</p>	<p>18-2510410 STD 18-2510413 0.50</p>	<p>A = 32,270 B = 62,270 E = -2,000</p> <p>Sac Plaka (Steel Support)</p>	<p>RE23410000 -STD RE23410050 -0.50</p> <p>1,600 (500) Cr P IF 1,750 (508) P 3,000 (700) Cr P S</p>	<p>ø20,6 x 63,5</p>			



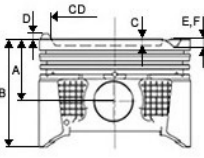





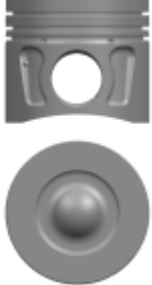
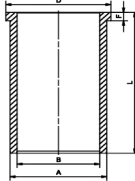
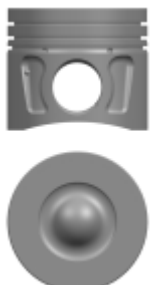

							
Motor /Engine	Ref. No. Kit 1	Ölçüler /Dimensions	Segman /Rings	Pim	Gömlek /Liner	Kit 2	Info
<p>ø86,00</p> <p>4 Cyl. Benzin, 1998 cm³ 85 kW (115 hp), 8,6:1 N9K N9L NSD NSE NSF <u>4/1994..</u></p> <p><i>Sierra Scorpio Tourneo</i></p>	<p>18-2510510 STD 18-2510513 0.50</p>	<p>A = 32,270 B = 62,270 C = 1,200 E = -1,200 CD= 60,000</p>	<p>RE23410000 -STD RE23410050 -0.50</p> <p>1,600 (500) Cr P IF 1,750 (508) P 3,000 (700) Cr P S</p>	<p>ø20,6 x 63,4</p>			
<p>ø86,00</p> <p>4 Cyl. Diesel 1998 cc 125 Ps V185 Duratorq TDC 2000.. CD132 Duratorq TDCI 2001. <u>2000 -</u></p> <p><i>Transit 2.0 TDCI 2000> Mondeo 2.0 TDCI 2001></i></p>	<p>18-2583330 STD 18-2583331 0.25 18-2583333 0.50</p>	<p>A = 47,700 B = 74,100 C = 15,200 CD= 43,300</p> <p>Segman Taşıyıcı (Ring Carrier)</p> <p>Yag Galerisi (Oil Gallery)</p>	<p>RE23350000 -STD RE23350025 -0.25 RE23350050 -0.50</p> <p>2,000 (500) Cr P IF 2,000 (508) P 2,000 (604) Nit S</p>	<p>ø30,0 x 66,9</p>			<p>1,10 mm conta +0,43 +0,52</p> <p>1,15 mm conta +0,52 +0,57</p> <p>1,20 mm conta +0,57 +0,62</p>

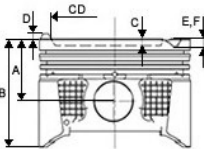





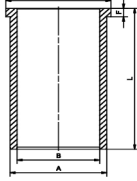





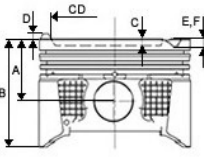





Motor /Engine	Ref. No. Kit 1	Ölçüler /Dimensions	Segman /Rings	Pim	Gömlek /Liner	Kit 2	Info
							
ø86,01 4 Cyl. Diesel 1998 cc 75/85/90/100 Ps 18,2:1 V185 Duratorq TDI CD132 Duratorq TDI 2000/2001 - Turbo-Intercooler Mondeo III 2,0 TDCi Transit 2,0 TDCi	18-2550340 STD 18-2550340-20 STD (-0.20 mm) 18-2550341 0.25 18-2550343 0.50 18-2550343-20 0.50 (-0.20 mm)	A = 47,580 B = 73,980 C = 16,500 CD= 40,200 Segman Taşıyıcı (Ring Carrier)	RE23350000 -STD RE23350025 -0.25 RE23350050 -0.50 2,000 (500) Cr P IF 2,000 (508) P 2,000 (604) Nit S	ø30,0 x 66,9	G86011670K_1 A= 89,000 B= 85,310 D= 90,500 F= 5,000 H= 0,000 L= 167,000 	1,10 mm conta +0,43 +0,52 1,15 mm conta +0,52 +0,57 1,20 mm conta +0,57 +0,62	
ø86,01 4 Cyl. Diesel 2200 cc 100 Ps V347 Duratorq 2003.. Transit 2.2 TDCi	18-2582340 STD 18-2582340-20 STD (-0.20 mm) 18-2582341 0.25 18-2582343 0.50 18-2582343-20 0.50 (-0.20 mm)	A = 43,420 B = 69,820 C = 15,850 CD= 46,900 Segman Taşıyıcı (Ring Carrier)	RE23350000 -STD RE23350025 -0.25 RE23350050 -0.50 2,000 (500) Cr P IF 2,000 (508) P 2,000 (604) Nit S	ø30,0 x 66,9	G86011560K_1 A= 89,000 B= 85,310 D= 90,500 F= 5,000 H= 0,000 L= 156,000 	1,10 mm conta +0,43 +0,52 1,15 mm conta +0,52 +0,57 1,20 mm conta +0,57 +0,62	



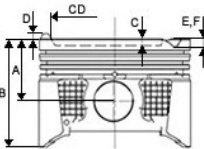





Motor /Engine	Ref. No. Kit 1	Ölçüler /Dimensions	Segman /Rings	Pim	Gömlek /Liner	Kit 2	Info
							
ø86,01 4 Cyl. Diesel 2198/2200 cc 100/120/130/150 Ps 17,5:1 QWFB/V347 Duratorq Euro 4 Duratorq/V347 D CD132 Duratorq TDCI 2003/2008.. Common Rail Transit 2.2 TDCI Yeni Jumper 2.2 HDI Ducato 100 Multijet Yeni Boxer HDI Mondeo 2.2 TDCI Transit 2.2 TDCI	18-2582350 STD 18-2582350-20 STD (-0.20 mm) 18-2582351 0.25 18-2582353 0.50 18-2582353-20 0.50 (-0.20 mm)	A = 43,420 B = 69,820 C = 15,850 CD= 46,900 Segman Taşıyıcı (Ring Carrier) Yag Galerisi (Oil Gallery)	RE23350000 -STD RE23350025 -0.25 RE23350050 -0.50 2,000 (500) Cr P IF 2,000 (508) P 2,000 (604) Nit S	ø30,0 x 66,9	G86011560K_1 A= 89,000 B= 85,310 D= 90,500 F= 5,000 H= 0,000 L= 156,000 	1,10 mm conta +0,38 +0,47 1,20 mm conta +0,48 +0,58 1,30 mm conta + 0,59 +0,68	
ø86,01 4 Cyl. Diesel 1988 cc 125 Ps 19:1 CD132 V185 X400 2003.. Mondeo 2.0 TDCI Transit 300 SF Journey Deluxe	18-2582370 STD 18-2582371 0.25 18-2582373 0.50	A = 47,700 B = 74,100 C = 14,800 CD= 48,100 Segman Taşıyıcı (Ring Carrier) Yag Galerisi (Oil Gallery)	RE23350000 -STD RE23350025 -0.25 RE23350050 -0.50 2,000 (500) Cr P IF 2,000 (508) P 2,000 (604) Nit S	ø30,0 x 66,9		1,10 mm conta +0,43 +0,52 1,15 mm conta +0,52 +0,57 1,20 mm conta +0,57 +0,62	



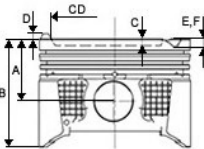



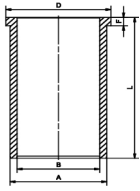

							
Motor /Engine	Ref. No. Kit 1	Ölçüler /Dimensions	Segman /Rings	Pim	Gömlek /Liner	Kit 2	Info
<p>ø86,01</p> <p>4 Cyl. Diesel 2198/2179 cc 155 PS 74 Kw (100 Ps) 15,5:1 2.2L Duratorq/HDI (CUFF,CUF5,CVRS,UYRG)) <u>2002 -</u></p> <p>Euro 5 TRANSİT 2.2 (YENİ) Boxer 2.2L</p>	<p>18-2582420 STD 18-2582420-20 STD (-0.20 mm) 18-2582421 0.25 18-2582423 0.50 18-2582423-20 0.50 (-0.20 mm)</p> 	<p>A = 48,420 B = 74,820 C = 18,230 CD= 49,040</p> <p>Segman Taşıyıcı (Ring Carrier)</p> <p>Yag Galerisi (Oil Gallery)</p> <p>Yag Püskürt. Oyugu (Oil Cut-Out)</p>	<p>RE23350000 -STD RE23350025 -0.25 RE23350050 -0.50</p> <p>2,000 (500) Cr P IF 2,000 (508) P 2,000 (604) Nit S</p>	<p>ø30,0 x 66,9</p>	<p>G86011650K_1</p> <p>A= 89,000 B= 85,310 D= 90,500 F= 5,000 H= 0,000 L= 165,000</p> 		
<p>ø86,01</p> <p>4 Cyl. Diesel 2198 cc 125PS/135PS 15,5:1 Euro 5 2.2L Duratorq (CYFS,U5R6) <u>2006 - 2011</u></p> <p>Transit 330S Transit 350M/350MF Transit 370M-410L-460 ED</p>	<p>18-2582600 STD 18-2582600-20 STD (-0.20 mm) 18-2582601 0.25 18-2582603 0.50 18-2582603-20 0.50 (-0.20 mm)</p> 	<p>A = 48,420 B = 74,820 C = 15,850 CD= 46,900</p> <p>Segman Taşıyıcı (Ring Carrier)</p> <p>Yag Galerisi (Oil Gallery)</p> <p>Yag Püskürt. Oyugu (Oil Cut-Out)</p>	<p>RE23350000 -STD RE23350025 -0.25 RE23350050 -0.50</p> <p>2,000 (500) Cr P IF 2,000 (508) P 2,000 (604) Nit S</p>	<p>ø30,0 x 66,9</p>			



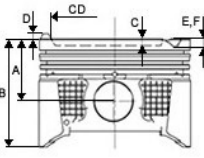
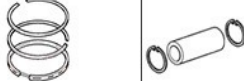



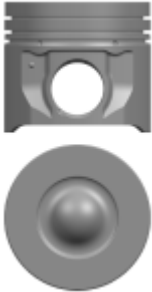

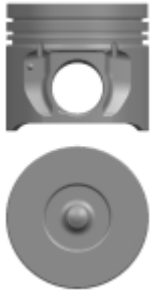
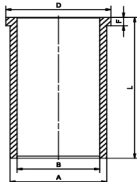
							
Motor /Engine	Ref. No. Kit 1	Ölçüler /Dimensions	Segman /Rings	Pim	Gömlek /Liner	Kit 2	Info
<p>ø86,01</p> <p>4 Cyl. Diesel 2198/2179 cc 155 PS 74 Kw (100 Ps) 15,5:1 2.2L Duratorg/HDI (CUFF,CUF5,CVRS,UYRG)) <u>2002 -</u></p> <p><i>Euro 5 Boxer 2.2L</i></p>	<p>18-7592950 STD <i>18-7592950-20 STD (-0.20 mm)</i></p> <p>18-7592951 0.25 18-7592953 0.50 <i>18-7592953-20 0.50 (-0.20 mm)</i></p>	<p>A = 48,420 B = 74,820 C = 18,230 CD= 49,040</p> <p>Segman Taşıyıcı (Ring Carrier)</p> <p>Yag Galerisi (Oil Gallery)</p> <p>Yag Püskürt. Oyugu (Oil Cut-Out)</p>	<p>RE23350000 -STD RE23350025 -0.25 RE23350050 -0.50</p> <p>2,000 (500) Cr P IF 2,000 (508) P 2,000 (604) Nit S</p>	<p>ø30,0 x 66,9</p>	<p>G86011650K_1</p> <p>A= 89,000 B= 85,310 D= 90,500 F= 5,000 H= 0,000 L= 165,000</p> 		
<p>ø87,50</p> <p>4 Cyl. Benzin 2000cc 145 Ps HE DURATEC <u>2001....</u></p> <p><i>Mondeo 2,0 Mazda 6 2,0i 16v Atenza 2,0i 16v</i></p>	<p>18-2510310 STD 18-2510313 0.50</p>	<p>A = 28,400 B = 51,000 C = 0,350 CD= 75,400</p>	<p>RE23470000 -STD RE23470050 -0.50</p> <p>1,200 (500) Cr4B S 1,200 (501) P IFU 2,500 (700) Cr P S</p>	<p>ø21,0 x 60,0</p>			



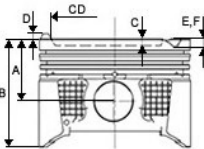



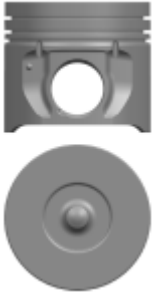
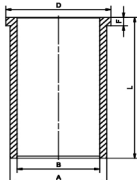
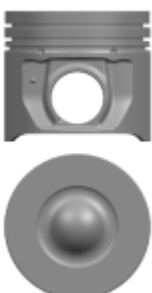
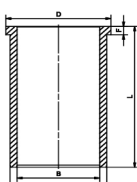

							
Motor /Engine	Ref. No. Kit 1	Ölçüler /Dimensions	Segman /Rings	Pim	Gömlek /Liner	Kit 2	Info
<p>ø87,52</p> <p>4 Cyl. Benzin 1999 cc 176/177/179 KW 239/240/241/243 PS 2.0 Ecoboost TPBA 204PT Euro 5 2.0 4x4 B 4204 T7 T5</p> <p><u>2010 - 2015</u></p> <p>2,0 EcoBoost Discovery Sport L550 Range R.Evoque Cabriolet L538 Freelander 2 L359/LF S60 II 134/124 V60 155/157 V70 III 135 XC60 156</p>	<p>18-2510320 STD 18-2510323 0.50</p>	<p>A = 32,800 B = 53,800 D = 2,190</p> <p>Sert Anotlama (Hard Anodising)</p>	<p>RK25187500010 -STD RK25187500013 -0.50</p> <p>1,200 () Cr S P 1,200 () S P 2,000 () Nit S</p>	<p>ø22,5 x 56,0</p>			
<p>ø87,65</p> <p>4 Cyl. Benzin 1576 cc 50/51,5/53,5 Kw LC</p> <p><u>1970 - 1982</u></p> <p>Taunus Capri Cortina Transit</p>	<p>18-2510080 STD 18-2510083 0.50</p>	<p>A = 39,970 B = 71,970</p> <p>Sac Plaka (Steel Support)</p>	<p>RE23230000 -STD RE23230020 -0.20 RE23230040 -0.40 RE23230050 -0.50 RE23230051 -0.508 RE23230100 -1.00 RE23230102 -1.016</p> <p>2,000 (500) CrB Fe S 2,500 (501) P 4,000 (700) Cr P S</p>	<p>ø24,0 x 73,0</p>			



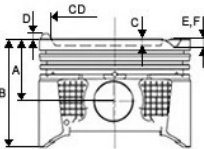



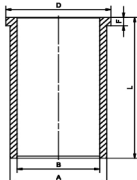
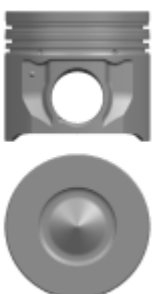
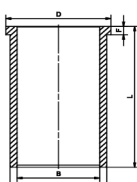

							
Motor /Engine	Ref. No. Kit 1	Ölçüler /Dimensions	Segman /Rings	Pim	Gömlek /Liner	Kit 2	Info
<p>ø87,65</p> <p>4 Cyl. Benzin 1576 cc 53/53,5/64,5 Kw HC <u>1970 - 1981</u></p> <p><i>Taurus Capri Escort Cortina Granada</i></p>	<p>18-2510090 STD 18-2510093 0.50 18-2510098 1.00</p>	<p>A = 41,100 B = 73,100</p> <p>Sac Plaka (Steel Support)</p>	<p>RE23230000 -STD RE23230020 -0.20 RE23230040 -0.40 RE23230050 -0.50 RE23230051 -0.508 RE23230100 -1.00 RE23230102 -1.016</p> <p>2,000 (500) CrB Fe S 2,500 (501) P 4,000 (700) Cr P S</p>	<p>ø24,0 x 73,0</p>			
<p>ø88,00</p> <p>4 Cyl. Diesel 1975/1987/1990 cc 32/40/42/44 Kw (49/54/5760 Ps) VTA XDP4.88 XD 4.88 XD 88 XD P 4.88/4.88/88 <u>1987</u></p> <p><i>504 1.9D 404 1.9D 404 2.0D/504 2.0D J 7 1.9 D Granada 2.0D</i></p>	<p>18-7550930 STD</p>	<p>A = 58,700 B = 95,700 C = 1,950</p>	<p>RE47140000 -STD</p> <p>2,000 (500) Cr 2,000 (501) P 2,000 (508) P 4,500 (604) P</p>	<p>ø28,0 x 72,0</p>			



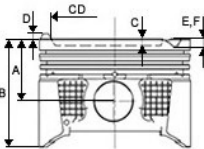



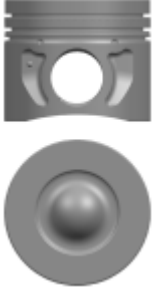
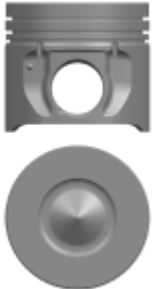

							
Motor /Engine	Ref. No. Kit 1	Ölçüler /Dimensions	Segman /Rings	Pim	Gömlek /Liner	Kit 2	Info
<p>ø89,90</p> <p>4 Cyl. Diesel 2402cc 66 Kw (90 PS) 19:1 D2FA D2FB D2FE D4FA <u>2000 - 2003</u> Transit 2,4 Di Transit 2,4 TDE</p>	<p>18-2550230 STD 18-2550230-20 STD (-0.20 mm) 18-2550231 0.25 18-2550233 0.50 18-2550238 1.00</p>	<p>A = 53,500 B = 80,500 C = 17,000 CD= 41,050</p> <p>Segman Taşıyıcı (Ring Carrier)</p>	<p>RE23170000 -STD RE23170025 -0.25 RE23170050 -0.50 RE23170100 -1.00</p> <p>2,500 (503) Cr P 2,000 (501) P IF 3,000 (604) Cr P</p>	<p>ø32,0 x 66,2</p>			<p>1,10 mm conta +0,30 +0,40</p> <p>1,15 mm conta +0,40 +0,45</p> <p>1,20 mm conta +0,45 +0,50</p>
<p>ø89,90</p> <p>4 Cyl. Diesel 2402 cc 66 Kw (90 Ps) HEFA HFFA <u>2003 - 2006</u> Transit 300S Transit 330S</p>	<p>18-2550240 STD 18-2550240-20 STD (-0.20 mm) 18-2550241 0.25 18-2550243 0.50 18-2550243-20 0.50 (-0.20 mm)</p>	<p>A = 53,500 B = 80,500 C = 17,240 CD= 41,050</p> <p>Segman Taşıyıcı (Ring Carrier)</p>	<p>RE23520000 -STD RE23520025 -0.25 RE23520050 -0.50</p> <p>2,000 (500) Cr P 2,000 (508) P 2,000 (604) Nit S</p>	<p>ø32,0 x 66,2</p>	<p>G89911650K_1</p> <p>A= 92,500 B= 89,210 D= 95,500 F= 3,000 H= 0,000 L= 165,000</p>		<p>1,10 mm conta +0,30 +0,40</p> <p>1,15 mm conta +0,40 +0,45</p> <p>1,20 mm conta +0,45 +0,50</p>



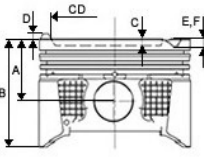



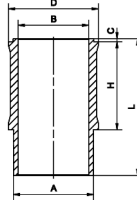

							
Motor /Engine	Ref. No. Kit 1	Ölçüler /Dimensions	Segman /Rings	Pim	Gömlek /Liner	Kit 2	Info
<p>ø89,90</p> <p>4 Cyl. Diesel 2400 cc 115 143 Ps SXFA SVFB V 348 DURATORQ (Cooling Channel) <u>2004-2013</u> Transit 2,4 TDi</p>	<p>18-2582330 STD <i>18-2582330-20 STD (-0.20 mm)</i> 18-2582331 0.25 18-2582333 0.50 <i>18-2582333-20 0.50 (-0.20 mm)</i></p> 	<p>A = 53,500 B = 80,500 C = 16,300 CD= 49,000</p> <p>Segman Taşıyıcı (Ring Carrier)</p> <p>Yag Galerisi (Oil Gallery)</p> <p>Yag Püskürt. Oyugu (Oil Cut-Out)</p>	<p>RE23520000 -STD RE23520025 -0.25 RE23520050 -0.50</p> <p>2,000 (500) Cr P 2,000 (508) P 2,000 (604) Nit S</p>	<p>ø32,0 x 71,1</p>	<p>G89911650K_1</p> <p>A= 92,500 B= 89,210 D= 95,500 F= 3,000 H= 0,000 L= 165,000</p> 		<p>1,10 mm conta +0,30 +0,40</p> <p>1,15 mm conta +0,40 +0,45</p> <p>1,20 mm conta +0,45 +0,50</p>
<p>ø89,90</p> <p>4 Cyl. Diesel 2402 cc 88 Kw (120 Ps) 19:1 D4FA DURATORQ Cooling Channel <u>2000 - 2003</u> Transit 2,4 TDi</p>	<p>18-2582440 STD <i>18-2582440-20 STD (-0.20 mm)</i> 18-2582441 0.25 18-2582443 0.50</p> 	<p>A = 53,500 B = 80,500 C = 17,240 CD= 40,400</p> <p>Segman Taşıyıcı (Ring Carrier)</p> <p>Yag Galerisi (Oil Gallery)</p>	<p>RE23170000 -STD RE23170025 -0.25 RE23170050 -0.50 RE23170100 -1.00</p> <p>2,500 (503) Cr P 2,000 (501) P IF 3,000 (604) Cr P</p>	<p>ø32,0 x 71,1</p>	<p>G89911650K_1</p> <p>A= 92,500 B= 89,210 D= 95,500 F= 3,000 H= 0,000 L= 165,000</p> 		<p>1,10 mm conta +0,30 +0,40</p> <p>1,15 mm conta +0,40 +0,45</p> <p>1,20 mm conta +0,45 +0,50</p>

							
Motor /Engine	Ref. No. Kit 1	Ölçüler /Dimensions	Segman /Rings	Pim	Gömlek /Liner	Kit 2	Info
<p>ø89,90</p> <p>4 Cyl. Diesel 2402 cc 100 120 Ps 19:1 HFFA RBFA V184 Tdi (Cooling Channel) <u>2003 - 2006</u> Transit 2,4 TDi</p>	<p>18-2582550 STD 18-2582550-20 STD (-0.20 mm) 18-2582551 0.25 18-2582553 0.50 18-2582553-20 0.50 (-0.20 mm)</p> 	<p>A = 53,500 B = 80,500 C = 17,240 CD= 40,400</p> <p>Segman Taşıyıcı (Ring Carrier)</p> <p>Yag Galerisi (Oil Gallery)</p> <p>Yag Püskürt. Oyugu (Oil Cut-Out)</p>	<p>RE23520000 -STD RE23520025 -0.25 RE23520050 -0.50</p> <p>2,000 (500) Cr P 2,000 (508) P 2,000 (604) Nit S</p>	<p>ø32,0 x 71,1</p>	<p>G89911650K_1</p> <p>A= 92,500 B= 89,210 D= 95,500 F= 3,000 H= 0,000 L= 165,000</p> 		<p>1,10 mm conta +0,30 +0,40</p> <p>1,15 mm conta +0,40 +0,45</p> <p>1,20 mm conta +0,45 +0,50</p>
<p>ø89,91</p> <p>4 Cyl. Diesel 2400 cc 100 Ps V348 TDCI <u>2006 -....</u> Transit 2,4 TDI 2006></p>	<p>18-2550250 STD 18-2550250-20 STD (-0.20 mm) 18-2550251 0.25 18-2550253 0.50 18-2550253-20 0.50 (-0.20 mm)</p> 	<p>A = 53,500 B = 80,500 C = 16,300 CD= 49,000</p> <p>Segman Taşıyıcı (Ring Carrier)</p>	<p>RE23520000 -STD RE23520025 -0.25 RE23520050 -0.50</p> <p>2,000 (500) Cr P 2,000 (508) P 2,000 (604) Nit S</p>	<p>ø32,0 x 66,2</p>	<p>G89911650K_1</p> <p>A= 92,500 B= 89,210 D= 95,500 F= 3,000 H= 0,000 L= 165,000</p> 		

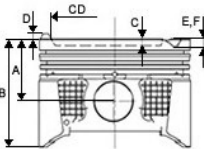







							
Motor /Engine	Ref. No. Kit 1	Ölçüler /Dimensions	Segman /Rings	Pim	Gömlek /Liner	Kit 2	Info
<p>ø89,91</p> <p>4 Cyl. Diesel 2400 cc 125 Ps V184 TDI 2003 -.... Duratorq Transit 2.4 TDI</p>	<p>18-2582390 STD 18-2582390-20 STD (-0.20 mm) 18-2582391 0.25 18-2582393 0.50 18-2582393-20 0.50 (-0.20 mm)</p> 	<p>A = 53,500 B = 80,500 C = 17,240 CD= 40,400</p> <p>Segman Taşıyıcı (Ring Carrier)</p> <p>Yag Galerisi (Oil Gallery)</p> <p>Yag Püskürt. Oyugu (Oil Cut-Out)</p>	<p>RE23520000 -STD RE23520025 -0.25 RE23520050 -0.50</p> <p>2,000 (500) Cr P 2,000 (508) P 2,000 (604) Nit S</p>	<p>ø32,0 x 71,1</p>	<p>G89911650K_1</p> <p>A= 92,500 B= 89,210 D= 95,500 F= 3,000 H= 0,000 L= 165,000</p> 		
<p>ø89,91</p> <p>4 Cyl. Diesel 2400 cc 135 Ps V184 TDCI 2.4 Duratorq Transit 2.4 TDCI</p>	<p>18-2582570 STD 18-2582571 0.25 18-2582573 0.50</p> 	<p>A = 53,500 B = 80,500 C = 15,620 CD= 47,100</p> <p>Segman Taşıyıcı (Ring Carrier)</p> <p>Yag Galerisi (Oil Gallery)</p>	<p>RE23520000 -STD RE23520025 -0.25 RE23520050 -0.50</p> <p>2,000 (500) Cr P 2,000 (508) P 2,000 (604) Nit S</p>	<p>ø32,0 x 71,1</p>	<p>G89911650K_1</p> <p>A= 92,500 B= 89,210 D= 95,500 F= 3,000 H= 0,000 L= 165,000</p> 		



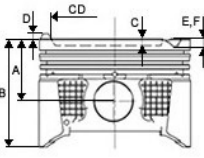





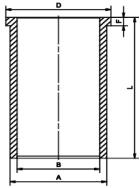

							
Motor /Engine	Ref. No. Kit 1	Ölçüler /Dimensions	Segman /Rings	Pim	Gömlek /Liner	Kit 2	Info
<p>ø89,91</p> <p>5 Cyl. Diesel 3200cc 200 HP SAFA Duratorq SAFB Duratorq V348 TDCI <u>2006..</u></p> <p>Transit 3,2 Ranger 3.2</p>	<p>17-2582580 STD</p> <p>17-2582580-20 STD (-0.20 mm)</p> <p>17-2582581 0.25</p> <p>17-2582583 0.50</p> <p>17-2582583-20 0.50 (-0.20 mm)</p> <div data-bbox="336 842 488 1128" style="text-align: center;">  </div>	<p>A = 48,220 B = 75,220 C = 16,700 CD= 50,200</p> <p>Segman Taşıyıcı (Ring Carrier)</p> <p>Yag Galerisi (Oil Gallery)</p> <p>Yag Püskürt. Oyugu (Oil Cut-Out)</p>	<p>RE23520000 -STD RE23520025 -0.25 RE23520050 -0.50</p> <p>2,000 (500) Cr P 2,000 (508) P 2,000 (604) Nit S</p>	<p>ø32,0 x 74,1</p>			
<p>ø89,91</p> <p>4 Cyl. Diesel 2400 cc 130 Ps RCFA V184 Dti (Cooling Channel) <u>2003 -....</u></p> <p>Transit 2,4 TDi</p>	<p>18-2582660 STD</p> <p>18-2582660-20 STD (-0.20 mm)</p> <p>18-2582661 0.25</p> <p>18-2582663 0.50</p> <p>18-2582663-20 0.50 (-0.20 mm)</p> <div data-bbox="336 1697 488 1984" style="text-align: center;">  </div>	<p>A = 53,500 B = 80,500 C = 15,620 CD= 47,100</p> <p>Segman Taşıyıcı (Ring Carrier)</p> <p>Yag Galerisi (Oil Gallery)</p> <p>Yag Püskürt. Oyugu (Oil Cut-Out)</p>	<p>RE23520000 -STD RE23520025 -0.25 RE23520050 -0.50</p> <p>2,000 (500) Cr P 2,000 (508) P 2,000 (604) Nit S</p>	<p>ø32,0 x 71,1</p>			<p>1,10 mm conta +0,30 +0,40</p> <p>1,15 mm conta +0,40 +0,45</p> <p>1,20 mm conta +0,45 +0,50</p>

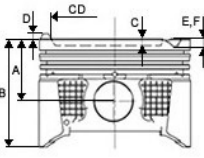
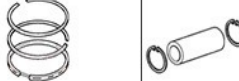

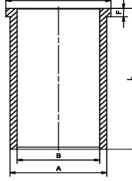

							
Motor /Engine	Ref. No. Kit 1	Ölçüler /Dimensions	Segman /Rings	Pim	Gömlek /Liner	Kit 2	Info
<p>ø90,00</p> <p>V 6 Benzin, 2293 cm³ 79,5 92 kW (108 125 hp) 9,1:1 2293 92 Kw <u>1974-84</u></p> <p>Taurus Capri Escort Sierra Granada</p>	<p>17-2510650 STD 17-2510653 0.50</p>	<p>A = 44,700 B = 79,200</p>	<p>RE23250000 -STD RE23250050 -0.50 RE23250100 -1.00</p> <p>2,000 (500) Cr IF 3,000 (501) P 4,000 (700) Cr P S</p>	<p>ø24,0 x 70,0</p>			
<p>ø90,00</p> <p>4 Cyl. Diesel 2112 cc 46/43/48/55/78 Kw (59/63/56/75/95/106 Ps) XD4.90 XDP4.90 XDP6.90WTA <u>1969....</u></p> <p>J 72.1 D 504 2.1 D J 9 2.1 D J 7 2.1 D Granada 2.1 D Blitz 2.1 D</p>	<p>18-7550940 STD Gömleklı Kodu 19-7550940 STD 18-7550943 0.50 Gömleklı Kodu 19-7550943 0.50 18-7550948 1.00 Gömleklı Kodu 19-7550948 1.00</p>	<p>A = 57,200 B = 96,350 C = 2,000</p>	<p>RE47170000 -STD RE47170050 -STD RE47170100 -STD</p> <p>2,000 (500) Cr 2,000 (501) P 2,000 (508) P 4,500 (604) P</p>	<p>ø28,0 x 77,0</p>	<p>G96001733S_1</p> <p>A= 96,000 B= 90,000 D= 106,300 F= 0,000 H= 129,050 L= 173,350</p> 		

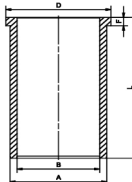





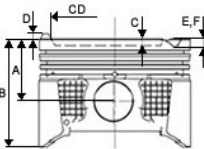
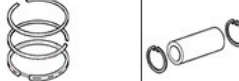

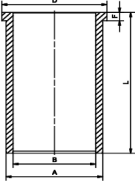
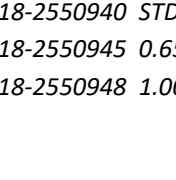
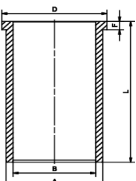
							
Motor /Engine	Ref. No. Kit 1	Ölçüler /Dimensions	Segman /Rings	Pim	Gömlek /Liner	Kit 2	Info
<p>ø90,80</p> <p>4 Cyl. Benzin, 1998 cm³ 57 64 kW (78 87 hp), 8,6:1 LC</p> <p><u>1970-82</u></p> <p><i>Taurus Capri Escort Sierra Granada</i></p>	<p>18-2510400 STD 18-2510403 0.50</p>	<p>A = 40,250 B = 68,250</p>	<p>RE23270000 -STD</p> <p>1,600 (500) Cr P 2,000 (501) P 4,000 (700) Cr P S</p>	<p>ø24,0 x 70,0</p>			
<p>ø90,80</p> <p>4 Cyl. Benzin, 1994 cm³ 73,5 kW (100 hp), 9,2:1 HC</p> <p><u>1986-1993</u></p> <p><i>Taurus Capri Escort Sierra Granada</i></p>	<p>18-2510450 STD 18-2510453 0.50 18-2510458 1.00</p>	<p>A = 41,550 B = 69,550</p>	<p>RE23270000 -STD</p> <p>1,600 (500) Cr P 2,000 (501) P 4,000 (700) Cr P S</p>	<p>ø24,0 x 70,0</p>			



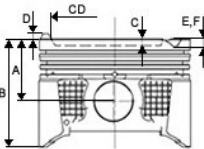





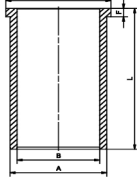
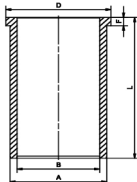



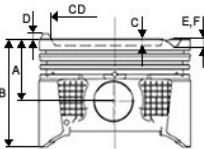



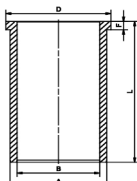

							
Motor /Engine	Ref. No. Kit 1	Ölçüler /Dimensions	Segman /Rings	Pim	Gömlek /Liner	Kit 2	Info
<p>ø93,00</p> <p>4 Cyl. Diesel 2500 cc 79 Ps XM34 WLOHC (1997 2004)</p> <p>Ranger Pick Up B2500 Pick Up</p>	<p>18-2581980 STD 18-2581983 0.50</p>	<p>A = 47,800 B = 87,400 C = 1,200</p> <p>Segman Taşıyıcı (Ring Carrier)</p> <p>Sac Plaka (Steel Support)</p>	<p>RE23530000 -STD RE23530050 -0.50</p> <p>2,500 (500) Cr P IF 2,000 (501) Cr P IF 3,000 (604) Cr P</p>	<p>ø32,0 x 70,0</p>			
<p>ø93,00</p> <p>4 Cyl. Diesel 2500 cc 110 Ps XM34TD XM34TD/WL T 1998 -</p> <p>Ranger Pick Up Thunder, Ranger Pick Up XLT B2500 TD Ranger</p>	<p>18-2582990 STD 18-2582993 0.50</p>	<p>A = 47,850 B = 87,350 C = 2,100</p> <p>Segman Taşıyıcı (Ring Carrier)</p> <p>Yag Galerisi (Oil Gallery)</p> <p>Sac Plaka (Steel Support)</p> <p>Yag Püskürt. Oyugu (Oil Cut-Out)</p>	<p>RE23530000 -STD RE23530050 -0.50</p> <p>2,500 (500) Cr P IF 2,000 (501) Cr P IF 3,000 (604) Cr P</p>	<p>ø32,0 x 70,0</p>	<p>G93001620K_1</p> <p>A= 96,000 B= 92,300 D= 97,500 F= 5,000 H= 0,000 L= 162,000</p>		



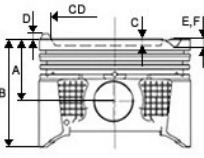



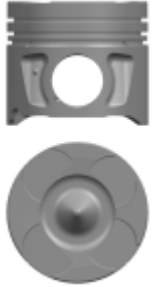

							
Motor /Engine	Ref. No. Kit 1	Ölçüler /Dimensions	Segman /Rings	Pim	Gömlek /Liner	Kit 2	Info
<p>ø93,00</p> <p>4 Cyl. Diesel 2499cc 143 PS FORD&MAZDA ORTAK (COMMON) 6M34 WL C 2006 -..... Ranger Pickup TDCI</p>	<p>18-2584020 STD 18-2584023 0.50</p>	<p>A = 51,750 B = 81,300 C = 15,100 CD= 48,500</p> <p>Segman Taşıyıcı (Ring Carrier)</p> <p>Yag Galerisi (Oil Gallery)</p>	<p>RJ30004A00 -STD RJ30004C00 -0.50</p> <p>2,000 () GN SM 1,500 () RN 2,000 () GN</p>	<p>ø34,0 x 70,0</p>	<p>G93001710K_1</p> <p>A= 96,000 B= 92,300 D= 97,500 F= 5,000 H= 0,000 L= 171,000</p> 		<p>STDconta +0,08 +0,15</p> <p>1 kertik conta +0,13 +0,25</p> <p>2 kertik conta +0,20 +0,31</p>
<p>ø93,67</p> <p>4 Cyl. Diesel 2496 cc 100 Ps 2.5 Di TC 2000 -..... Transit V5 Minibüs Transit 2,5</p>	<p>18-2550880 STD 18-2550880-20 STD (-0.20 mm) 18-2550885 0.65 18-2550885-20 0.65 (-0.20 mm) 18-2550888 1.00</p>	<p>A = 59,420 B = 93,950 C = 18,400 CD= 44,000</p> <p>Segman Taşıyıcı (Ring Carrier)</p>	<p>RE23510000 -STD RE23510065 -0.65 RE23510100 -1.00</p> <p>2,500 (503) Cr P 2,000 (508) P 4,000 (604) Cr P</p>	<p>ø29,0 x 79,3</p>	<p>G93651740K_1</p> <p>A= 97,400 B= 92,970 D= 98,500 F= 5,500 H= 0,000 L= 174,000</p> 		



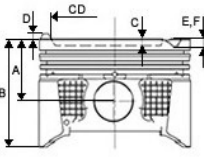



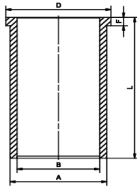

Motor /Engine	Ref. No. Kit 1	Ölçüler /Dimensions	Segman /Rings	Pim	Gömlek /Liner	Kit 2	Info
 <p>ø93,67</p> <p>4 Cyl. Diesel 2496 cc 51/60 Kw (68 80Ps) 89 MY D1 M4 T/6110 BA <u>1990 -</u></p> <p><i>Triton Motorlar Kamyonet Transit V6 Kamyonet Van V5T2, Minibüs V4.T1 Otosan Transit T3 Transit (80,100,120,130,160,190)</i></p>	 <p>18-2550930 STD 18-2550935 0.65 18-2550938 1.00</p>	 <p>A = 59,500 B = 94,000 C = 18,000 CD= 40,000</p> <p>Segman Taşıyıcı (Ring Carrier)</p> <p>Sac Plaka (Steel Support)</p>	 <p>RE23210000 -STD RE23210065 -0.65 RE23210100 -1.00</p> <p>2,500 (505) CrB Fe P S 2,000 (501) P IF 4,000 (604) Cr P</p>	<p>ø29,0 x 77,0</p>	 <p>G93651740K_1</p> <p>A= 97,400 B= 92,970 D= 98,500 F= 5,500 H= 0,000 L= 174,000</p> 		
<p>ø93,67</p> <p>4 Cyl. Diesel, 2496 cm³ 52 56 kW (71 76 hp) 4FA 4FB 4BC 4CC <u>1998-200</u></p> <p><i>Transit 2,5</i></p>	 <p>18-2550940 STD 18-2550945 0.65 18-2550948 1.00</p>	<p>A = 59,500 B = 89,500 C = 18,000 CD= 40,000</p> <p>Segman Taşıyıcı (Ring Carrier)</p> <p>Sac Plaka (Steel Support)</p>	<p>RE23210000 -STD RE23210065 -0.65 RE23210100 -1.00</p> <p>2,500 (505) CrB Fe P S 2,000 (501) P IF 4,000 (604) Cr P</p>	<p>ø29,0 x 77,0</p>	<p>G93651740K_1</p> <p>A= 97,400 B= 92,970 D= 98,500 F= 5,500 H= 0,000 L= 174,000</p> 		



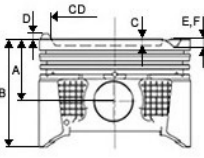



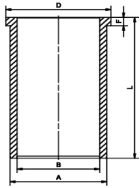

							
Motor /Engine	Ref. No. Kit 1	Ölçüler /Dimensions	Segman /Rings	Pim	Gömlek /Liner	Kit 2	Info
<p>ø93,67</p> <p>4 Cyl. Diesel 2496 cc 73,6 Kw (100 Ps) 944 F 6110 AAC2.5DI 4EA <u>1991 -</u> Otosan Üretimi Minibüs Van Transit 2.5 TD</p>	<p>18-2550950 STD 18-2550950-20 STD (-0.20 mm) 18-2550955 0.65 18-2550955-20 0.65 (-0.20 mm) 18-2550958 1.00 18-2550958-20 1.00 (-0.20 mm)</p>	<p>A = 59,420 B = 93,950 C = 18,400 CD= 44,000</p> <p>Segman Taşıyıcı (Ring Carrier)</p>	<p>RE23210000 -STD RE23210065 -0.65 RE23210100 -1.00</p> <p>2,500 (505) CrB Fe P S 2,000 (501) P IF 4,000 (604) Cr P</p>	<p>ø29,0 x 79,3</p>	<p>G93651740K_1</p> <p>A= 97,400 B= 92,970 D= 98,500 F= 5,500 H= 0,000 L= 174,000</p> 		
<p>ø93,67</p> <p>4 Cyl. Diesel 2496 cc 76 Ps 2.5 DI TC <u>1995 -</u> Transit 2,5</p>	<p>18-2550960 STD 18-2550960-20 STD (-0.20 mm) 18-2550965 0.65 18-2550965-20 0.65 (-0.20 mm) 18-2550968 1.00</p>	<p>A = 59,520 B = 94,000 C = 18,000 CD= 40,000</p> <p>Segman Taşıyıcı (Ring Carrier)</p>	<p>RE23510000 -STD RE23510065 -0.65 RE23510100 -1.00</p> <p>2,500 (503) Cr P 2,000 (508) P 4,000 (604) Cr P</p>	<p>ø29,0 x 77,0</p>	<p>G93651740K_1</p> <p>A= 97,400 B= 92,970 D= 98,500 F= 5,500 H= 0,000 L= 174,000</p> 		<p>+0,25 +0,40</p>

							
Motor /Engine	Ref. No. Kit 1	Ölçüler /Dimensions	Segman /Rings	Pim	Gömlek /Liner	Kit 2	Info
<p>ø93,67</p> <p>4 Cyl. Diesel 2496 cc 76 Ps 4EB 4EC D25T <u>1995 -....</u> Transit 2,5</p>	<p>18-2550970 STD 18-2550975 0.65</p>	<p>A = 59,410 B = 93,950 C = 18,400 CD= 44,000</p> <p>Segman Taşıyıcı (Ring Carrier)</p>	<p>RE23510000 -STD RE23510065 -0.65 RE23510100 -1.00</p> <p>2,500 (503) Cr P 2,000 (508) P 4,000 (604) Cr P</p>	<p>ø29,0 x 77,0</p>	<p>G93651740K_1</p> <p>A= 97,400 B= 92,970 D= 98,500 F= 5,500 H= 0,000 L= 174,000</p>		
<p>ø93,67</p> <p>4 Cyl. Diesel 2358 cc 43,5/45,5 Kw 2401 E YORK 2402 E YORK <u>1992 -....</u> A0505 A0609 Transit FT7/80/902 /100/115 Transit FT120/125 /130/150/160 A0409 A0509 A0609 A0709</p>	<p>18-2552140 STD 18-2552145 0.65 18-2552148 1.00</p>	<p>A = 61,670 B = 108,000 C = 0,800</p>	<p>RE23490000 -STD RE23490065 -0.65 RE23490100 -1.00</p> <p>2,385 (503) Cr P 2,385 (508) P 4,747 (604) Cr P</p>	<p>ø29,0 x 74,5</p>	<p>G93651740K_1</p> <p>A= 97,400 B= 92,970 D= 98,500 F= 5,500 H= 0,000 L= 174,000</p>		<p>0,114 +0,213</p>

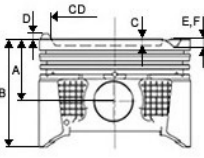







							
Motor /Engine	Ref. No. Kit 1	Ölçüler /Dimensions	Segman /Rings	Pim	Gömlek /Liner	Kit 2	Info
<p>ø83,00</p> <p>6 Cyl.Diesel 3000 cc 630 Motor VM <u>2012 -.</u></p> <p>A630 L630 630T Maserati Quattro Porte</p>	<p>17-9792080 STD 17-9792083 0.50 17-9792088 1.00</p>	<p>A = 46,630 B = 72,630 C = 15,800 E = -1,171 F = -1,220 CD= 43,500</p> <p>Segman Taşıyıcı (Ring Carrier)</p> <p>Yag Galerisi (Oil Gallery)</p>	<p>RE40130000 -STD RE40130050 -0.50 RE40130100 -1.00</p> <p>2,000 (505) Cr P IF 2,000 (501) P IFU 2,000 (604) Cr P</p>	<p>ø30,0 x 67,0</p>			
							



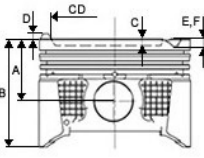



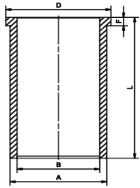

							
Motor /Engine	Ref. No. Kit 1	Ölçüler /Dimensions	Segman /Rings	Pim	Gömlek /Liner	Kit 2	Info
<p>ø66,00</p> <p>4 Cyl. Benzin 999 cc 40kW 54ps G4HC <u>1997 - 2002</u></p> <p>Atos 1.0 12V Santra 1.0 12V</p>	<p>18-4010100 STD 18-4010103 0.50</p>	<p>A = 25,100 B = 50,000 C = 4,500 E = -3,400 CD= 60,300</p>	<p>RJ40527A00 -STD RJ40527C00 -0.50</p> <p>1,200 () 1,200 () 2,500 ()</p>	<p>ø17,0 x 46,5</p>			
<p>ø71,00</p> <p>4 Cyl. Benzin 1248 cc 57 KW 78 PS 1 G4LA <u>2008 -</u></p> <p>i10 1,2 16v i20 1,2 16v</p>	<p>18-4011010 STD 18-4011013 0.50</p> 	<p>A = 24,700 B = 43,900 C = 3,000 E = -2,820 F = -2,670</p>	<p>RJ40023A00 -STD RJ40023C00 -0.50</p> <p>1,000 () 1,200 () 2,000 ()</p>	<p>ø18,0 x 48,0</p>	<p>G71001150KD_1</p> <p>A= 74,000 B= 70,300 D= 0,000 F= 0,000 H= 0,000 L= 115,000</p> 		

							
Motor /Engine	Ref. No. Kit 1	Ölçüler /Dimensions	Segman /Rings	Pim	Gömlek /Liner	Kit 2	Info
<p>ø71,50</p> <p>4 Cyl. Benzin 1300 cc G4EH <u>1995 - 1998</u> Accent 1,3</p>	<p>18-4011050 STD 18-4011053 0.50</p>	<p>A = 31,300 B = 54,400 C = 1,100 E = -2,000 CD= 59,000</p>	<p>RJ40770A00 -STD RJ40770C00 -0.50 RJ40770D00 -0.75</p> <p>1,500 () FV 1,500 () 3,000 ()</p>	<p>ø18,0 x 47,5</p>			
<p>ø71,50</p> <p>4 Cyl. Benzin 1300 cc 75 Ps G4K G4EA <u>2000 -....</u> Accent 1,3</p>	<p>18-4011060 STD 18-4011063 0.50</p>	<p>A = 30,800 B = 53,900 C = 0,700 E = -2,200 CD= 57,900</p>	<p>RJ40770A00 -STD RJ40770C00 -0.50 RJ40770D00 -0.75</p> <p>1,500 () FV 1,500 () 3,000 ()</p>	<p>ø18,0 x 47,5</p>	<p>G71501320K_1</p> <p>A= 74,500 B= 70,800 D= 76,000 F= 5,000 H= 0,000 L= 132,000</p> 		

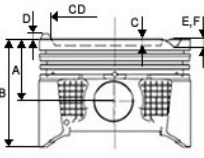







							
Motor /Engine	Ref. No. Kit 1	Ölçüler /Dimensions	Segman /Rings	Pim	Gömlek /Liner	Kit 2	Info
<p>ø72,00</p> <p>4 Cyl. Benzin 74/76 Kw (101/103 Ps) G4LC <u>2014 -</u></p> <p>Accent Accent Blue i20 i20 Coupe i30 i30 CW</p>	<p>18-4011080 STD 18-4011083 0.50</p>	<p>A = 24,700 B = 42,700 C = 3,600 E = -2,500</p>	<p>RJ40008A00 -STD RJ40008C00 -0.50</p> <p>1,000 () 1,200 () 2,000 ()</p>	<p>ø18,0 x 48,0</p>			
<p>ø75,00</p> <p>4 Cyl. Diesel 1396 cc 90 D4FC <u>2011 -</u></p> <p>Accent 1.4 CRDi i20 1.4 CRDi iX20 1.4 CRDi</p>	<p>18-4092510 STD 18-4092513 0.50</p>	<p>A = 44,700 B = 68,500 C = 11,800 E = -0,500 CD= 43,400</p> <p>Segman Taşıyıcı (Ring Carrier)</p> <p>Sert Anotlama (Hard Anodising)</p> <p>Yag Galerisi (Oil Gallery)</p>	<p>RJ40302A00 -STD RJ40302C00 -0.50</p> <p>1,750 () SM 1,750 () 3,000 ()</p>	<p>ø28,0 x 62,0</p>			



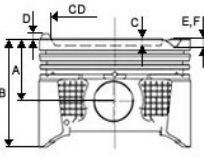





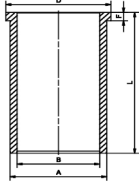
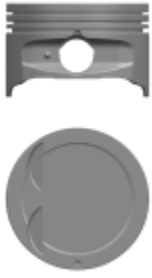
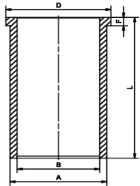



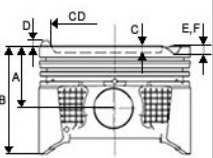





							
Motor /Engine	Ref. No. Kit 1	Ölçüler /Dimensions	Segman /Rings	Pim	Gömlek /Liner	Kit 2	Info
<p>ø75,00</p> <p>4 Cyl. Diesel 1493cc 81 Kw (110 Ps) 17.8:1 D4FA C.Rail <u>2005 -</u> Accent Era 1.5 CRDI-VGT16v</p>	<p>18-4092520 STD 18-4092523 0.50</p>	<p>A = 41,950 B = 65,700 C = 12,200 E = -0,500 CD= 43,400</p> <p>Segman Taşıyıcı (Ring Carrier)</p> <p>Yag Galerisi (Oil Gallery)</p> <p>Yag Püskürt. Oyugu (Oil Cut-Out)</p>	<p>RJ40302A00 -STD RJ40302C00 -0.50</p> <p>1,750 () SM 1,750 () 3,000 ()</p>	<p>ø28,0 x 62,0</p>			
<p>ø75,50</p> <p>4 Cyl. Benzin 1399 cc 97 PS 10:1 G4EE <u>2005 -</u> 1.4 DOCH AccentEra 1.4 16v</p>	<p>18-4011070 STD 18-4011073 0.50</p>	<p>A = 28,750 B = 47,900 D = 2,200 E = -2,950</p>	<p>RJ40112A00 -STD RJ40112C00 -0.50</p> <p>1,200 () SV 1,200 () 2,000 () GN</p>	<p>ø18,0 x 47,9</p>	<p>G75501320K_1</p> <p>A= 78,500 B= 74,800 D= 79,500 F= 5,000 H= 0,000 L= 132,000</p>		

							
Motor /Engine	Ref. No. Kit 1	Ölçüler /Dimensions	Segman /Rings	Pim	Gömlek /Liner	Kit 2	Info
<p>ø75,50</p> <p>4 Cyl. Benzin 1495 cc G4EK <u>1990 - 2000</u> Accent 1,5</p>	<p>18-4011100 STD 18-4011103 0.50</p>	<p>A = 31,370 B = 54,400 C = 0,700 E = -2,200 CD= 64,300</p>	<p>RJ40765A00 -STD RJ40765C00 -0.50</p> <p>1,500 () RN FV 1,500 () 3,000 ()</p>	<p>ø18,0 x 47,5</p>			
<p>ø75,50</p> <p>4 Cyl. Benzin 1500cc G4EC/G G4EB <u>2000 -</u> ACCENT 1,5 MILENYUM</p>	<p>18-4011110 STD 18-4011113 0.50</p>	<p>A = 31,070 B = 54,400 D = 0,950 E = -3,000</p>	<p>RJ40063A00 -STD RJ40063C00 -0.50</p> <p>1,200 () SV 1,500 () 3,000 ()</p>	<p>ø18,0 x 47,5</p>			

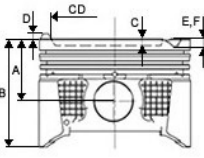







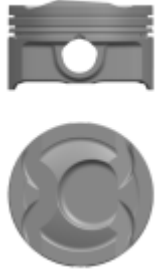

							
Motor /Engine	Ref. No. Kit 1	Ölçüler /Dimensions	Segman /Rings	Pim	Gömlek /Liner	Kit 2	Info
<p>ø75,50</p> <p>4 Cyl. Benzin 1468cc 56 Kw (76 Ps) 8,5:1 G15B <u>1990 - 2004</u> EXCEL 1.5</p>	<p>18-4011120 STD 18-4011123 0.50</p> 	<p>A = 29,400 B = 58,800 C = 3,700</p>	<p>RJ20520A00 -STD RJ20520C00 -STD</p> <p>1,500 () FV 1,500 () 4,000 ()</p>	<p>ø18,0 x 60,0</p>	<p>G75501320K_1</p> <p>A= 78,500 B= 74,800 D= 79,500 F= 5,000 H= 0,000 L= 132,000</p> 		
<p>ø76,50</p> <p>4 Cyl. Benzin 1588cc 16 Valve G4ED <u>2004 -</u> ACCENT 1.6i 16v</p>	<p>18-4011130 STD 18-4011133 0.50</p> 	<p>A = 28,140 B = 50,140 C = 0,400 E = -3,000 CD= 60,400</p>	<p>RJ40082A00 -STD RJ40082C00 -0.50</p> <p>1,200 () RN FV 1,200 () 2,000 ()</p>	<p>ø18,0 x 47,5</p>	<p>G76501320K_1</p> <p>A= 79,500 B= 75,800 D= 81,000 F= 5,000 H= 0,000 L= 132,000</p> 		

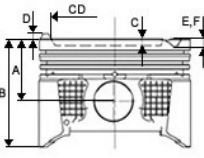





							
Motor /Engine	Ref. No. Kit 1	Ölçüler /Dimensions	Segman /Rings	Pim	Gömlek /Liner	Kit 2	Info
<p>ø77,00</p> <p>4 Cyl. Benzin 1591 cc 130kW 170 PS G4FJ <u>2015 - 2019</u></p> <p><i>i 30 KONA TUSCON VELOSTER CEED OPTIMA PROCEED SELTOS SOLU i/III SPORTAGE XCEED</i></p>	<p>18-4010020 STD 18-4010023 0.50</p>	<p>A = 27,900 B = 45,000 C = 3,000 E = -2,300 F = -3,300 CD= 69,200</p> <p>Segman Taşıyıcı (Ring Carrier)</p>	<p>RJ39931A00 -STD RJ39931C00 -0.50</p> <p>1,200 () 1,500 () 2,000 ()</p>	<p>ø20,0 x 52,0</p>			
<p>ø77,00</p> <p>4 Cyl. Benzin 1591 cc 137kW 186 PS 2017 Sonrası G4FJ <u>2017 -</u></p> <p><i>i 30 i30 COUPE KONA TUSCON VELOSTER</i></p>	<p>18-4010030 STD 18-4010033 0.50</p>	<p>A = 28,000 B = 45,000 C = 3,200 E = -2,200 F = -2,900 CD= 39,100</p> <p>Segman Taşıyıcı (Ring Carrier)</p>	<p>RJ39931A00 -STD RJ39931C00 -0.50</p> <p>1,200 () 1,500 () 2,000 ()</p>	<p>ø20,0 x 52,0</p>			





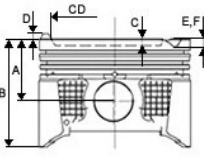
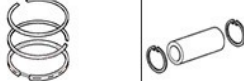

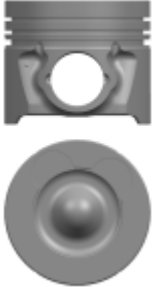
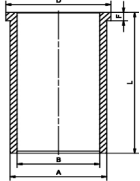
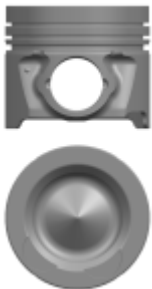

							
Motor /Engine	Ref. No. Kit 1	Ölçüler /Dimensions	Segman /Rings	Pim	Gömlek /Liner	Kit 2	Info
<p>ø77,00</p> <p>4 Cyl. Benzin 1591 cc 95.6 KW 140 PS G4FD <u>2010 -....</u></p> <p>Accent 1,6 16v Elantra 1,6 16v I20 1,6 16v I30 1,6 16v IX 35 1,6 16v</p>	<p>18-4011190 STD 18-4011190-30 STD 18-4011193 0.50 18-4011193-30 0.50</p>	<p>A = 26,900 B = 45,000 D = 2,900 E = -2,940 F = -2,700</p> <p>Sert Anotlama (Hard Anodising)</p>	<p>RJ40166A00 -STD RJ40166C00 -0.50</p> <p>1,200 () SV 1,200 () 2,000 ()</p>	<p>ø18,0 x 52,3</p>			<p>0,035 0,105 mm</p> <p>0,105 0,175 mm</p> <p>0,175 0,245 mm</p>
<p>ø77,00</p> <p>4 Cyl. Benzin 1396 cc 66/73/74 KW 87/90/100/101 PS G4FA <u>2009 -....</u></p> <p>Accent 1,4 16v I20 1,4 16v I30 1,4 16v</p>	<p>18-4011200 STD 18-4011203 0.50</p>	<p>A = 26,900 B = 43,900 C = 1,400 E = -3,100</p>	<p>RJ40166A00 -STD RJ40166C00 -0.50</p> <p>1,200 () SV 1,200 () 2,000 ()</p>	<p>ø18,0 x 52,3</p>			



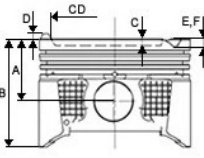





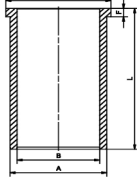

							
Motor /Engine	Ref. No. Kit 1	Ölçüler /Dimensions	Segman /Rings	Pim	Gömlek /Liner	Kit 2	Info
<p>ø77,00</p> <p>4 Cyl. Benzin 1591 cc 88 KW 120 PS G4FG <u>2011 -....</u></p> <p><i>Elantra 1,6 16v I30 1,6 16v</i></p>	<p>18-4011210 STD 18-4011213 0.50 18-4011215 0.65</p>	<p>A = 26,900 B = 43,900 C = 0,850 E = -2,000 F = -3,000</p> <p>Sert Anotlama (Hard Anodising)</p>	<p>RJ40166A00 -STD RJ40166C00 -0.50</p> <p>1,200 () SV 1,200 () 2,000 ()</p>	<p>ø18,0 x 52,3</p>			
<p>ø77,00</p> <p>4 Cyl. Benzin 1591 cc 96 KW 130 PS G4FC</p> <p><i>i20 1,6 16v I30 1,6 16v</i></p>	<p>18-4011220 STD 18-4011223 0.50</p>	<p>A = 26,900 B = 43,900 C = 0,950 E = -2,800</p>	<p>RJ40166A00 -STD RJ40166C00 -0.50</p> <p>1,200 () SV 1,200 () 2,000 ()</p>	<p>ø18,0 x 52,3</p>			

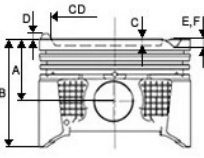







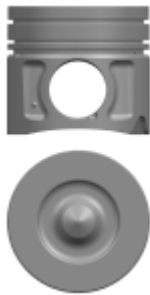
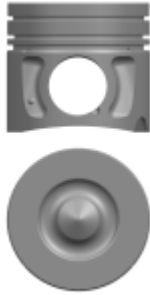



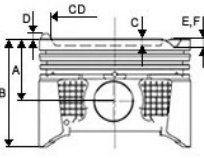



							
Motor /Engine	Ref. No. Kit 1	Ölçüler /Dimensions	Segman /Rings	Pim	Gömlek /Liner	Kit 2	Info
<p>ø77,20</p> <p>4 Cyl. Diesel 1582 cc 84kW 115PS 17:3 D4FB 1.6 CRDi <u>2007 -</u> I30 Cerato</p>	<p>18-4092530 STD 18-4092533 0.50</p> 	<p>A = 41,950 B = 65,700 C = 12,700 E = -0,500 CD= 44,000</p> <p>1,750 () 1,750 () 3,000 ()</p> <p>Segman Taşıyıcı (Ring Carrier)</p> <p>Yag Galerisi (Oil Gallery)</p>	<p>RJ40274A00 -STD RJ40274C00 -0.50</p> <p>1,750 () 1,750 () 3,000 ()</p>	<p>ø28,0 x 62,0</p>	<p>G77201400K_1</p> <p>A= 80,200 B= 76,500 D= 81,700 F= 5,000 H= 0,000 L= 140,000</p> 		
<p>ø77,20</p> <p>4 Cyl. Diesel 1582 cc 100kW 136PS D4FB 1.6 CRDi <u>2015 -</u> 1.6 CRDI I30 2015....</p>	<p>18-4092580 STD 18-4092583 0.50</p> 	<p>A = 42,000 B = 65,700 C = 12,600 E = -0,600 CD= 47,100</p> <p>1,750 () 1,750 () 3,000 ()</p> <p>Segman Taşıyıcı (Ring Carrier)</p> <p>Sert Anotlama (Hard Anodising)</p> <p>Yag Galerisi (Oil Gallery)</p>	<p>RJ40274A00 -STD RJ40274C00 -0.50</p> <p>1,750 () 1,750 () 3,000 ()</p>	<p>ø28,0 x 64,0</p>			

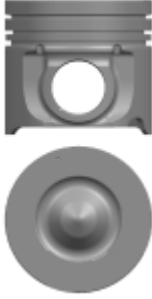
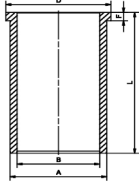
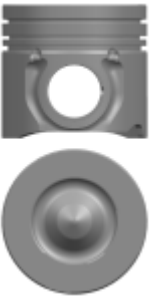



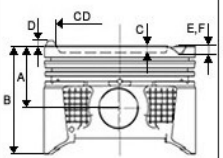
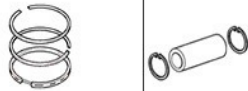

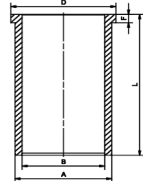
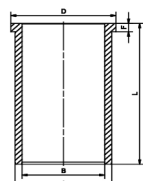

							
Motor /Engine	Ref. No. Kit 1	Ölçüler /Dimensions	Segman /Rings	Pim	Gömlek /Liner	Kit 2	Info
<p>ø83,00</p> <p>3/4 Cyl. Diesel 1493/1991 cc (-0.20 mm) 60/82/100 Kw (82/112 Ps) 17.7:11 D3EA D4EA <u>2001 -</u></p> <p>Accent 1.5 CRDI Getz 1.5 CRDI Tuscon 2.0 CRDI Santa FE 2.0 CRDI Sportage 2. CRDI Carens 2.0 CRDI</p>	<p>17-4094540 STD 17-4094540-20 STD (-0.20 mm) 17-4094543 0.50 17-4094543-20 0.50 (-0.20 mm)</p>	<p>A = 46,300 B = 72,300 C = 13,900 CD= 46,950</p> <p>Segman Taşıyıcı (Ring Carrier)</p> <p>Yag Püskürt. Oyugu (Oil Cut-Out)</p> <p>Burc (Bushing)</p>	<p>RJ39597A00 -STD RJ39597C00 -0.50</p> <p>2,000 () 2,000 () 3,000 ()</p>	<p>ø28,0 x 65,5</p>	<p>G83001550K_1</p> <p>A= 83,000 B= 79,300 D= 85,000 F= 5,000 H= 0,000 L= 155,000</p> 		
<p>ø83,00</p> <p>4 Cyl. Diesel 1991 cc 92kW 125PS 17.7:1 D4EA <u>2001 -</u></p> <p>Santa Fe 2.0 CRDI 16V Tuscon 2.0 CRDI 16V</p>	<p>18-4094550 STD 18-4094553 0.50</p>	<p>A = 46,300 B = 72,300 C = 13,700 CD= 48,500</p>	<p>RJ40089A00 -STD RJ40089C00 -0.50</p> <p>1,915 () SM 2,000 () 3,000 ()</p>	<p>ø28,0 x 65,5</p>			



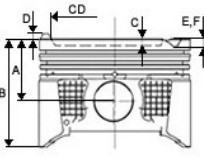





							
Motor /Engine	Ref. No. Kit 1	Ölçüler /Dimensions	Segman /Rings	Pim	Gömlek /Liner	Kit 2	Info
<p>ø84,00</p> <p>4 Cyl. Diesel 1995 cc /100 Kw (1362 Ps) 16,51 D4HA 2009 -</p> <p>IX35 Santa FE 2.0 Sorento Sportage</p>	<p>18-4092560 STD 18-4092563 0.50</p>	<p>A = 48,900 B = 75,900 C = 15,700 CD= 45,400</p> <p>Segman Taşıyıcı (Ring Carrier)</p> <p>Yag Galerisi (Oil Gallery)</p> <p>Yag Püskürt. Oyugu (Oil Cut-Out)</p>	<p>RJ40026A00 -STD RJ40026C00 -0.50</p> <p>2,500 () 2,000 () 3,000 ()</p>	<p>ø36,0 x 80,8</p>			
<p>ø85,40</p> <p>4 Cyl. Diesel 2199 cc 147kW 200PS D4HB 2009 -</p> <p>Sorento II-III</p>	<p>18-4092570 STD 18-4092573 0.50</p>	<p>A = 49,900 B = 76,900 C = 16,100 CD= 47,400</p> <p>Segman Taşıyıcı (Ring Carrier)</p> <p>Yag Galerisi (Oil Gallery)</p> <p>Yag Püskürt. Oyugu (Oil Cut-Out)</p>		<p>ø36,0 x 80,8</p>			



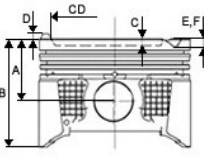
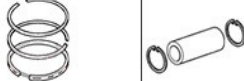





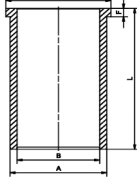



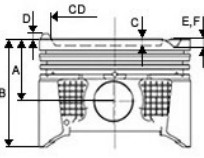





							
Motor /Engine	Ref. No. Kit 1	Ölçüler /Dimensions	Segman /Rings	Pim	Gömlek /Liner	Kit 2	Info
<p>ø91,00</p> <p>4 Cyl. Diesel 2497 cc 74/95 Kw (110/129 Ps) D4CB CRDI 2002 -.... Starex 2.5 CRDI Sorento</p>	<p>18-4050050 STD 18-4050053 0.50</p> 	<p>A = 54,250 B = 83,750 C = 15,000 E = -0,300 CD= 52,000</p> <p>Segman Taşıyıcı (Ring Carrier)</p> <p>Yag Galerisi (Oil Gallery)</p> <p>Yag Püskürt. Oyugu (Oil Cut-Out)</p>	<p>RJ39613A00 -STD RJ39613C00 -0.50</p> <p>2,500 () 2,000 () 3,000 ()</p>	<p>ø33,0 x 75,0</p>	<p>G91001700KD_1</p> <p>A= 94,200 B= 90,300 D= 0,000 F= 0,000 H= 0,000 L= 170,000</p> 		<p>+ 0,06 + 0,24</p>
<p>ø91,00</p> <p>4 Cyl. Diesel 2497 cc 125 Kw (170 BG) D4BC-.... Stratex 2.5 CRDI</p>	<p>18-4094900 STD 18-4094903 0.50</p> 	<p>A = 54,250 B = 83,700 C = 15,000 E = -0,340 CD= 52,000</p> <p>Segman Taşıyıcı (Ring Carrier)</p> <p>Yag Galerisi (Oil Gallery)</p> <p>Yag Püskürt. Oyugu (Oil Cut-Out)</p> <p>Burc (Bushing)</p>	<p>RJ39613A00 -STD RJ39613C00 -0.50</p> <p>2,500 () 2,000 () 3,000 ()</p>	<p>ø33,0 x 74,0</p>			



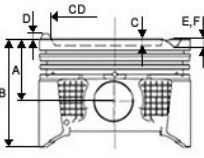





Motor /Engine	Ref. No. Kit 1	Ölçüler /Dimensions	Segman /Rings	Pim	Gömlek /Liner	Kit 2	Info
							
ø91,10 4 Cyl. Diesel 2467 cc 73 78 Kw (99 106) Ps D4BH 2000 -..... 2. & 4. Sil. Turbo Intercooler K2500 TCI Bongo Starex 2500 TCI	17-4050020 STD 17-4050020-20 STD (-0.20 mm) 17-4050023 0.50 17-4050023-20 0.50 (-0.20 mm) 17-4050028 1.00 17-4050028-20 1.00 (-0.20 mm)	A = 48,700 B = 88,700 C = 1,300 Segman Taşıyıcı (Ring Carrier) Yag Galerisi (Oil Gallery) Sac Plaka (Steel Support)	RJ40699A00 -STD RJ40699C00 -0.50 2,500 () RN FM 1,950 () RN 4,000 ()	ø29,0 x 75,0	G91101647K_1 A= 94,130 B= 90,400 D= 96,000 F= 5,000 H= 0,000 L= 164,750 		+ 0,50 + 0,60
ø91,10 4 Cyl. Diesel 2467 cc 73 78 Kw (99 106) Ps D4BH 2000 -..... 1. & 3. Sil. Turbo Intercooler K2500 TCI Bongo Starex 2500 TCI	17-4050030 STD 17-4050030-20 STD (-0.20 mm) 17-4050033 0.50 17-4050033-20 0.50 (-0.20 mm) 17-4050038 1.00 17-4050038-20 1.00 (-0.20 mm)	A = 48,700 B = 88,700 C = 1,300 Segman Taşıyıcı (Ring Carrier) Yag Galerisi (Oil Gallery) Sac Plaka (Steel Support)	RJ40699A00 -STD RJ40699C00 -0.50 2,500 () RN FM 1,950 () RN 4,000 ()	ø29,0 x 75,0	G91101647K_1 A= 94,130 B= 90,400 D= 96,000 F= 5,000 H= 0,000 L= 164,750 		+ 0,50 + 0,60



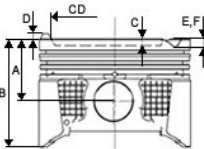



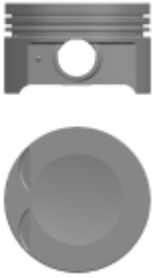

							
Motor /Engine	Ref. No. Kit 1	Ölçüler /Dimensions	Segman /Rings	Pim	Gömlek /Liner	Kit 2	Info
<p>ø91,10</p> <p>4 Cyl. Diesel 2477 cc D4BB 1994 -....</p> <p>H 100 2.5TD 1994> H1 2.5TDI 21:1 57-59Kw 78-80Ps 1997></p>	<p>18-4050040 STD 18-4050043 0.50</p>	<p>A = 48,700 B = 88,700 C = 3,200 D = 1,900 E = -2,500</p> <p>Sac Plaka (Steel Support)</p>	<p>RJ40525A00 -STD RJ40525C00 -0.50</p> <p>2,000 () GN SM 2,000 () CrI 3,000 () GN</p>	<p>ø29,0 x 75,0</p>			<p>1,45 mm conta + 0,562 + 0,620</p> <p>1,50 mm conta + 0,620 + 0,680</p> <p>1,55 mm conta + 0,680 + 0,774</p>
<p>ø91,10</p> <p>4 Cyl. Diesel 2600 cc H100 1996 -....</p> <p>H 100 Kamyonet Tek ve Çift Kabin</p>	<p>18-4050060 STD 18-4050060-20 STD (-0.20 mm) 18-4050063 0.50 18-4050063-20 0.50 (-0.20 mm)</p>	<p>A = 46,250 B = 76,150 C = 3,070 E = -2,000 F = -2,300</p> <p>Segman Taşıyıcı (Ring Carrier)</p>	<p>RJ40525A00 -STD RJ40525C00 -0.50</p> <p>2,000 () GN SM 2,000 () CrI 3,000 () GN</p>	<p>ø29,0 x 75,0</p>			<p>1,45 mm conta + 0,562 + 0,620</p> <p>1,50 mm conta + 0,620 + 0,680</p> <p>1,55 mm conta + 0,680 + 0,774</p>



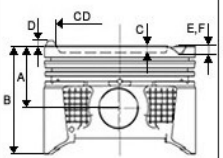



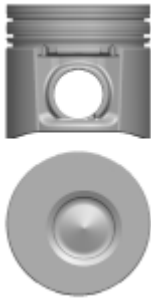

							
Motor /Engine	Ref. No. Kit 1	Ölçüler /Dimensions	Segman /Rings	Pim	Gömlek /Liner	Kit 2	Info
<p>ø91,10</p> <p>4 Cyl. Diesel 2500 cc D4BF 1998 -.... Starex 2.5 TC</p>	<p>18-4050070 STD 18-4050073 0.50</p> 	<p>A = 48,700 B = 88,700 C = 3,100 E = -2,300 F = -2,600</p> <p>Segman Taşıyıcı (Ring Carrier)</p> <p>Sac Plaka (Steel Support)</p>	<p>RJ40699A00 -STD RJ40699C00 -0.50</p> <p>2,500 () RN FM 1,950 () RN 4,000 ()</p>	<p>ø29,0 x 75,0</p>	<p>G91101645KD_1</p> <p>A= 94,100 B= 90,400 D= 0,000 F= 0,000 H= 0,000 L= 164,500</p> 		
<p>ø100,00</p> <p>4 Cyl. Diesel 3298 cc 69 Kw (94 Ps) 17 5:1 4D31 QA Canter 3300 (FE 444) H350</p>	<p>18-1550010 STD 18-1550013 0.50</p>	<p>A = 60,700 B = 110,700 C = 18,100 CD= 52,500</p> <p>Segman Taşıyıcı (Ring Carrier)</p> <p>Sac Plaka (Steel Support)</p>	<p>RJ20016A00 -STD RJ20016C00 -0.50</p> <p>3,000 () RN CrI FX 2,000 () 5,000 ()</p>	<p>ø18,0 x 52,3</p>			<p>+ 0,47 + 0,69</p>

							
Motor /Engine	Ref. No. Kit 1	Ölçüler /Dimensions	Segman /Rings	Pim	Gömlek /Liner	Kit 2	Info
<p>ø104,00</p> <p>4 Cyl. Diesel 3908cc 96 KW 130PS 4D34 1 ATA EUROII</p> <p>659 Canter Prestij TDI-HD 65-HD 72-HD 82</p>	<p>18-1550020 STD 18-1550023 0.50</p>	<p>A = 62,200 B = 112,200 C = 23,000 CD= 49,000</p> <p>Yag Galerisi (Oil Gallery)</p> <p>Sac Plaka (Steel Support)</p> <p>Yag Püskürt. Oyugu (Oil Cut-Out)</p>	<p>RJ20941A00 -STD RJ20941C00 -0.50</p> <p>3,000 () RN FM 2,000 () 4,000 ()</p>	<p>ø36,0 x 88,0</p>			<p>+ 0,60 + 0,70</p>

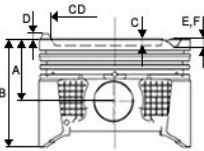





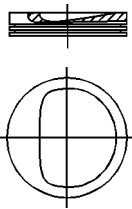

							
Motor /Engine	Ref. No. Kit 1	Ölçüler /Dimensions	Segman /Rings	Pim	Gömlek /Liner	Kit 2	Info
<p>ø73,40</p> <p>4 Cyl. Benzin 1229 cc 59 KW (80 PS) Z12XEP <u>2004 -....</u></p> <p><i>Corça C Agila Astra H Astra MK</i></p>	<p>18-3010150 STD 18-3010153 0.50</p>	<p>A = 24,000 B = 45,000 D = 0,530 E = -1,460 F = -1,490</p>	<p>RE43390000 -STD RE43390050 -0.50</p> <p>1,200 (500) NitBS 1,200 (508) P 2,000 (700) CrPS</p>	<p>ø18,0 x 50,9</p>			
<p>ø77,60</p> <p>4 Cyl. Benzin 1389 cc 66 Kw (90 Ps) Z1.4XE GLHB <u>1999 -....</u></p> <p><i>Astra 1.4 Corça 1.4 E16 SE16V C16 SE ENJ/KAT</i></p>	<p>18-3010300 STD 18-3010303 0.50</p>	<p>A = 31,300 B = 55,750 D = 2,450</p>	<p>RE43480000 -STD RE43480050 -0.50 RE43480100 -1.00</p> <p>1,200 (500) NitB S 1,500 (501) P 2,000 (700) Cr P S</p>	<p>ø18,0 x 55,0</p>			



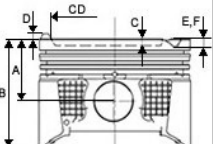



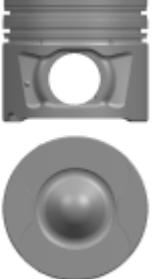
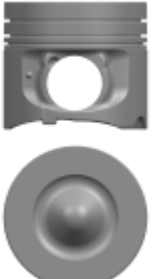

							
Motor /Engine	Ref. No. Kit 1	Ölçüler /Dimensions	Segman /Rings	Pim	Gömlek /Liner	Kit 2	Info
<p>ø79,00</p> <p>4Cyl. Benzin 1598 cc 74 Kw (101 Ps) Y16 XE Z16XE <u>2000 -....</u></p> <p>Vectra 1.6i 16v Astra 1.6i Meriva 1.6i 16v Zafira 1.6i 16v</p>	<p>18-3010390 STD <i>18-3010390-20 STD (-0.20 mm)</i></p> <p>18-3010393 0.50 <i>18-3010393-20 0.50 (-0.20 mm)</i></p> <p>18-3010398 1.00 <i>18-3010398-20 1.00 (-0.20 mm)</i></p> 	<p>A = 27,200 B = 50,200</p>	<p>RE43320000 -STD RE43320025 -0.25 RE43320050 -0.50 RE43320100 -1.00</p> <p>1,200 (500) Cr B S 1,500 (508) P 2,500 (700) Cr P S</p>	<p>ø18,0 x 55,0</p>			
<p>ø81,60</p> <p>4 Cyl. Benzin, 1796 cm³ 92 kW (125 hp) C18XE C18XEL <u>1993-2000</u></p> <p>Astra F Vectra B</p>	<p>18-3010790 STD 18-3010793 0.50</p> 	<p>A = 30,400 B = 50,400 C = 1,840 E = -1,790 CD= 50,800</p>	<p>RE43140000 -STD RE43140050 -0.50 RE43140100 -1.00</p> <p>1,500 (500) Cr B S IF 1,500 (508) P 3,000 (700) Cr P S</p>	<p>ø21,0 x 61,5</p>			

Motor /Engine	Ref. No. Kit 1	Ölçüler /Dimensions	Segman /Rings	Pim	Gömlek /Liner	Kit 2	Info
							
ø86,00 4 Cyl. Diesel 2369/1951 cc 37/40/44KW 54/60/65 PS C 240 C 190 <u>1998 -</u> HUAHE-C 240 C 190	18-3050360 STD	A = 51,600 B = 85,000 C = 2,000 E = -0,500 Segman Taşıyıcı (Ring Carrier) Sac Plaka (Steel Support)	RJ17390A00 -STD RJ17390C00 -0.50 2,500 () 2,000 () 5,000 ()	ø27,0 x 68,0			
							
ø94,40 4 Cyl. Diesel 2798 cc 76 Kw (103 Ps) 18,5:1 Sofim Turbo,Intercooler Euro 2 SOFIM TurboS9W700 702 <u>1996 -....</u> Movano 2.8 TD Ducato 2.8 TD 49.10 49.12 M14 Minibüs Turbo Daily35.12 Motor No: 2572280 --> Boxer 2.8 TD Master 2.8 TD/ Jumper 2.8 TD	18-3051670 STD 18-3051670-20 STD (-0.20 mm) 18-3051672 0.40 18-3051672-20 0.40 (-0.20 mm) 18-3051674 0.60 18-3051674-20 0.60 (-0.20 mm)	A = 58,750 B = 87,600 C = 19,400 CD= 39,500 Segman Taşıyıcı (Ring Carrier) Yag Galerisi (Oil Gallery) Yag Püskürt. Oyugu (Oil Cut-Out)	RE22780000 -STD RE22780040 -0.40 RE22780060 -0.60 2,500 (504) Cr P 2,000 (501) P 2,500 (604) Cr P	ø32,0 x 72,0			1,20 mm conta +0,40 +0,50 1,30 mm conta +0,51 +0,60 1,40 mm conta + 0,61 +0,70
							

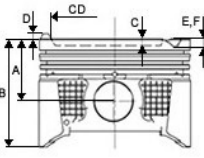







							
Motor /Engine	Ref. No. Kit 1	Ölçüler /Dimensions	Segman /Rings	Pim	Gömlek /Liner	Kit 2	Info
<p>ø112,02</p> <p>4 Cyl. Diesel 4334 cc 73,6/88,3 Kw (100 120 Ps) 4HF1 <u>1987 -....</u></p> <p>MD23 Midibüs MD25 Midibüs MD27 Midibüs NKR 66 Kamyonet NPR 66Kamyon Sampiyon</p>	<p>18-3050010 STD</p>	<p>A = 60,750 B = 94,500 C = 22,000 CD= 49,600</p> <p>Segman Taşıyıcı (Ring Carrier)</p> <p>Sac Plaka (Steel Support)</p>	<p>RJ17481A00 -STD RJ17481C00 -0.50</p> <p>3,000 () SM 2,500 () 4,000 () GN</p>	<p>ø36,0 x 79,0</p>			



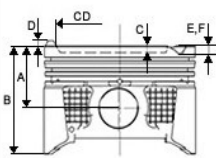







Motor /Engine	Ref. No. Kit 1	Ölçüler /Dimensions	Segman /Rings	Pim	Gömlek /Liner	Kit 2	Info
							
ø81,00 4/6/8 Cyl. Diesel 2720cc 150/200 KW(204/272 PS) 2.7 Lion TVM 276DT 368DT 2008 -.... DISCOVERY 2.7 TDI RANGE ROVER 2.7TDV6 (2008 -) RANGE ROVER SPORT (L320) 3,6 D 4x4 (04,2006 - 03,2013)	17-6592100 STD 17-6592103 0.50	A = 47,000 B = 71,000 C = 14,050 E = -0,500 CD= 44,000 Segman Taşıyıcı (Ring Carrier) Yag Galerisi (Oil Gallery)	RE47570000 -STD RE47570050 -0.50 2,000 (500) Cr PIF 2,000 (501) P IFU 2,000 (604) Nit S	ø29,0 x 62,0			
							
ø83,00 4 Cyl. Diesel 1997/1998/1999 cc 110/120/132/147 177 KW 150/163/179/180 200/204 PS 204DTA/D AJ20D4 AJ200D 2.0 INGENIUM TURBO DIESEL 2.0D 2.0 D/TD4/150/165/180 4x4 2.0 D AWD 2014 - XF/II/SPORTBRAKE (260) XE (760) F PACE (761) E PACE (X540) XJ DISCOVERY SPORT (L550) RANGE ROVER EVOQUE (L538/L551) DISCOVERY V(L462)	18-6592150 STD 18-6592153 0.50	A = 47,000 B = 73,600 C = 16,100 CD= 48,000 Segman Taşıyıcı (Ring Carrier) Yag Galerisi (Oil Gallery)	RE43510000 -STD RE43510040 -0.40 RE43510050 -0.50 1,500 (500) Cr P 1,500 (508) P 2,000 (604) Nit S	ø32,0 x 65,0			

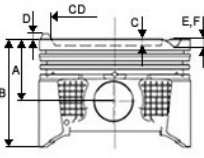







							
Motor /Engine	Ref. No. Kit 1	Ölçüler /Dimensions	Segman /Rings	Pim	Gömlek /Liner	Kit 2	Info
<p>ø85,00</p> <p>4/6 Cyl. Diesel 2179 cc 110 KW 211 PS DW12BTED4 <u>2011 - 2013</u> FREELANDER 2 2.2 TD4</p>	<p>17-6592300 STD 17-6592303 0.50</p>	<p>A = 48,705 B = 74,705 C = 13,475 E = -0,385 CD= 52,400</p> <p>Segman Taşıyıcı (Ring Carrier)</p> <p>Yag Galerisi (Oil Gallery)</p> <p>Yag Püskürt. Oyugu (Oil Cut-Out)</p>	<p>RE35000000 -STD RE35000050 -0.50</p> <p>2,500 (505) Cr P 2,000 (501) P IFU 2,000 (604) Nit S</p>	<p>ø30,0 x 68,0</p>			



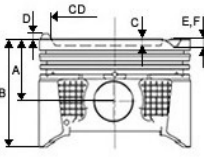





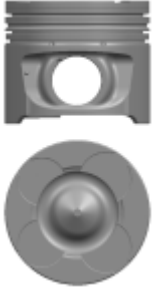



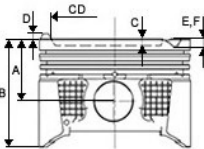





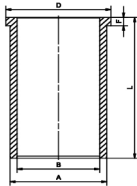

Motor /Engine	Ref. No. Kit 1	Ölçüler /Dimensions	Segman /Rings	Pim	Gömlek /Liner	Kit 2	Info
       							
ø79,50 4 Cyl. Diesel 1598 cc 70/74/77 84/85/88 KW 95/100/101 105/114/115 116/120 PS 16:5 1.6 16V Multi.jet (EURO 5) EJJ EJK 198 A2/A3.000 940/955 A3/C1/C5/A4.000 552 60 384/552 63 113 <u>2010 -</u> Bravo 1.6 16v Doblo II 1.6 16V Linea 1.616V FIAT Alfa Romeo Jeep Chrysler Lancia	18-2050040 STD 18-2050042 0.40	A = 43,950 B = 68,950 C = 13,800 E = -0,460 F = -0,600 CD= 41,700 Segman Taşıyıcı (Ring Carrier)	RE22880000 -STD RE22880040 -0.40 RE22880060 -0.60 1,500 (500) CrP 1,500 (508) P 2,000 (604) NitS	ø26,0 x 62,8			Deliksiz conta (0,82 mm) +0,02 +0,10 Tek delik conta (0,92 mm) +0,10 +0,20 İki delik conta +0,20 +0,30
ø91,48 6/4 Cyl. Benzin 5000/3335cc 52/73 KW 64/71/100PS 17,4:1 6.305 4.203 Perkins-Jeep Viasa	17-6650120 STD	A = 57,200 B = 107,900	RE45140000 -STD 2,385 (500) Cr 2,385 (501) P 3,160 (508) 6,335 () 6,335 ()	ø31,8 x 75,3			

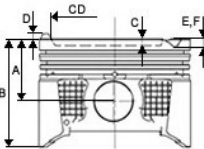





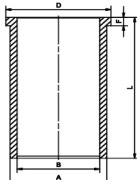

							
Motor /Engine	Ref. No. Kit 1	Ölçüler /Dimensions	Segman /Rings	Pim	Gömlek /Liner	Kit 2	Info
<p>ø92,00</p> <p>5. Cyl. Diesel cc</p> <p>WJ 3.1 L TD <u>1999 - 2001</u> CHEROKEE WJ 3.1 L TD</p>	<p>17-9792100 STD 17-9792103 0.50</p>	<p>A = 51,200 B = 81,300 C = 3,870 E = -2,700</p> <p>Segman Taşıyıcı (Ring Carrier)</p> <p>Sert Anotlama (Hard Anodising)</p> <p>Yag Galerisi (Oil Gallery)</p>	<p>RK97209200010 -STD</p> <p>2,500 () CK P 1,500 () P 2,000 () NT</p>	<p>ø30,0 x 70,0</p>			
<p>ø93,00</p> <p>8 Cyl. Benzin 4700 cc</p> <p>CPW6925 8V 4.7LT Power Tech V8 <u>1999 - 2007</u> Dakota (AN) 2000/2007 Durango (DN) 2000/2007 Commander (XK/XH) 2006/2007 Grand Cherokee (WJ/WG/WK/WH) 1999-2007 Ram1500 Pickup 2002/2007 Raider 2006/2007</p>	<p>17-9710320 STD 17-9710323 0.50</p>	<p>A = 31,800 B = 53,800</p>	<p>RK97109300010 -STD RK97109300013 -0.50</p> <p>1,500 () GI 1,500 () Cr 3,000 () Cr</p>	<p>ø24,0 x 59,0</p>			



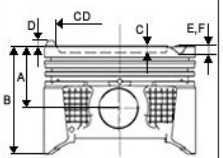









							
Motor /Engine	Ref. No. Kit 1	Ölçüler /Dimensions	Segman /Rings	Pim	Gömlek /Liner	Kit 2	Info
<p>ø94,00</p> <p>4 Cyl. Diesel 2800 cc 180 ps 2.8 HP DODGE NITRO</p> <p>2.8 HP DODGE NITRO 2007/2008 GRAND KARAVAN IV 2008-2010 JEEP LIBERTE/CHEROKEE (KK) 2008-2009 CHEROKEE WRANGLER (JK) 2007-... CHRYSLER VOYAGER/VILLE&PAYS 2008-2010</p>	<p>18-9792010 STD 18-9792013 0.50</p>	<p>A = 52,000 B = 80,000 C = 17,000 E = -1,000 F = -1,000 CD= 52,200</p> <p>Segman Taşıyıcı (Ring Carrier)</p> <p>Yag Galerisi (Oil Gallery)</p>	<p>RE04000000 -STD RE04000050 -0.50</p> <p>2,500 (500) Cr P 1,500 (501) P 2,000 (2)G GN</p>	<p>ø32,0 x 74,0</p>			
							

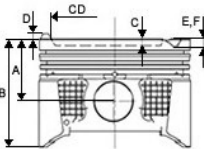





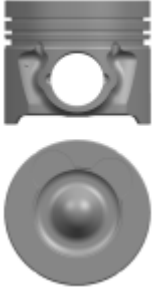

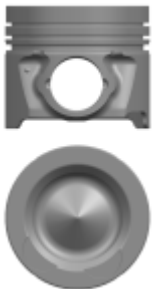
							
Motor /Engine	Ref. No. Kit 1	Ölçüler /Dimensions	Segman /Rings	Pim	Gömlek /Liner	Kit 2	Info
<p>ø71,50</p> <p>4 Cyl. Benzin 1300 cc 75 Ps G4K G4EA</p> <p><u>2000 -....</u></p> <p>Accent 1,3</p>	<p>18-4011060 STD 18-4011063 0.50</p>	<p>A = 30,800 B = 53,900 C = 0,700 E = -2,200 CD= 57,900</p>	<p>RJ40770A00 -STD RJ40770C00 -0.50 RJ40770D00 -0.75</p> <p>1,500 () FV 1,500 () 3,000 ()</p>	<p>ø18,0 x 47,5</p>	<p>G71501320K_1</p> <p>A= 74,500 B= 70,800 D= 76,000 F= 5,000 H= 0,000 L= 132,000</p> 		
<p>ø72,00</p> <p>4 Cyl. Benzin 74/76 Kw (101/103 Ps) G4LC</p> <p><u>2014 -</u></p> <p>Accent Accent Blue i20 i20 Coupe i30 i30 CW</p>	<p>18-4011080 STD 18-4011083 0.50</p>	<p>A = 24,700 B = 42,700 C = 3,600 E = -2,500</p>	<p>RJ40008A00 -STD RJ40008C00 -0.50</p> <p>1,000 () 1,200 () 2,000 ()</p>	<p>ø18,0 x 48,0</p>			



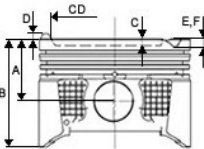



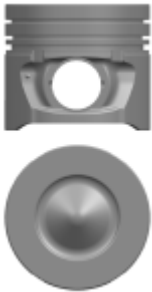
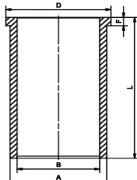
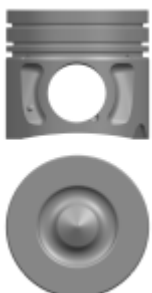

							
Motor /Engine	Ref. No. Kit 1	Ölçüler /Dimensions	Segman /Rings	Pim	Gömlek /Liner	Kit 2	Info
<p>ø75,50</p> <p>4 Cyl. Benzin 1399 cc 97 PS 10:1 G4EE <u>2005 -</u> 1.4 DOCH AccentEra 1.4 16v</p>	<p>18-4011070 STD 18-4011073 0.50</p> 	<p>A = 28,750 B = 47,900 D = 2,200 E = -2,950</p>	<p>RJ40112A00 -STD RJ40112C00 -0.50</p> <p>1,200 () SV 1,200 () 2,000 () GN</p>	<p>ø18,0 x 47,9</p>	<p>G75501320K_1</p> <p>A= 78,500 B= 74,800 D= 79,500 F= 5,000 H= 0,000 L= 132,000</p> 		
<p>ø77,00</p> <p>4 Cyl. Benzin 1591 cc 130kW 170 PS G4FJ <u>2015 - 2019</u></p> <p>i 30 KONA TUSCON VELOSTER CEED OPTIMA PROCEED SELTOS SOUL II/III SPORTAGE XCEED</p>	<p>18-4010020 STD 18-4010023 0.50</p> 	<p>A = 27,900 B = 45,000 C = 3,000 E = -2,300 F = -3,300 CD= 69,200</p> <p>Segman Taşıyıcı (Ring Carrier)</p>	<p>RJ39931A00 -STD RJ39931C00 -0.50</p> <p>1,200 () 1,500 () 2,000 ()</p>	<p>ø20,0 x 52,0</p>			



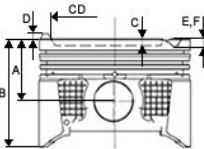





Motor /Engine	Ref. No. Kit 1	Ölçüler /Dimensions	Segman /Rings	Pim	Gömlek /Liner	Kit 2	Info
							
ø77,00 4 Cyl. Benzin 1591 cc 137kW 186 PS 2017 Sonrası G4FJ 2017 - i 30 i30 COUPE KONA TUSCON VELOSTER	18-4010030 STD 18-4010033 0.50	A = 28,000 B = 45,000 C = 3,200 E = -2,200 F = -2,900 CD= 39,100 Segman Taşıyıcı (Ring Carrier)	RJ39931A00 -STD RJ39931C00 -0.50 1,200 () 1,500 () 2,000 ()	ø20,0 x 52,0			
ø77,00 4 Cyl. Benzin 1396 cc 66/73/74 KW 87/90/100/101 PS G4FA 2009 -.... Accent 1,4 16v i20 1,4 16v i30 1,4 16v	18-4011200 STD 18-4011203 0.50	A = 26,900 B = 43,900 C = 1,400 E = -3,100	RJ40166A00 -STD RJ40166C00 -0.50 1,200 () SV 1,200 () 2,000 ()	ø18,0 x 52,3			



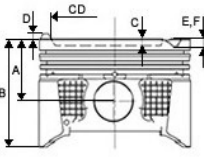





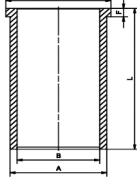



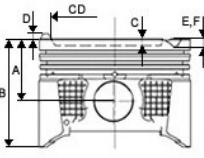



							
Motor /Engine	Ref. No. Kit 1	Ölçüler /Dimensions	Segman /Rings	Pim	Gömlek /Liner	Kit 2	Info
<p>ø77,20</p> <p>4 Cyl. Diesel 1582 cc 84kW 115PS 17:3 D4FB 1.6 CRDi <u>2007 -</u> I30 Cerato</p>	<p>18-4092530 STD 18-4092533 0.50</p> 	<p>A = 41,950 B = 65,700 C = 12,700 E = -0,500 CD= 44,000</p> <p>1,750 () 1,750 () 3,000 ()</p> <p>Segman Taşıyıcı (Ring Carrier)</p> <p>Yag Galerisi (Oil Gallery)</p>	<p>RJ40274A00 -STD RJ40274C00 -0.50</p> <p>1,750 () 1,750 () 3,000 ()</p>	<p>ø28,0 x 62,0</p>	<p>G77201400K_1</p> <p>A= 80,200 B= 76,500 D= 81,700 F= 5,000 H= 0,000 L= 140,000</p> 		
<p>ø77,20</p> <p>4 Cyl. Diesel 1582 cc 100kW 136PS D4FB 1.6 CRDi <u>2015 -</u> 1.6 CRDI I30 2015....</p>	<p>18-4092580 STD 18-4092583 0.50</p> 	<p>A = 42,000 B = 65,700 C = 12,600 E = -0,600 CD= 47,100</p> <p>1,750 () 1,750 () 3,000 ()</p> <p>Segman Taşıyıcı (Ring Carrier)</p> <p>Sert Anotlama (Hard Anodising)</p> <p>Yag Galerisi (Oil Gallery)</p>	<p>RJ40274A00 -STD RJ40274C00 -0.50</p> <p>1,750 () 1,750 () 3,000 ()</p>	<p>ø28,0 x 64,0</p>			

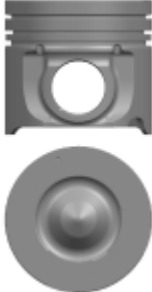
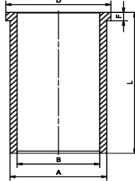
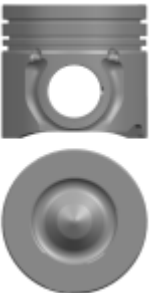



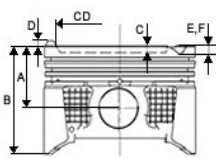
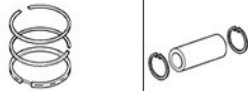

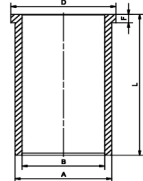
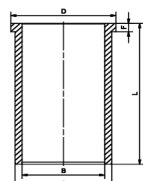

							
Motor /Engine	Ref. No. Kit 1	Ölçüler /Dimensions	Segman /Rings	Pim	Gömlek /Liner	Kit 2	Info
<p>ø83,00</p> <p>3/4 Cyl. Diesel 1493/1991 cc (-0.20 mm) 60/82/100 Kw (82/112 Ps) 17.7:11 D3EA D4EA <u>2001 -</u></p> <p>Accent 1.5 CRDI Getz 1.5 CRDI Tuscon 2.0 CRDI Santa FE 2.0 CRDI Sportage 2. CRDI Carens 2.0 CRDI</p>	<p>17-4094540 STD 17-4094540-20 STD (-0.20 mm) 17-4094543 0.50 17-4094543-20 0.50 (-0.20 mm)</p> 	<p>A = 46,300 B = 72,300 C = 13,900 CD= 46,950</p> <p>Segman Taşıyıcı (Ring Carrier)</p> <p>Yag Püskürt. Oyugu (Oil Cut-Out)</p> <p>Burc (Bushing)</p>	<p>RJ39597A00 -STD RJ39597C00 -0.50</p> <p>2,000 () 2,000 () 3,000 ()</p>	<p>ø28,0 x 65,5</p>	<p>G83001550K_1</p> <p>A= 83,000 B= 79,300 D= 85,000 F= 5,000 H= 0,000 L= 155,000</p> 		
<p>ø84,00</p> <p>4 Cyl. Diesel 1995 cc /100 Kw (1362 Ps) 16,51 D4HA <u>2009 -</u></p> <p>IX35 Santa FE 2.0 Sorento Sportage</p>	<p>18-4092560 STD 18-4092563 0.50</p> 	<p>A = 48,900 B = 75,900 C = 15,700 CD= 45,400</p> <p>Segman Taşıyıcı (Ring Carrier)</p> <p>Yag Galerisi (Oil Gallery)</p> <p>Yag Püskürt. Oyugu (Oil Cut-Out)</p>	<p>RJ40026A00 -STD RJ40026C00 -0.50</p> <p>2,500 () 2,000 () 3,000 ()</p>	<p>ø36,0 x 80,8</p>			



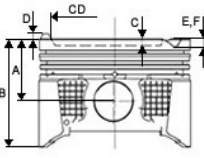





							
Motor /Engine	Ref. No. Kit 1	Ölçüler /Dimensions	Segman /Rings	Pim	Gömlek /Liner	Kit 2	Info
<p>ø85,40</p> <p>4 Cyl. Diesel 2199 cc 147kW 200PS D4HB <u>2009 -</u> Sorento II-III</p>	<p>18-4092570 STD 18-4092573 0.50</p>	<p>A = 49,900 B = 76,900 C = 16,100 CD= 47,400</p> <p>Segman Taşıyıcı (Ring Carrier)</p> <p>Yag Galerisi (Oil Gallery)</p> <p>Yag Püskürt. Oyugu (Oil Cut-Out)</p>		<p>ø36,0 x 80,8</p>			
<p>ø86,50</p> <p>4 Cyl. Diesel 2184 cc 22,9:1 R2 <u>1997 -</u> Besta Yeni Tip Crew Cap E 2200 Van/Pick Up</p>	<p>18-9050010 STD 18-9050013 0.50</p>	<p>A = 47,350 B = 86,150 C = 1,600</p> <p>Segman Taşıyıcı (Ring Carrier)</p> <p>Yag Galerisi (Oil Gallery)</p> <p>Sac Plaka (Steel Support)</p>	<p>RJ30855A00 -STD RJ30855C00 -0.50</p> <p>2,000 () RN Cr1 FX 2,000 () 4,000 ()</p>	<p>ø25,0 x 68,0</p>			



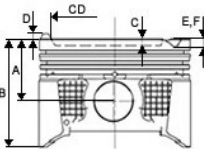





							
Motor /Engine	Ref. No. Kit 1	Ölçüler /Dimensions	Segman /Rings	Pim	Gömlek /Liner	Kit 2	Info
<p>ø86,50</p> <p>4 Sil 1984 cc 85 kW 115/116 PS 10,4:1 10,5:1 ,8 Ventile AEG APK AQY <u>1998-2008</u></p> <p><i>Besta Eski Model Crew Cap E2200 Van Pick Up</i></p>	<p>18-9050020 STD 18-9050023 0.50</p>	<p>A = 47,350 B = 86,150 C = 1,600</p> <p>Segman Taşıyıcı (Ring Carrier)</p> <p>Sac Plaka (Steel Support)</p>	<p>RJ30855A00 -STD RJ30855C00 -0.50</p> <p>2,000 () RN Cr1 FX 2,000 () 4,000 ()</p>	<p>ø25,0 x 68,0</p>	<p>G86001650K_1</p> <p>A= 89,600 B= 85,300 D= 91,500 F= 5,000 H= 0,000 L= 165,000</p> 		
<p>ø88,94</p> <p>4 Cyl. Diesel 2367 cc 53 kW 72PS S2-..... Ceres 2400</p>	<p>18-4050090 STD 18-4050093 0.50</p>	<p>A = 50,750 B = 94,650 C = 1,700</p> <p>Segman Taşıyıcı (Ring Carrier)</p> <p>Sac Plaka (Steel Support)</p>	<p>RJ40043A00 -STD RJ40043C00 -0.50</p> <p>2,383 () 2,383 () 4,763 ()</p>	<p>ø28,0 x 73,0</p>			

							
Motor /Engine	Ref. No. Kit 1	Ölçüler /Dimensions	Segman /Rings	Pim	Gömlek /Liner	Kit 2	Info
<p>ø91,00</p> <p>4 Cyl. Diesel 2497 cc 74/95 Kw (110/129 Ps) D4CB CRDI 2002 -.... Starex 2.5 CRDI Sorento</p>	<p>18-4050050 STD 18-4050053 0.50</p> 	<p>A = 54,250 B = 83,750 C = 15,000 E = -0,300 CD= 52,000</p> <p>Segman Taşıyıcı (Ring Carrier)</p> <p>Yag Galerisi (Oil Gallery)</p> <p>Yag Püskürt. Oyugu (Oil Cut-Out)</p>	<p>RJ39613A00 -STD RJ39613C00 -0.50</p> <p>2,500 () 2,000 () 3,000 ()</p>	<p>ø33,0 x 75,0</p>	<p>G91001700KD_1</p> <p>A= 94,200 B= 90,300 D= 0,000 F= 0,000 H= 0,000 L= 170,000</p> 		<p>+ 0,06 + 0,24</p>
<p>ø91,00</p> <p>4 Cyl. Diesel 2497 cc 125 Kw (170 BG) D4BC-.... Stratex 2.5 CRDI</p>	<p>18-4094900 STD 18-4094903 0.50</p> 	<p>A = 54,250 B = 83,700 C = 15,000 E = -0,340 CD= 52,000</p> <p>Segman Taşıyıcı (Ring Carrier)</p> <p>Yag Galerisi (Oil Gallery)</p> <p>Yag Püskürt. Oyugu (Oil Cut-Out)</p> <p>Burc (Bushing)</p>	<p>RJ39613A00 -STD RJ39613C00 -0.50</p> <p>2,500 () 2,000 () 3,000 ()</p>	<p>ø33,0 x 74,0</p>			

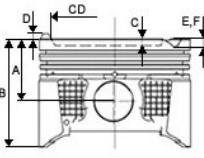





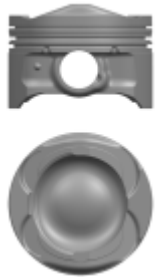
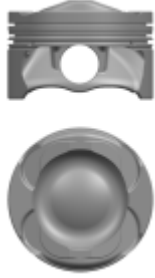

Motor /Engine	Ref. No. Kit 1	Ölçüler /Dimensions	Segman /Rings	Pim	Gömlek /Liner	Kit 2	Info
							
ø91,10 4 Cyl. Diesel 2467 cc 73 78 Kw (99 106) Ps D4BH 2000 -..... 2. & 4. Sil. Turbo Intercooler K2500 TCI Bongo Starex 2500 TCI	17-4050020 STD 17-4050020-20 STD (-0.20 mm) 17-4050023 0.50 17-4050023-20 0.50 (-0.20 mm) 17-4050028 1.00 17-4050028-20 1.00 (-0.20 mm)	A = 48,700 B = 88,700 C = 1,300 Segman Taşıyıcı (Ring Carrier) Yag Galerisi (Oil Gallery) Sac Plaka (Steel Support)	RJ40699A00 -STD RJ40699C00 -0.50 2,500 () RN FM 1,950 () RN 4,000 ()	ø29,0 x 75,0	G91101647K_1 A= 94,130 B= 90,400 D= 96,000 F= 5,000 H= 0,000 L= 164,750 		+ 0,50 + 0,60
ø91,10 4 Cyl. Diesel 2467 cc 73 78 Kw (99 106) Ps D4BH 2000 -..... 1. & 3. Sil. Turbo Intercooler K2500 TCI Bongo Starex 2500 TCI	17-4050030 STD 17-4050030-20 STD (-0.20 mm) 17-4050033 0.50 17-4050033-20 0.50 (-0.20 mm) 17-4050038 1.00 17-4050038-20 1.00 (-0.20 mm)	A = 48,700 B = 88,700 C = 1,300 Segman Taşıyıcı (Ring Carrier) Yag Galerisi (Oil Gallery) Sac Plaka (Steel Support)	RJ40699A00 -STD RJ40699C00 -0.50 2,500 () RN FM 1,950 () RN 4,000 ()	ø29,0 x 75,0	G91101647K_1 A= 94,130 B= 90,400 D= 96,000 F= 5,000 H= 0,000 L= 164,750 		+ 0,50 + 0,60



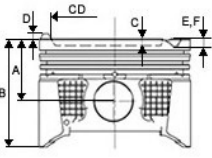



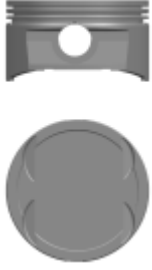
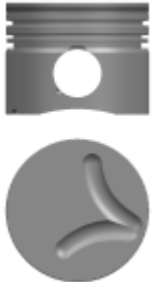

							
Motor /Engine	Ref. No. Kit 1	Ölçüler /Dimensions	Segman /Rings	Pim	Gömlek /Liner	Kit 2	Info
<p>ø92,04</p> <p>4 Cyl. Diesel 2367 cc 53 kW 72PS 21,7:1 SF2400-..... Ceres K2400</p>	<p>18-4050600 STD 18-4050603 0.50</p>	<p>A = 50,600 B = 94,600 C = 1,950</p> <p>Segman Taşıyıcı (Ring Carrier)</p> <p>Sac Plaka (Steel Support)</p>		<p>ø29,0 x 68,0</p>			
<p>ø93,00</p> <p>4 Cyl. Diesel 2662 cc 80PS NV 1997 - Hi-Besta K2700</p>	<p>18-4092950 STD 18-4092950-20 STD (-0.20 mm) 18-4092953 0.50 18-4092953-20 0.50 (-0.20 mm)</p>	<p>A = 48,250 B = 85,150 C = 1,700</p> <p>Segman Taşıyıcı (Ring Carrier)</p> <p>Yag Galerisi (Oil Gallery)</p> <p>Sac Plaka (Steel Support)</p> <p>Yag Püskürt. Oyugu (Oil Cut-Out)</p>	<p>RJ40513A00 -STD RJ40513C00 -0.50</p> <p>2,000 () 2,000 () 3,000 () GN</p>	<p>ø30,0 x 76,0</p>			



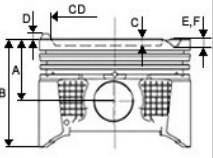



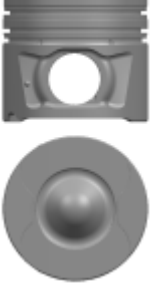
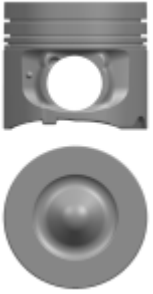

							
Motor /Engine	Ref. No. Kit 1	Ölçüler /Dimensions	Segman /Rings	Pim	Gömlek /Liner	Kit 2	Info
<p>ø94,55</p> <p>4 Cyl. Diesel 2665 cc 61 Kw (83 Ps) J20HC(JS) (K2700) <u>1997 -....</u> Bongo 2.7 Pregio</p>	<p>18-4050010 STD</p> <p>18-4050010-20 STD (-0.20 mm)</p> <p>18-4050013 0.50</p> <p>18-4050013-20 0.50 (-0.20 mm)</p>	<p>A = 50,000 B = 81,650 C = 2,000</p> <p>Segman Taşıyıcı (Ring Carrier)</p> <p>Sac Plaka (Steel Support)</p> <p>Yag Püskürt. Oyugu (Oil Cut-Out)</p>	<p>RJ40025A00 -STD RJ40025C00 -0.50</p> <p>2,000 () CrI 2,000 () CrI 3,000 () GN</p>	<p>ø30,0 x 76,0</p>			
<p>ø100,00</p> <p>4 Cyl. Diesel K3500 KHVD 115 AO <u>.... -....</u> K3500 KHVD 115 AO Kamyon Kobra</p>	<p>18-4051970 STD</p>	<p>A = 60,730 B = 110,730 C = 19,000 CD= 50,700</p> <p>Sac Plaka (Steel Support)</p>	<p>RJ30045A00 -STD</p> <p>2,500 () RN Cr2 FX 2,000 () 4,500 ()</p>	<p>ø34,0 x 81,9</p>			



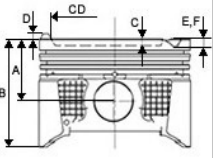





							
Motor /Engine	Ref. No. Kit 1	Ölçüler /Dimensions	Segman /Rings	Pim	Gömlek /Liner	Kit 2	Info
<p>ø79,00</p> <p>4 Cyl. Benzin 1600 cc</p> <p>GÜÇLENDİRİLMİŞ 1.6 EcoBoost</p> <p>.....-.....</p> <p>1.6 EcoBoost</p>	<p>18-2510440 STD</p> <p>18-2510440-30 STD</p> <p>18-2510443 0.50</p> <p>18-2510443-30 0.50</p> <p>18-2510448 1.00</p> <p>18-2510448-30 1.00</p>	<p>A = 28,650</p> <p>B = 54,000</p> <p>C = 5,100</p> <p>D = 6,350</p> <p>E = -3,190</p> <p>F = -2,430</p> <p>CD= 53,500</p> <p>Segman Taşıyıcı (Ring Carrier)</p> <p>Sert Anotlama (Hard Anodising)</p>	<p>RE43490000 -STD</p> <p>RE43490050 -0.50</p> <p>RE43490100 -1.00</p> <p>1,200 (500) NitB S</p> <p>1,200 (501) P</p> <p>2,000 (700) Cr P S</p>	<p>ø21,0 x 46,0</p>			
<p>ø79,00</p> <p>4 Cyl. Benzin 1600 cc</p> <p>1.6 EcoBoost KOL ARASI DÜZ</p> <p>.....-.....</p> <p>1.6 EcoBoost</p>	<p>18-2510460 STD</p> <p>18-2510463 0.50</p> <p>18-2510468 1.00</p>	<p>A = 29,700</p> <p>B = 57,500</p> <p>C = 5,200</p> <p>D = 6,320</p> <p>E = -3,200</p> <p>F = -2,500</p> <p>CD= 53,500</p> <p>Sert Anotlama (Hard Anodising)</p>	<p>RE23080000 -STD</p> <p>RE23080050 -0.50</p> <p>1,200 (500) NitB S</p> <p>1,500 (508) P</p> <p>2,000 (700) Nit S</p>	<p>ø21,0 x 57,0</p>			



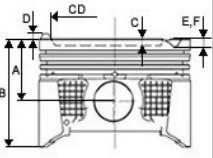









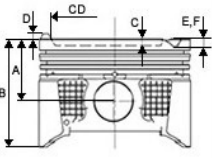



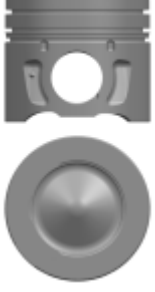
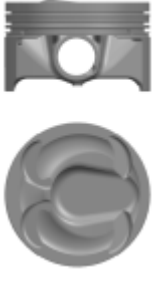

Motor /Engine	Ref. No. Kit 1	Ölçüler /Dimensions	Segman /Rings	Pim	Gömlek /Liner	Kit 2	Info
       							
ø80,00 4 Cyl. Benzin 1588/1796 cc 79/80/83 85/86/88 kW 10/109/113/116 117/120 PS 10.5:1 18 K4K VVC 16 K4F K 1.8 <u>11/95 - 05/05</u> 25 1.8 16v 200 218 K Vi 400 Tourer 1.8i Coupe 1.8 16V Freelander (1.8 16V 1.8 i 16V Soft Top 1.8 Soft Top 1.8 i (16V) Elise 1.8 Seven 1.8 MGF (1.6-1.8)	18-6510080 STD 18-6510083 0.50	A = 22,700 B = 45,650 C = 0,530 E = -2,650 CD= 68,200	RE70050000 -STD RE70050050 -0.50 1,000 (500) Nit S IF 1,200 (508) P 2,000 (700) Nit S	ø18,0 x 53,0			
							
ø80,00 4/6 Cyl. Diesel 1669/2498 cc 105 Kw (90/143 Ps) M41/M51 D25WA/BMW 25 6T X 25 DT/TD 25 LT <u>1990 -....</u> Turbo Intercooler 318 Compact TDS/TouringSE 325 325/525 TDS/Touring 725 TDS Omega TDS Range Rover	17-6592090 STD 17-6592093 0.50	A = 39,450 B = 62,450 C = 2,500	RE15140000 -STD RE15140050 -0.50 RE15140100 -1.00 3,000 (504) Cr 1,750 (501) P IFU 3,000 (604) Cr	ø27,0 x 63,0			
		Segman Taşıyıcı (Ring Carrier) Yag Galerisi (Oil Gallery) Sac Plaka (Steel Support) Yag Püskürt. Oyugu (Oil Cut-Out)					



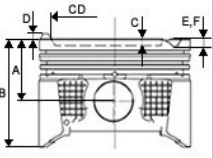



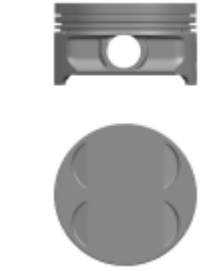

Motor /Engine	Ref. No. Kit 1	Ölçüler /Dimensions	Segman /Rings	Pim	Gömlek /Liner	Kit 2	Info
       							
ø81,00 4/6/8 Cyl. Diesel 2720cc 150/200 KW(204/272 PS) 2.7 Lion TVM 276DT 368DT 2008 - DISCOVERY 2.7 TDI RANGE ROVER 2.7TDV6 (2008 -) RANGE ROVER SPORT (L320) 3,6 D 4x4 (04,2006 - 03,2013)	17-6592100 STD 17-6592103 0.50	A = 47,000 B = 71,000 C = 14,050 E = -0,500 CD= 44,000 Segman Taşıyıcı (Ring Carrier) Yag Galerisi (Oil Gallery)	RE47570000 -STD RE47570050 -0.50 2,000 (500) Cr PIF 2,000 (501) P IFU 2,000 (604) Nit S	ø29,0 x 62,0			
							
ø83,00 4 Cyl. Diesel 1997/1998/1999 cc 110/120/132/147 177 KW 150/163/179/180 200/204 PS 204DTA/D AJ20D4 AJ200D 2.0 INGENIUM TURBO DIESEL 2.0D 2.0 D/TD4/150/165/180 4x4 2.0 D AWD 2014 - XF/II/SPORTBRAKE (260) XE (760) F PACE (761) E PACE (X540) XJ DISCOVERY SPORT (L550) RANGE ROVER EVOQUE (L538/L551) DISCOVERY V(L462)	18-6592150 STD 18-6592153 0.50	A = 47,000 B = 73,600 C = 16,100 CD= 48,000 Segman Taşıyıcı (Ring Carrier) Yag Galerisi (Oil Gallery)	RE43510000 -STD RE43510040 -0.40 RE43510050 -0.50 1,500 (500) Cr P 1,500 (508) P 2,000 (604) Nit S	ø32,0 x 65,0			
							



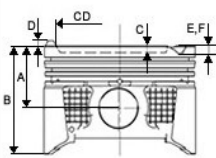



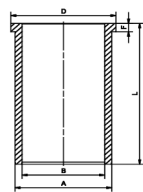
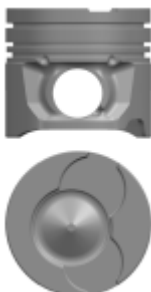

Motor /Engine	Ref. No. Kit 1	Ölçüler /Dimensions	Segman /Rings	Pim	Gömlek /Liner	Kit 2	Info
							
ø84,00 6 Cyl. Diesel 2993 cc 155 KW 150 HP 3.0L AJD V6 DT20 <u>2010 -....</u> DISCOVERY IV	17-6592220 STD 17-6592223 0.50	A = 46,000 B = 70,000 C = 15,350 CD= 47,620 Segman Taşıyıcı (Ring Carrier) Yag Galerisi (Oil Gallery) Yag Püskürt. Oyugu (Oil Cut-Out)	RE15440000 -STD RE15440050 -0.50 1,750 (500) Cr P 1,750 (508) P 2,000 (604) Nit S	ø30,0 x 63,7			
ø84,00 4/6 Cyl. Diesel 2926 cc 135 Kw (184 Ps) M57D30 M47D20R TD6 <u>1999 -....</u> Freelander Range Rover TD6 2002	17-6592960 STD 17-6592963 0.50	A = 47,000 C = 16,500 E = -1,360 F = -1,480 G = 71,000 CD= 41,550 Segman Taşıyıcı (Ring Carrier) Yag Galerisi (Oil Gallery)	RE15410000 -STD RE15410050 -0.50 3,000 (504) Cr 2,000 (508) P 3,000 (604) Cr P	ø30,0 x 68,0			1. Kertik conta +0,80 +0,90 2. Kertik conta +0,90 +1,00



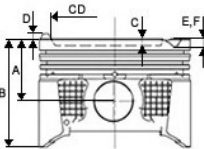



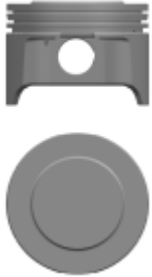

Motor /Engine	Ref. No. Kit 1	Ölçüler /Dimensions	Segman /Rings	Pim	Gömlek /Liner	Kit 2	Info
       							
ø84,45 4 Cyl. Diesel 1944 cc 74/83/63/72 kW 86/113 PS 20T2N (L Series) 20T2R (L Series) Turbo Intercooled <u>12/94 - 10/06</u> 25-40 2.0i DT 220 SD 220 SDI 420 SD 420 SDI 620 SDI Streetwise 2.0 TD Freelander (Soft Top) 2.0DI Accord V-VI 2.0 TDI Civic VI 2.0 TDiC (Aerodeck) D-TDiC MG ZR/ZS 2.0 Express 2.0 TD	18-6550900 STD 18-6550903 0.50	A = 47,970 B = 76,970 C = 17,000 CD= 38,000 Segman Taşıyıcı (Ring Carrier)	RE70070000 -STD RE70070050 -0.50 3,000 (504) Cr P2 (508)P 3,000 (604) Cr P S	ø30,0 x 70,0			
ø84,45 5 Cyl. Diesel 2495 cc 90 102 Kw TD5 Range Rover <u>1998 -....</u> Discovery 2.5 TD5 Adventurer Discovery 1994>	17-6592980 STD 17-6592983 0.50	A = 47,850 B = 79,000 C = 17,400 CD= 39,000 Segman Taşıyıcı (Ring Carrier) Yag Galerisi (Oil Gallery) Yag Püskürt. Oyugu (Oil Cut-Out)	RE35020000 -STD RE35020050 -STD 3,000 (503) Cr S 2,000 (508) P 3,000 (604) Cr P S	ø30,0 x 70,0			



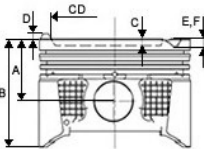





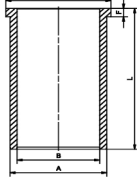

Motor /Engine	Ref. No. Kit 1	Ölçüler /Dimensions	Segman /Rings	Pim	Gömlek /Liner	Kit 2	Info
							
ø85,00 4/6 Cyl. Diesel 2179 cc 110 KW 211 PS DW12BTED4 2011 - 2013 FREELANDER 2 2.2 TD4	17-6592300 STD 17-6592303 0.50	A = 48,705 B = 74,705 C = 13,475 E = -0,385 CD= 52,400 Segman Taşıyıcı (Ring Carrier) Yag Galerisi (Oil Gallery) Yag Püskürt. Oyugu (Oil Cut-Out)	RE35000000 -STD RE35000050 -0.50 2,500 (505) Cr P 2,000 (501) P IFU 2,000 (604) Nit S	ø30,0 x 68,0			
							
ø87,52 4 Cyl. Benzin 1999 cc 176/177/179 KW 239/240/241/243 PS 2.0 EcoBoost TPBA 204PT Euro 5 2.0 4x4 B 4204 T7 T5 2010 - 2015 2.0 EcoBoost Discovery Sport L550 Range R. Evoque Cabriolet L538 Freelander 2 L359/LF S60 II 134/124 V60 155/157 V70 III 135 XC60 156	18-2510320 STD 18-2510323 0.50	A = 32,800 B = 53,800 D = 2,190 Sert Anotlama (Hard Anodising)	RK25187500010 -STD RK25187500013 -0.50 1,200 () Cr S P 1,200 () S P 2,000 () Nit S	ø22,5 x 56,0			

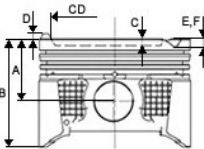





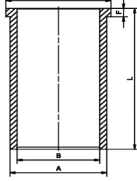



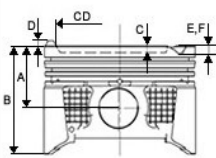

Motor /Engine	Ref. No. Kit 1	Ölçüler /Dimensions	Segman /Rings	Pim	Gömlek /Liner	Kit 2	Info
							
ø90,48 4 Cyl. Diesel 2486 cc 83 Kw (113 Ps) 19,3:1 300 TDi 1994 -.... Defender 110 Defender 130 Defender 90 1994	18-6593010 STD 18-6593013 0.50 18-6593018 1.00	A = 55,400 B = 92,000 C = 18,450 CD= 39,000 Segman Taşıyıcı (Ring Carrier)	RE35050000 -STD RE35050050 -0.50 RE35050100 -1.00 3,000 (505) Mo 2,500 (508) P 3,000 (604) Cr P	ø30,2 x 77,0			1. çentik conta + 0,50 + 0,60 2. çentik conta + 0,61 + 0,70 3. çentik conta + 0,71 + 0,80
ø92,00 8 Cyl. Benzin 4395cc 210/212 kW/286 PS M62 B44 LEV 1996 -.... 540i 740i 840i X5 RANGE ROVER III 4.4	17-5510010 STD 17-5510013 0.50	A = 31,300 E = -2,950 F = -53,300 Sert Anotlama (Hard Anodising)	RE15450000 -STD RE15450050 -0.50 RE15450100 -1.00 1,500 (500) Nit S 1,500 (508) P 2,000 (700) Nit S	ø22,0 x 60,0			
							







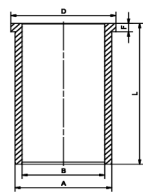

Motor /Engine	Ref. No. Kit 1	Ölçüler /Dimensions	Segman /Rings	Pim	Gömlek /Liner	Kit 2	Info
							
ø71,91 4 Cyl. Benzin, 1242 cm ³ 55 kW (75 hp) ZtecS DHA DHB DHC DHD DHE DHF DHG ZH12 <u>1995-2013</u> Fiesta 1.2 16v Focus 1.2 16v Mazda 121	18-2510860 STD 18-2510863 0.50	A = 28,250 B = 53,250 C = 0,930 CD= 52,000	RE23480000 -STD RE23480050 -0.50 1,200 (500) CrB P S IF 1,500 (508) P 2,500 (700) Cr P S	ø19,0 x 50,0			
							
ø73,70 4 Cyl. Diesel 1399 cc 50 Kw (68 Ps) DV4TD DV4 TED DV4C TED F6JA F6JB 8HX 8HR 8HZ 8HS <u>2002 -....</u> Fiesta V 1.4 TDCI Fusion 1.4 TDCI Mazda 2 1.4D C2 1.4 HDI C3 1.4 HDI Xsara 1.4 HDI NEMO 1.4 HDI 1007 1.4 HDI 107 1.4 HDI 206 1.4 HDI 207 1.4 HDI 307 1.4 HDI BIPPER 1.4 HDI	18-2550150 STD 18-2550150-20 STD (-0.20 mm) 18-2550150-40 STD (-0.40 mm) 18-2550153 0.50 18-2550153-20 0.50 (-0.20 mm) 18-2550153-40 0.50 (-0.40 mm)	A = 42,940 B = 65,440 C = 14,700 E = -1,550 CD= 37,600 Segman Taşıyıcı (Ring Carrier) Yağ Püskürt. Oyugu (Oil Cut-Out)	RK25273700010 -STD RK25273700013 -0.50 2,500 (505) CrB P 1,950 (508) P IFU 2,500 (604) Cr P	ø25,0 x 60,0	G76701360K_1 A= 76,700 B= 73,000 D= 78,200 F= 5,000 H= 0,000 L= 136,000 	1 çentik 1,351mm conta +0,776 +0,825 2 çentik 1,252mm conta +0,618 +0,725 3 çentik 1,303mm conta +0,726 +0,775 4 çentik 1,400mm conta +0,83 +0,88 5 çentik 1,450mm conta +0,88 0,98	
							



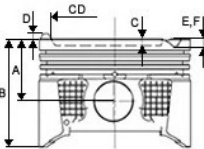
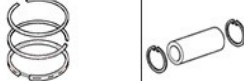

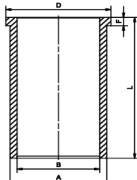

							
Motor /Engine	Ref. No. Kit 1	Ölçüler /Dimensions	Segman /Rings	Pim	Gömlek /Liner	Kit 2	Info
<p>ø73,94</p> <p>4 Cyl. Benzin, 1297 cm³ 44 kW (60 hp)</p> <p>J4C J4D J4J J4K J4L J4M J4N J4P J4Q J4R J4S J4T JB</p> <p><u>1988-1992</u></p> <p><i>Escort IV 1.3</i> <i>Fiesta IV 1.3</i></p> 	<p>18-2510770 STD 18-2510773 0.50 18-2510778 1.00</p>	<p>A = 29,400 B = 53,900</p>	<p>RE23010000 -STD RE23010050 -0.50 RE23010100 -1.00</p> <p>1,500 (500) Cr S IF 1,750 (508) P 3,000 (700) Cr P S</p>	<p>ø18,0 x 64,0</p>			
<p>ø76,00</p> <p>4 Cyl. Benzin 1400cc 80 Ps</p> <p>FXDA FXDB FXDC FXJA FXJB</p> <p><u>2002 - 2011</u></p> <p><i>Fiesta 1.4</i> <i>Puma 1.4</i> <i>Mazda 2 1,4i 16v</i> <i>Mazda 3 1,4i 16v</i></p> 	<p>18-2510870 STD 18-2510873 0.50</p>	<p>A = 28,250 B = 55,500 D = 1,250</p>	<p>RE23540000 -STD RE23540050 -0.50</p> <p>1,200 (500) NitB S 1,500 (501) P 2,500 (700) Nit S</p>	<p>ø19,0 x 50,0</p>			





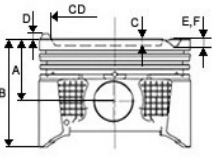
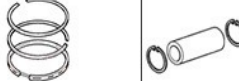

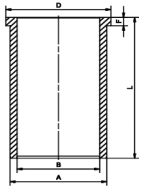
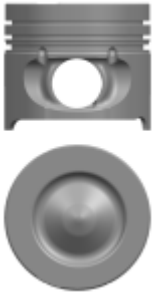

							
Motor /Engine	Ref. No. Kit 1	Ölçüler /Dimensions	Segman /Rings	Pim	Gömlek /Liner	Kit 2	Info
<p>ø82,50</p> <p>4 Cyl. Diesel, 1753 cm³ 44 kW (60 hp), 21,5:1 RTA RTB RTC RTD RTE RTF RTG RTH RTJ</p> <p><u>1988-1994</u></p> <p><i>Fiesta D Escort D Orion D Mazda 121 1,8D</i></p>	<p>18-2550910 STD 18-2550913 0.50</p>	<p>A = 45,700 B = 73,700 C = 1,600</p> <p>Segman Taşıyıcı (Ring Carrier)</p>	<p>RE43150000 -STD RE43150050 -0.50 RE43150100 -1.00</p> <p>2,000 (500) Cr 2,000 (501) P 3,000 (604) Cr</p>	<p>ø26,0 x 69,0</p>	<p>G82501460K_1</p> <p>A= 86,000 B= 81,800 D= 87,000 F= 5,000 H= 0,000 L= 146,000</p> 		
<p>ø86,50</p> <p>4 Cyl. Diesel 2184 cc 22,9:1 R2</p> <p><u>1997 -....</u></p> <p><i>Besta Yeni Tip Crew Cap E 2200 Van/Pick Up</i></p>	<p>18-9050010 STD 18-9050013 0.50</p>	<p>A = 47,350 B = 86,150 C = 1,600</p> <p>Segman Taşıyıcı (Ring Carrier)</p> <p>Yag Galerisi (Oil Gallery)</p> <p>Sac Plaka (Steel Support)</p>	<p>RJ30855A00 -STD RJ30855C00 -0.50</p> <p>2,000 () RN Cr1 FX 2,000 () 4,000 ()</p>	<p>ø25,0 x 68,0</p>			



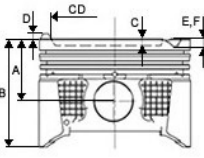



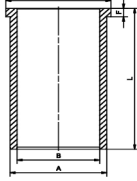

							
Motor /Engine	Ref. No. Kit 1	Ölçüler /Dimensions	Segman /Rings	Pim	Gömlek /Liner	Kit 2	Info
<p>ø86,50</p> <p>4 Sil 1984 cc 85 kW 115/116 PS 10,4:1 10,5:1 ,8 Ventile AEG APK AQY <u>1998-2008</u></p> <p><i>Besta Eski Model Crew Cap E2200 Van Pick Up</i></p>	<p>18-9050020 STD 18-9050023 0.50</p>	<p>A = 47,350 B = 86,150 C = 1,600</p> <p>Segman Taşıyıcı (Ring Carrier)</p> <p>Sac Plaka (Steel Support)</p>	<p>RJ30855A00 -STD RJ30855C00 -0.50</p> <p>2,000 () RN Cr1 FX 2,000 () 4,000 ()</p>	<p>ø25,0 x 68,0</p>	<p>G86001650K_1</p> <p>A= 89,600 B= 85,300 D= 91,500 F= 5,000 H= 0,000 L= 165,000</p> 		
<p>ø87,50</p> <p>4 Cyl. Benzin 2000cc 145 Ps HE DURATEC <u>2001....</u></p> <p><i>Mondeo 2,0 Mazda 6 2,0i 16v Atenza 2,0i 16v</i></p>	<p>18-2510310 STD 18-2510313 0.50</p>	<p>A = 28,400 B = 51,000 C = 0,350 CD= 75,400</p>	<p>RE23470000 -STD RE23470050 -0.50</p> <p>1,200 (500) Cr4B S 1,200 (501) P IFU 2,500 (700) Cr P S</p>	<p>ø21,0 x 60,0</p>			



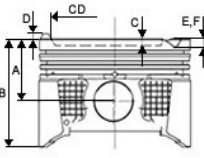





Motor /Engine	Ref. No. Kit 1	Ölçüler /Dimensions	Segman /Rings	Pim	Gömlek /Liner	Kit 2	Info
       							
ø93,00 4 Cyl. Diesel 2500 cc 79 Ps XM34 WLOHC (1997 2004) Ranger Pick Up B2500 Pick Up	18-2581980 STD 18-2581983 0.50	A = 47,800 B = 87,400 C = 1,200 Segman Taşıyıcı (Ring Carrier) Sac Plaka (Steel Support)	RE23530000 -STD RE23530050 -0.50 2,500 (500) Cr P IF 2,000 (501) Cr P IF 3,000 (604) Cr P	ø32,0 x 70,0			
 							
ø93,00 4 Cyl. Diesel 2500 cc 110 Ps XM34TD XM34TD/WL T 1998 - Ranger Pick Up Thunder, Ranger Pick Up XLT B2500 TD Ranger	18-2582990 STD 18-2582993 0.50	A = 47,850 B = 87,350 C = 2,100 Segman Taşıyıcı (Ring Carrier) Yag Galerisi (Oil Gallery) Sac Plaka (Steel Support) Yag Püskürt. Oyugu (Oil Cut-Out)	RE23530000 -STD RE23530050 -0.50 2,500 (500) Cr P IF 2,000 (501) Cr P IF 3,000 (604) Cr P	ø32,0 x 70,0	G93001620K_1 A= 96,000 B= 92,300 D= 97,500 F= 5,000 H= 0,000 L= 162,000		
  							



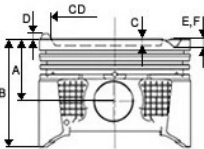



							
Motor /Engine	Ref. No. Kit 1	Ölçüler /Dimensions	Segman /Rings	Pim	Gömlek /Liner	Kit 2	Info
<p>ø93,00</p> <p>4 Cyl. Diesel 2499cc 143 PS FORD&MAZDA ORTAK (COMMON) 6M34 WL C 2006 -..... Ranger Pickup TDCI</p>	<p>18-2584020 STD 18-2584023 0.50</p>	<p>A = 51,750 B = 81,300 C = 15,100 CD= 48,500</p> <p>Segman Taşıyıcı (Ring Carrier)</p> <p>Yag Galerisi (Oil Gallery)</p>	<p>RJ30004A00 -STD RJ30004C00 -0.50</p> <p>2,000 () GN SM 1,500 () RN 2,000 () GN</p>	<p>ø34,0 x 70,0</p>	<p>G93001710K_1</p> <p>A= 96,000 B= 92,300 D= 97,500 F= 5,000 H= 0,000 L= 171,000</p> 		<p>STDconta +0,08 +0,15</p> <p>1 kertik conta +0,13 +0,25</p> <p>2 kertik conta +0,20 +0,31</p>





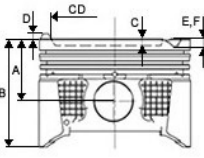
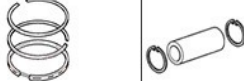

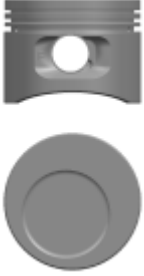
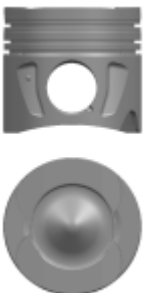

Motor /Engine	Ref. No. Kit 1	Ölçüler /Dimensions	Segman /Rings	Pim	Gömlek /Liner	Kit 2	Info
							
ø72,20 4 Cyl. Benzin 1332 cc 120 135kW 163 184 PS M 282.194 H5H 450/470/480/490 2018 - CAPTUR I (J5_H5_HF) 1.3 Tce CLIO V (B7_) 1.3 Tce GRAND SCENIC IV KADJAR (HA_HL_HC) 1.3 Tce MEGANE IV Grandtour MEGANE IV Sedan/Hatchback SCENIC IV TALISMAN LODGY (JS_) 1.3 Tce DUSTER (FM_) 1.3 Tce	18-8010020 STD 18-8010023 0.50	A = 31,550 B = 49,050 C = 5,100 E = -3,250 F = -3,850 CD= 47,300 Segman Taşıyıcı (Ring Carrier)	RE49580000 -STD RE49580050 -0.50 1,200 (500) IFU NIT S 1,500 (508) Cr P 2,000 (700) NIT S	ø20,0 x 47,0			
ø76,00 4 Cyl. Diesel 1461cc 65 KW 90 HP K9K Euro5 OM607 2010 -.... Grand Scenic III 1.5DCI 16V Megane Grandtour III 1.5dCi Megane III 1.5dCi Citane 108/109 A 160 CDI B160 CDI	18-8050840 STD 18-8050840-20 STD (-0.20 mm) 18-8050843 0.50 18-8050843-20 0.50 (-0.20 mm) 18-8050848 1.00 18-8050848-20 1.00 (-0.20 mm)	A = 41,667 B = 66,000 C = 13,500 E = -0,250 F = -0,430 CD= 47,000 Segman Taşıyıcı (Ring Carrier) Yag Püskürt. Oyugu (Oil Cut-Out)	RK80207600010 -STD RK80207600013 -0.50 RK80207600018 -1.00 2,000 (500) CKP 2,000 (501) P 2,500 (604) CrP	ø26,0 x 60,0	G79601420K_1 A= 79,600 B= 75,300 D= 81,500 F= 5,500 H= 0,000 L= 142,000		



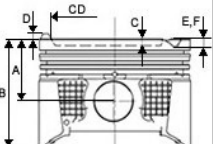



							
Motor /Engine	Ref. No. Kit 1	Ölçüler /Dimensions	Segman /Rings	Pim	Gömlek /Liner	Kit 2	Info
<p>ø76,00</p> <p>4 Cyl. Diesel 1461cc 81KW 110HP 15.5:1 K9K 837/846 EURO5 (2010>) OM607 (2013>) <u>2010>2013></u></p> <p><i>Grand Secnic III 1.5DCI16V Megane Grandtour III 1.5dCi Megane III 1.5dCi Citane 111 CLA 180 CDI GLA 180 CDI A180 CDI B180 CDI</i></p>	<p>18-8092830 STD 18-8092833 0.50 18-8092838 1.00</p>	<p>A = 41,667 B = 66,000 C = 13,500 E = -0,430 F = -0,250 CD= 47,000</p> <p>Segman Taşıyıcı (Ring Carrier)</p> <p>Yag Galerisi (Oil Gallery)</p> <p>Yag Püskürt. Oyugu (Oil Cut-Out)</p>	<p>RE49400000 -STD RE49400050 -0.50 RE49400100 -1.00</p> <p>2,000 (500) CKP 2,000 (501) P 2,500 (604) CrP</p>	<p>ø26,0 x 60,0</p>	<p>G79601420K_1</p> <p>A= 79,600 B= 75,300 D= 81,500 F= 5,500 H= 0,000 L= 142,000</p> 		
<p>ø80,00</p> <p>4 Cyl. Diesel 1598cc 96 KW 130PS R9M 402 <u>2015 -</u> Qashgai (2015 -)</p>	<p>18-8092820 STD 18-8092823 0.50</p>	<p>A = 46,000 B = 70,500 C = 12,350 E = -0,300 CD= 46,500</p> <p>Segman Taşıyıcı (Ring Carrier)</p> <p>Yag Galerisi (Oil Gallery)</p> <p>Yag Püskürt. Oyugu (Oil Cut-Out)</p>	<p>RE49510000 -STD RE49510050 -0.50</p> <p>2,000 (500) Cpk 1,750 (501) P IFU 2,000 (604) Cr P</p>	<p>ø30,0 x 60,0</p>			





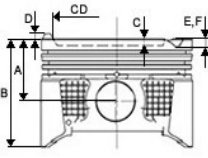
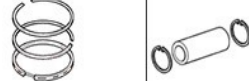



							
Motor /Engine	Ref. No. Kit 1	Ölçüler /Dimensions	Segman /Rings	Pim	Gömlek /Liner	Kit 2	Info
<p>ø80,00</p> <p>4 Cyl. Diesel 1900 cc 81/97Kw 110/132 Ps F9Q 266/759/803/804</p> <p>....-.....</p> <p>MEGANE II 1.9 dCi SCENIC II J 1.9dCi</p>	<p>18-8092950 STD</p> <p>18-8092953 0.50</p>	<p>A = 47,004</p> <p>B = 77,000</p> <p>C = 17,800</p> <p>E = -0,850</p> <p>F = -0,850</p> <p>CD= 40,000</p> <p>Segman Taşıyıcı (Ring Carrier)</p> <p>Yag Galerisi (Oil Gallery)</p> <p>Yag Püskürt. Oyugu (Oil Cut-Out)</p>	<p>RE49380000 -STD</p> <p>RE49380050 -0.50</p> <p>2,500 (500) CKP</p> <p>2,000 (501) P</p> <p>3,000 (604) Cr</p>	<p>ø28,0</p> <p>x 60,0</p>			
<p>ø80,01</p> <p>4 Cyl. Diesel 1870cc 66/81/88 Kw (95/110/120 Ps) F9Q (650/664/670 674/750/756/758 756/812/816/818 808/820/826 1999 - 2009</p> <p>Megane/Laguna II 1.9 dCi Grandtour II 1.9 dCi Scenic/Clio III 1.9 dCi Megane Grandtour 1.9 dCi Grand Scenic II 1.9 dCi Espace IV 1.9 dCi</p>	<p>18-8092930 STD</p> <p>18-8092933 0.50</p>	<p>A = 47,040</p> <p>B = 77,000</p> <p>C = 17,800</p> <p>E = -0,750</p> <p>CD= 38,000</p> <p>Segman Taşıyıcı (Ring Carrier)</p> <p>Yag Galerisi (Oil Gallery)</p> <p>Yag Püskürt. Oyugu (Oil Cut-Out)</p>	<p>RE49380000 -STD</p> <p>RE49380050 -0.50</p> <p>2,500 (500) CKP</p> <p>2,000 (501) P</p> <p>3,000 (604) Cr</p>	<p>ø28,0</p> <p>x 60,0</p>			



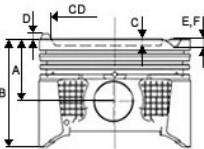





							
Motor /Engine	Ref. No. Kit 1	Ölçüler /Dimensions	Segman /Rings	Pim	Gömlek /Liner	Kit 2	Info
<p>ø82,00</p> <p>4 Cyl. Benzin 1796 cc 156 184 Ps M271 1.6 180PS <u>2007 -....</u> MERCEDES BENZ C 180 CGI-2007</p>	<p>18-5010110 STD 18-5010113 0.50</p>	<p>A = 29,900 B = 50,900 C = 1,000 E = -4,000 F = -1,000 CD= 70,000</p>	<p>RE40090000 -STD RE40090050 -0.50</p> <p>1,200 (500) NitB S 1,500 (501) P 2,500 (700) Nit S</p>	<p>ø20,0 x 56,0</p>			
<p>ø82,00</p> <p>4 Cyl. Benzin 1796cc 141 Kw (192 Ps) M271E18948 <u>2001 - 2005</u> MERCEDES BENZ C200 C230 CLK200 E200 Komp.-2001-2005</p>	<p>18-5010120 STD 18-5010123 0.50</p>	<p>A = 29,900 B = 50,900 C = 4,610 E = -1,000 F = -4,000 CD= 71,200</p> <p>Sert Anotlama (Hard Anodising)</p>	<p>RE40090000 -STD RE40090050 -0.50</p> <p>1,200 (500) NitB S 1,500 (501) P 2,500 (700) Nit S</p>	<p>ø20,0 x 56,0</p>			



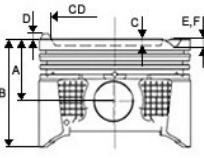



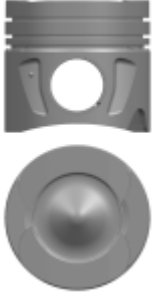

							
Motor /Engine	Ref. No. Kit 1	Ölçüler /Dimensions	Segman /Rings	Pim	Gömlek /Liner	Kit 2	Info
<p>ø82,90</p> <p>6 Cyl. Benzin, 2599 cm³ 117 kW (159 hp), 9,2:1 M103 E206 <u>1984 - 1992</u></p> <p><i>Kombi 260 Saloon 260 E S Class 260 SE 190 E</i></p>	<p>18-5010160 STD 18-5010163 0.50</p> 	<p>A = 33,000 B = 63,000 C = 1,000 CD= 53,000</p>	<p>RE40000000 -STD RE40000050 -0.50</p> <p>1,500 (500) Cr S IF 1,750 (508) P 3,000 (604) Cr P</p>	<p>ø22,0 x 52,0</p>			
<p>ø83,00</p> <p>4 Cyl. Diesel 2143 cc 150 Kw (204 Ps) 16,2: OM 651.912 <u>2007 -....</u></p> <p><i>C 250-GLK 220 CDI Blue Efficiency -GLK 250 CDI</i></p>	<p>18-5091050 STD 18-5091053 0.50</p> 	<p>A = 48,500 B = 75,500 C = 13,250 E = -1,500 F = -0,970 CD= 49,400</p> <p>Segman Taşıyıcı (Ring Carrier)</p> <p>Yag Galerisi (Oil Gallery)</p> <p>Yag Püskürt. Oyugu (Oil Cut-Out)</p>	<p>RE40210000 -STD RE40210025 -0.25 RE40210050 -0.50</p> <p>2,000 (500) Cr P IF 1,750 (501) P IFU 2,000 (604) Cr P</p>	<p>ø30,0 x 66,0</p>			



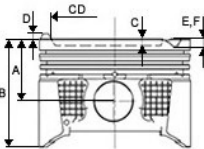





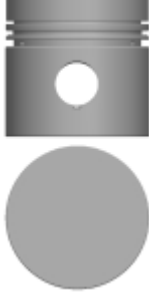
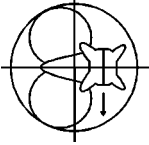

Motor /Engine	Ref. No. Kit 1	Ölçüler /Dimensions	Segman /Rings	Pim	Gömlek /Liner	Kit 2	Info
       							
ø83,00 6 Cyl. 2987 cc 155/165 Kw (211 224 Ps) 17,7:1 OM 642/910/642/920 642/921/642/930 642/932/642/940/642 950/642/960/642/961 642/970 Dizel <u>2005 - 2009</u> Piston Sol. C 350 CDI (204)	17-5092060 STD	A = 45,650 B = 71,650 C = 15,510 E = -1,430 F = -1,070 CD= 51,100 Segman Taşıyıcı (Ring Carrier) Yag Galerisi (Oil Gallery) Yag Püskürt. Oyugu (Oil Cut-Out)	RE40140000 -STD RE40140050 -0.50 2,000 (504) Cr P IF 2,000 (501) P IFU 2,000 (604) Cr P	ø33,0 x 66,0			+0,53 +0,77
ø83,00 6 Cyl. 2987 cc 155/165 Kw (211 224 Ps) 17,7:1 OM 642/910/642/920 642/921/642/930 642/932/642/940/642 950/642/960/642/961 642/970 Dizel <u>2005 - 2009</u> Piston Sağ. C 350 CDI (204)	17-5092070 STD	A = 45,650 B = 71,650 C = 15,510 E = -1,430 F = -1,070 CD= 51,100 Segman Taşıyıcı (Ring Carrier) Yag Galerisi (Oil Gallery) Yag Püskürt. Oyugu (Oil Cut-Out)	RE40140000 -STD RE40140050 -0.50 2,000 (504) Cr P IF 2,000 (501) P IFU 2,000 (604) Cr P	ø33,0 x 66,0			+0,53 +0,77

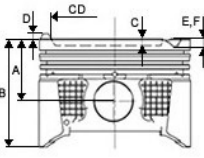





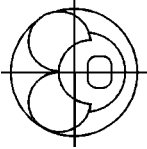

							
Motor /Engine	Ref. No. Kit 1	Ölçüler /Dimensions	Segman /Rings	Pim	Gömlek /Liner	Kit 2	Info
<p>ø83,00</p> <p>6 Cyl. 2987 cc 155/165 Kw (211 224 Ps) 17,7:1 OM 642/910/642/920 642/921/642/930 642/932/642/940/642 950/642/960/642/961 642/970 Dizel <u>2005 - 2009</u></p> <p><i>Piston Sol, CLS 320 CDI E 280 CDI E 300 Bluetec, E 320 CDI</i></p>	<p>17-5092080 STD</p>	<p>A = 45,650 B = 71,650 C = 14,650 E = -1,330 F = -1,490 CD= 43,400</p> <p>Segman Taşıyıcı (Ring Carrier)</p> <p>Yag Galerisi (Oil Gallery)</p> <p>Yag Püskürt. Oyugu (Oil Cut-Out)</p>	<p>RE40140000 -STD RE40140050 -0.50</p> <p>2,000 (504) Cr P IF 2,000 (501) P IFU 2,000 (604) Cr P</p>	<p>ø30,0 x 66,0</p>			<p>+0,53 +0,77</p>
<p>ø83,00</p> <p>6 Cyl. 2987 cc 155/165 Kw (211 224 Ps) 17,7:1 OM 642/910/642/920 642/921/642/930 642/932/642/940/642 950/642/960/642/961 642/970 Dizel <u>2005 - 2009</u></p> <p><i>Piston Sağ, CLS 320 CDI E 280 CDI E 300 Bluetec, E 320 CDI</i></p>	<p>17-5092090 STD</p>	<p>A = 45,650 B = 71,650 C = 14,650 E = -1,330 F = -1,490 CD= 43,400</p> <p>Segman Taşıyıcı (Ring Carrier)</p> <p>Yag Galerisi (Oil Gallery)</p> <p>Yag Püskürt. Oyugu (Oil Cut-Out)</p>	<p>RE40140000 -STD RE40140050 -0.50</p> <p>2,000 (504) Cr P IF 2,000 (501) P IFU 2,000 (604) Cr P</p>	<p>ø30,0 x 66,0</p>			<p>+0,53 +0,77</p>



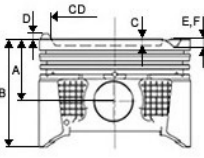



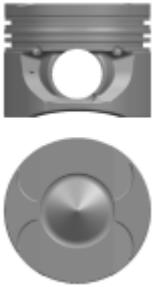

							
Motor /Engine	Ref. No. Kit 1	Ölçüler /Dimensions	Segman /Rings	Pim	Gömlek /Liner	Kit 2	Info
<p>ø83,00</p> <p>6 Cyl. Diesel 2987 cc 155 Kw 210 Ps OM 642.820 <u>2010 -</u></p> <p><i>1.2.3. Sil. GL 320 CDI GL 350 CDI ML 300 CDI ML320 CDI ML 350 CDI</i></p>	<p>17-5092100 STD</p>	<p>A = 45,650 B = 71,650 C = 14,650 E = -1,430 F = -1,070 CD= 43,400</p> <p>Segman Taşıyıcı (Ring Carrier)</p> <p>Yag Galerisi (Oil Gallery)</p> <p>Yag Püskürt. Oyugu (Oil Cut-Out)</p>	<p>RE40140000 -STD RE40140050 -0.50</p> <p>2,000 (504) Cr P IF 2,000 (501) P IFU 2,000 (604) Cr P</p>	<p>ø30,0 x 66,0</p>			
<p>ø83,00</p> <p>4 Cyl. Diesel 1991cc 80 Kw (109 Ps) 18:1 OM 640.940 941 942 A160 180 200CDI <u>2004 -</u></p> <p><i>MERCEDES BENZ Turbo Intercooler 16 v C.Rail A 180 CDI B 180 CDI</i></p>	<p>18-5092130 STD 18-5092133 0.50</p>	<p>A = 45,650 B = 71,650 C = 14,650 E = -1,180 F = -1,020 CD= 43,400</p> <p>Segman Taşıyıcı (Ring Carrier)</p> <p>Yag Galerisi (Oil Gallery)</p> <p>Yag Püskürt. Oyugu (Oil Cut-Out)</p>	<p>RE40140000 -STD RE40140050 -0.50</p> <p>2,000 (504) Cr P IF 2,000 (501) P IFU 2,000 (604) Cr P</p>	<p>ø30,0 x 66,0</p>			



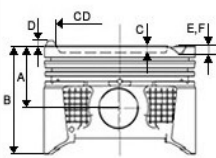





							
Motor /Engine	Ref. No. Kit 1	Ölçüler /Dimensions	Segman /Rings	Pim	Gömlek /Liner	Kit 2	Info
<p>ø83,00</p> <p>6 Cyl. Diesel 2987 cc 155 Kw 210 Ps OM 642.820 <u>2010 -</u></p> <p>4,5,6.Sil. GL 320 CDI GL 350 CDI ML 300 CDI ML320 CDI ML 350 CDI</p>	<p>17-5092200 STD</p>	<p>A = 45,650 B = 71,650 C = 14,650 E = -1,430 F = -1,070 CD= 43,400</p> <p>Segman Taşıyıcı (Ring Carrier)</p> <p>Yag Galerisi (Oil Gallery)</p> <p>Yag Püskürt. Oyugu (Oil Cut-Out)</p>	<p>RE40140000 -STD RE40140050 -0.50</p> <p>2,000 (504) Cr P IF 2,000 (501) P IFU 2,000 (604) Cr P</p>	<p>ø30,0 x 66,0</p>			
<p>ø83,00</p> <p>4 Cyl. Diesel 2143cc OM 651 Euro 5 OM 911/912/913/916 <u>2007 -....</u></p> <p>C180 CDI C200 CDI C220 CDI C250 CDI CLS 250 CDI E200 CDI E220 CDI</p>	<p>18-5094050 STD 18-5094053 0.50</p>	<p>A = 48,500 B = 75,500 C = 13,250 E = -1,500 F = -0,930 CD= 49,400</p> <p>Segman Taşıyıcı (Ring Carrier)</p> <p>Yag Galerisi (Oil Gallery)</p> <p>Burc (Bushing)</p>	<p>RE40210000 -STD RE40210025 -0.25 RE40210050 -0.50</p> <p>2,000 (500) Cr P IF 1,750 (501) P IFU 2,000 (604) Cr P</p>	<p>ø30,0 x 66,0</p>			



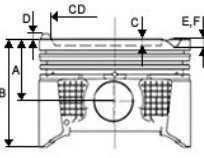





							
Motor /Engine	Ref. No. Kit 1	Ölçüler /Dimensions	Segman /Rings	Pim	Gömlek /Liner	Kit 2	Info
<p>ø87,00</p> <p>4 Cyl. Benzin 1988cc 62/70 KW 85/95PS M115.923/926/938/939 <u>1968 - 1980</u></p> <p>200 220</p>	<p>18-5010230 STD 18-5010233 0.50 18-5010238 1.00</p> 	<p>A = 52,400 B = 84,400</p> <p>Sac Plaka (Steel Support)</p>	<p>RE40110000 -STD RE40110050 -0.50 RE40110100 -1.00</p> <p>1,750 (500) Cr S IF 2,500 (508) P 4,000 (604) Cr P</p>	<p>ø26,0 x 72,0</p>			
<p>ø87,00</p> <p>4 Cyl. Diesel 1988 cc 44 Kw (60 Ps) 21:1 OM 615 910/912/914/917 941/918/930/936 939 <u>1976 - 1991</u></p> <p>Saloon 200 D</p>	<p>18-5050850 STD 18-5050853 0.50 18-5050858 1.00</p> 	<p>A = 52,900 B = 91,400 C = 9,000 E = -1,200</p> <p>Segman Taşıyıcı (Ring Carrier)</p> <p>Sac Plaka (Steel Support)</p>	<p>RE40080000 -STD RE40080050 -0.50 RE40080100 -1.00</p> <p>2,000 (500) CrB S 2,000 (501) P IF 4,000 (604) Cr P</p>	<p>ø26,0 x 72,0</p>			<p>+0,65 +1,05</p>



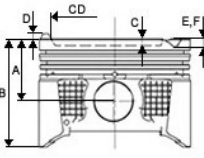





							
Motor /Engine	Ref. No. Kit 1	Ölçüler /Dimensions	Segman /Rings	Pim	Gömlek /Liner	Kit 2	Info
<p>ø87,00</p> <p>4 Cyl. Diesel 2197 cc 44 49 Kw (60 67 Ps OM 615 910/912/914/917 941/918/930/936 939 <u>1968 - 1974</u></p> <p><i>Saloon 200 D City Bus 2,0 D S 206 D S 306 D 220 D 406 409 309 U45 U52</i></p> 	<p>18-5050860 STD 18-5050863 0.50 18-5050868 1.00</p>	<p>A = 52,850 B = 91,350 C = 6,000 E = -1,000 F = -3,350 CD= 50,000</p> <p>Segman Taşıyıcı (Ring Carrier)</p>	<p>RE40070000 -STD RE40070050 -0.50 RE40070100 -1.00</p> <p>3,000 (500) Cr IF 2,000 (501) P IF 4,000 (604) Cr P</p>	<p>ø26,0 x 72,0</p>			
<p>ø87,00</p> <p>4 5 6 Cyl. Diesel 1997 cc 53 Kw (72 Ps) 22:1 OM 601 OM 602 OM 603 <u>1984 - 1994</u></p> <p><i>190 D E 200 D C 200 D 250 D 250 GD 300 D</i></p> 	<p>18-5050870 STD 18-5050873 0.50 18-5050878 1.00</p>	<p>A = 44,850 B = 74,850 C = 9,050 E = -1,050 F = -1,250</p> <p>Segman Taşıyıcı (Ring Carrier)</p> <p>Sac Plaka (Steel Support)</p>	<p>RE40160000 -STD RE40160050 -0.50 RE40160100 -1.00</p> <p>2,500 (500) Cr 2,000 (501) P IF 3,000 (604) Cr P</p>	<p>ø26,0 x 55,0</p>			<p>+0,735 +0,965</p>



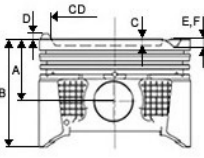





							
Motor /Engine	Ref. No. Kit 1	Ölçüler /Dimensions	Segman /Rings	Pim	Gömlek /Liner	Kit 2	Info
<p>ø87,00</p> <p>5 Cyl. Diesel 2496 cc 90 93 Kw (122 126 Ps) OM602A 2.5 D TD</p> <p><u>1988 - 1995</u></p> <p>MERCEDES BENZ 190 D 2.5 250 D Turbo E 250 TD 1988 - 1995</p>	<p>17-5095880 STD</p> <p>17-5095883 0.50</p>	<p>A = 44,850 B = 74,850 C = 9,100 E = -1,050 F = -1,250</p> <p>Segman Taşıyıcı (Ring Carrier)</p> <p>Sert Anotlama (Hard Anodising)</p> <p>Yag Galerisi (Oil Gallery)</p>	<p>RE40160000 -STD RE40160050 -0.50 RE40160100 -1.00</p> <p>2,500 (500) Cr 2,000 (501) P IF 3,000 (604) Cr P</p>	<p>ø28,0 x 70,0</p>			<p>+ 0,73 + 0,96</p>
<p>ø88,00</p> <p>4 Cyl. Diesel, 2151 cm³ 75 90 kW (102 122 hp) 611 030 1217 OM 611 DE22 LA Euro 3 OM 612 DE27LA Euro 3 OM 613</p> <p><u>1999 -....</u></p> <p>Turbo Intercooler Common Rail C 200/220/270CDI E 200/220/270CDI Sprinter 208/211/213 313/408/411/413 215/316/416/CDI V 220CDI V 220CDI Vito 108 ML270CDI CLK270 CDI E 320 CDI/S 320 CDI</p>	<p>18-5091760 STD</p> <p>18-5091760-20 STD (-0.20 mm)</p> <p>18-5091763 0.50</p> <p>18-5091763-20 0.50 (-0.20 mm)</p> <p>18-5091768 1.00</p>	<p>A = 42,300 B = 68,300 C = 13,800 E = -2,000 F = -2,100 CD= 43,500</p> <p>Segman Taşıyıcı (Ring Carrier)</p> <p>Yag Galerisi (Oil Gallery)</p> <p>Yag Püskürt. Oyugu (Oil Cut-Out)</p>	<p>RE40770000 -STD RE40770050 -0.50 RE40770100 -1.00</p> <p>2,500 (500) Cr P IF 2,000 (501) P IF 3,000 (604) Cr P</p>	<p>ø30,0 x 70,0</p>			<p>+ 0,83 + 1,06</p>



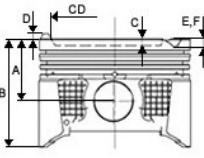





Motor /Engine	Ref. No. Kit 1	Ölçüler /Dimensions	Segman /Rings	Pim	Gömlek /Liner	Kit 2	Info
							
ø88,00 4/5/6 Cyl. Diesel, 2148 cm ³ 80 110 kW (109 150 hp) 646 030 0117 OM 646.961/951 962/963 966/OM 647.961/981 OM 648.9 1999.. Turbo Intercooler Common Rail Sprinter 213CDI/313CDI 413CDI/308/311/314 408/411/413/414/416 Vito-VIANO CDI Vito C220CDI W203/E220CDI W211 E 200CDI C 200CDI E 270CDI E 280CDI E 320CDI S 320CDI	17-5091770 STD 17-5091770-20 STD (-0.20 mm) 17-5091773 0.50 17-5091773-20 0.50 (-0.20 mm) 17-5091778 1.00 17-5091778-20 1.00 (-0.20 mm)	A = 42,300 B = 68,300 C = 14,100 E = -1,900 F = -2,100 CD= 46,000 Segman Taşıyıcı (Ring Carrier) Yag Galerisi (Oil Gallery)	RE40770000 -STD RE40770050 -0.50 RE40770100 -1.00 2,500 (500) Cr P IF 2,000 (501) P IF 3,000 (604) Cr P	ø30,0 x 70,0			+ 0,38 + 0,60
ø88,00 4 Cyl. Diesel 2151 cc 85 105 Kw OM 611 DE 22LA 1998 - 2003 MERCEDES BENZ C200/220 CDI E200/220 CDI	18-5092110 STD 18-5092113 0.50 18-5092118 1.00	A = 42,300 B = 72,300 C = 13,800 E = -1,900 F = -2,400 CD= 43,500 Segman Taşıyıcı (Ring Carrier) Yag Galerisi (Oil Gallery)	RE40770000 -STD RE40770050 -0.50 RE40770100 -1.00 2,500 (500) Cr P IF 2,000 (501) P IF 3,000 (604) Cr P	ø30,0 x 70,0			+ 0,38 + 0,62



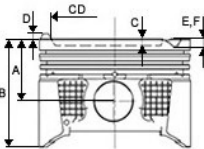





							
Motor /Engine	Ref. No. Kit 1	Ölçüler /Dimensions	Segman /Rings	Pim	Gömlek /Liner	Kit 2	Info
<p>ø88,00</p> <p>4 Cyl. Diesel 2151 cc 85 105 Kw OM 612.963 981 Euro 3 %20 DÜŞÜK KOMPRESYON <u>1998 - 2003</u> MERCEDES BENZ C270 CDI E270 CDI ML270 CDI 4X4</p>	<p>18-5092120 STD</p>	<p>A = 42,300 B = 72,300 C = 13,800 E = -1,900 F = -2,400 CD= 43,500</p> <p>Segman Taşıyıcı (Ring Carrier)</p> <p>Yag Galerisi (Oil Gallery)</p>	<p>RE40770000 -STD RE40770050 -0.50 RE40770100 -1.00</p> <p>2,500 (500) Cr P IF 2,000 (501) P IF 3,000 (604) Cr P</p>	<p>ø30,0 x 70,0</p>			<p>+ 0,38 + 0,62</p>
<p>ø88,00</p> <p>4 Cyl. Diesel 2151 cc 85 115 Kw OM 611 DE 22LA <u>1996 - 2000</u> MERCEDES BENZ C 200 CDI C 220 CDI E 200 CDI E 220 CDI</p>	<p>18-5092140 STD 18-5092143 0.50</p>	<p>A = 42,300 B = 72,300 C = 13,300 E = -1,910 F = -2,420 CD= 43,100</p> <p>Segman Taşıyıcı (Ring Carrier)</p> <p>Yag Galerisi (Oil Gallery)</p>	<p>RE40770000 -STD RE40770050 -0.50 RE40770100 -1.00</p> <p>2,500 (500) Cr P IF 2,000 (501) P IF 3,000 (604) Cr P</p>	<p>ø28,0 x 70,0</p>			<p>+ 0,38 + 0,62</p>



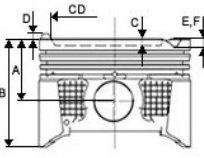



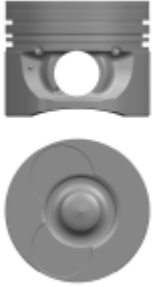

							
Motor /Engine	Ref. No. Kit 1	Ölçüler /Dimensions	Segman /Rings	Pim	Gömlek /Liner	Kit 2	Info
<p>ø88,00</p> <p>4 Cyl. Diesel 2150cc 65/80/95/110 Kw 88/109/129/150 Ps OM 646 986 C.Rail Euro 4 <u>2007 -....</u></p> <p>MERCEDES BENZ Sprinter 209CDI 211CDI 213CDI 215CDI</p>	<p>18-5094110 STD 18-5094113 0.50</p>	<p>A = 42,400 B = 72,300 C = 14,100 E = -2,030 F = -1,780 CD= 46,000</p> <p>Segman Taşıyıcı (Ring Carrier)</p> <p>Yag Galerisi (Oil Gallery)</p> <p>Yag Püskürt. Oyugu (Oil Cut-Out)</p>	<p>RE40580000 -STD RE40580050 -0.50</p> <p>2,500 (xxx) CKS 2,000 (xxx) CR 2,000 (xxx) CR</p>	<p>ø30,0 x 70,0</p>			<p>+0,38 +0,62</p>
<p>ø88,50</p> <p>6 Cyl. Benzin 2962 cc 126 140 Kw M103 E30.981 982 983 985 <u>1985 - 1992</u></p> <p>MERCEDES Injection Catal.Conv.300 E 300 GE</p>	<p>17-5010130 STD 17-5010133 0.50 17-5010138 1.00</p>	<p>A = 33,000 B = 63,000 C = 2,700 E = -0,820 F = -2,020</p> <p>Sac Plaka (Steel Support)</p>	<p>RE40190000 -STD RE40190050 -0.50</p> <p>1,500 (500) Nit S IF 1,750 (508) P 3,000 (604) Cr P</p>	<p>ø22,0 x 52,0</p>			



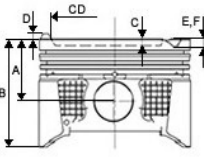





							
Motor /Engine	Ref. No. Kit 1	Ölçüler /Dimensions	Segman /Rings	Pim	Gömlek /Liner	Kit 2	Info
<p>ø89,00</p> <p>4 Cyl. Benzin 1997 cc 80 87 Kw M102 E20.962 963 965 <u>1984 - 1993</u></p> <p>MERCEDES BENZ 190E 200E 200GE 1984 - 1993</p>	<p>18-5010140 STD 18-5010143 0.50 18-5010148 1.00</p>	<p>A = 42,380 B = 74,700 D = 3,850 E = -2,530</p> <p>Sac Plaka (Steel Support)</p>	<p>RE40200000 -STD RE40200050 -0.50 RE40200100 -1.00</p> <p>1,750 (500) Cr S IF 2,000 (508) P 3,500 (604) Cr P</p>	<p>ø22,0 x 56,0</p>			
<p>ø89,00</p> <p>4 Cyl. Benzin 1997cc 87/63/72/74 KW 118/86/98/100PS M102E20.962 1984 > M102V20.938 1983 > M102V20.939 1983 > <u>(1983/1984) ></u></p> <p>190 E 200 E 190 200</p>	<p>18-5010170 STD 18-5010173 0.50 18-5010178 1.00</p>	<p>A = 43,200 B = 79,700 C = 2,000</p> <p>Sac Plaka (Steel Support)</p>	<p>RE40200000 -STD RE40200050 -0.50 RE40200100 -1.00</p> <p>1,750 (500) Cr S IF 2,000 (508) P 3,500 (604) Cr P</p>	<p>ø22,0 x 56,0</p>			

							
Motor /Engine	Ref. No. Kit 1	Ölçüler /Dimensions	Segman /Rings	Pim	Gömlek /Liner	Kit 2	Info
<p>ø89,00</p> <p>4 Cyl. Benzin 1997 cc 66 80 Kw M102 V20 920/921/924/964 M102 E20 961/962/963/964 <u>1984 - 1993</u></p> <p>190 2,0 200 200 E 200 GE</p>	<p>18-5010180 STD 18-5010183 0.50 18-5010188 1.00</p>	<p>A = 43,200 B = 79,700 E = -2,240 F = -1,720</p> <p>Sac Plaka (Steel Support)</p>	<p>RE40200000 -STD RE40200050 -0.50 RE40200100 -1.00</p> <p>1,750 (500) Cr S IF 2,000 (508) P 3,500 (604) Cr P</p>	<p>ø22,0 x 56,0</p>			
<p>ø89,00</p> <p>4 Cyl. Benzin 1997 cc 66 80 Kw M102 V20.920/921/961 M102 E20 961/962/963/964 <u>1980-1985</u></p> <p>190 E 2,0 190 2,0 200</p>	<p>18-5010190 STD 18-5010193 0.50 18-5010198 1.00</p>	<p>A = 43,200 B = 83,200 E = -1,000 F = -2,300 CD= 51,000</p> <p>Sac Plaka (Steel Support)</p>	<p>RE40200000 -STD RE40200050 -0.50 RE40200100 -1.00</p> <p>1,750 (500) Cr S IF 2,000 (508) P 3,500 (604) Cr P</p>	<p>ø24,0 x 62,0</p>			

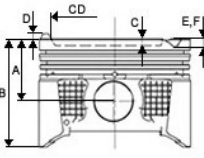







							
Motor /Engine	Ref. No. Kit 1	Ölçüler /Dimensions	Segman /Rings	Pim	Gömlek /Liner	Kit 2	Info
<p>ø89,00</p> <p>4 Cyl. Benzin 1997cc 63/74 KW 86/100PS M102V20.938 M102V20.939 <u>1982 - 1984</u></p> <p>190 200</p>	<p>18-5010350 STD 18-5010353 0.50 18-5010358 1.00</p>	<p>A = 43,200 B = 83,200 C = 2,050 E = -0,550 F = -2,050</p> <p>Sac Plaka (Steel Support)</p>	<p>RE40200000 -STD RE40200050 -0.50 RE40200100 -1.00</p> <p>1,750 (500) Cr S IF 2,000 (508) P 3,500 (604) Cr P</p>	<p>ø24,0 x 62,0</p>			
<p>ø89,00</p> <p>4 Cyl. 5 Diesel, 2299 cm³ 58 60 kW (79 82 hp) 22:2 OM 601 OM 602 OM 661 OM662 900/940 943 970 <u>1988 - 2000</u></p> <p>T 1 BOX T 1 BUS Vito Box Vito Bus Sprinter G Class 290 108D Vito 110D Vito 207D 208D Sprinter 307D 308D 407D 408D 507D 508D</p>	<p>18-5050930 STD 18-5050933 0.50 18-5050938 1.00</p> 	<p>A = 44,650 B = 74,650 C = 9,030 E = -1,050 F = -1,250</p> <p>Segman Taşıyıcı (Ring Carrier)</p> <p>Sac Plaka (Steel Support)</p> <p>Yag Püskürt. Oyugu (Oil Cut-Out)</p>	<p>RE40220000 -STD RE40220050 -0.50 RE40220070 -0.70 RE40220100 -1.00</p> <p>2,500 (500) Cr IF 2,000 (508) P 3,000 (604) Cr P</p>	<p>ø26,0 x 62,0</p>			<p>1,80 mm conta +0,84 +1,06</p> <p>2,00 mm conta +1,03 +1,06</p>



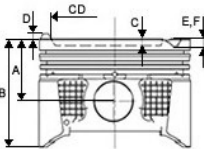





							
Motor /Engine	Ref. No. Kit 1	Ölçüler /Dimensions	Segman /Rings	Pim	Gömlek /Liner	Kit 2	Info
<p>ø89,00</p> <p>4 6Cyl. Diesel 2299 cc 72 Kw (98 Ps) 22:1 OM 601D 23A.970</p> <p><u>1996 - 1999</u></p> <p>MERCEDES BENZ Viano 110D Vito 108D 110D 1996 - 1999</p>	<p>18-5089440 STD</p> <p>18-5089440-20 STD (-0.20 mm)</p> <p>18-5089443 0.50</p>	<p>A = 44,650 C = 9,060 E = -1,050 F = -1,250</p> <p>Segman Taşıyıcı (Ring Carrier)</p> <p>Sert Anotlama (Hard Anodising)</p> <p>Yag Galerisi (Oil Gallery)</p>	<p>RE40220000 -STD RE40220050 -0.50 RE40220070 -0.70 RE40220100 -1.00</p> <p>2,500 (500) Cr IF 2,000 (508) P 3,000 (604) Cr P</p>	<p>ø28,0 x 70,0</p>			<p>1,74 mm conta + 0,83 + 1,06</p> <p>1,97 mm conta + 1,03 + 1,26</p>
<p>ø89,00</p> <p>5 Cyl. Diesel, 2874 cm³ 90 kW (122 hp) 602 030 0517 OM 602DE 29LA 980/982/983/984/985</p> <p><u>1995 -....</u></p> <p>Dizel 2874 cc 90-95 Kw (122-129 Ps) 19.5:1 Turbo 290GD E290TD Sprinter 212D Sprinter 312D Sprinter 412D 1994-2000</p>	<p>17-5091750 STD</p> <p>17-5091750-20 STD (-0.20 mm)</p> <p>17-5091753 0.50</p> <p>17-5091753-20 0.50 (-0.20 mm)</p> <p>17-5091758 1.00</p> <p>17-5091758-20 1.00 (-0.20 mm)</p>	<p>A = 44,750 B = 71,250 C = 16,730 E = -0,300 F = -0,600 CD= 42,000</p> <p>Segman Taşıyıcı (Ring Carrier)</p> <p>Yag Galerisi (Oil Gallery)</p>	<p>RE40220000 -STD RE40220050 -0.50 RE40220070 -0.70 RE40220100 -1.00</p> <p>2,500 (500) Cr IF 2,000 (508) P 3,000 (604) Cr P</p>	<p>ø28,0 x 70,0</p>			



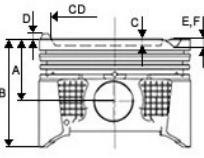





							
Motor /Engine	Ref. No. Kit 1	Ölçüler /Dimensions	Segman /Rings	Pim	Gömlek /Liner	Kit 2	Info
<p>ø89,00</p> <p>4 Cyl. Diesel 2155 cc 70 Kw (95 Ps) OM 604 D22 910 912 915 917 <u>1993 -....</u></p> <p>MERCEDES BENZ C220 D E220 D (1993 -)</p>	<p>18-5092150 STD 18-5092153 0.50</p>	<p>A = 43,550 B = 73,550 C = 4,550 E = -2,350</p> <p>Segman Taşıyıcı (Ring Carrier)</p> <p>Yag Galerisi (Oil Gallery)</p>	<p>RE40220000 -STD RE40220050 -0.50 RE40220070 -0.70 RE40220100 -1.00</p> <p>2,500 (500) Cr IF 2,000 (508) P 3,000 (604) Cr P</p>	<p>ø26,0 x 55,0</p>			<p>+ 0,73 + 0,97</p>
<p>ø89,90</p> <p>4 Cyl. Benzin, 2199 cm³ 110 kW (150 hp) M111 E <u>1993 -....</u></p> <p>C 220 E 220</p>	<p>18-5010200 STD 18-5010203 0.50</p>	<p>A = 32,900 B = 59,900 C = 1,500 E = -1,990 F = -2,980 CD= 70,000</p>	<p>RE40660000 -STD RE40660050 -0.50 RE40660100 -1.00</p> <p>1,500 (500) NiT S IF 1,750 (508) P 3,000 (700) NiT S</p>	<p>ø22,0 x 56,0</p>			

							
Motor /Engine	Ref. No. Kit 1	Ölçüler /Dimensions	Segman /Rings	Pim	Gömlek /Liner	Kit 2	Info
<p>ø89,90</p> <p>6 Cyl. Benzin 3199 cc 155 170 Kw M104 E32 980/981/990/991 992/994/995/996 <u>1991 - 1998</u></p> <p>300 SE 320 SL S 320 E 320 G 320</p>	<p>18-5010210 STD 18-5010213 0.50 18-5010218 1.00</p>	<p>A = 31,120 B = 56,100 C = 1,200 CD= 74,400</p>	<p>RE40660000 -STD RE40660050 -0.50 RE40660100 -1.00</p> <p>1,500 (500) NİT S IF 1,750 (508) P 3,000 (700) NİT S</p>	<p>ø22,0 x 56,0</p>			
<p>ø89,90</p> <p>4 Cyl. Benzin 1996 cc 95 100 Kw M111 E20 940/941/942 <u>1993 -....</u></p> <p>200 E 200 CE 300 TE E200 C200</p>	<p>18-5010220 STD 18-5010223 0.50 18-5010228 1.00</p>	<p>A = 31,650 B = 55,150 E = -1,400 F = -1,900</p>	<p>RE40660000 -STD RE40660050 -0.50 RE40660100 -1.00</p> <p>1,500 (500) NİT S IF 1,750 (508) P 3,000 (700) NİT S</p>	<p>ø22,0 x 56,0</p>			

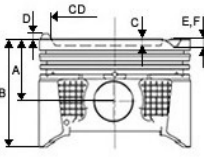











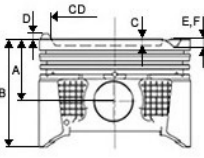





							
Motor /Engine	Ref. No. Kit 1	Ölçüler /Dimensions	Segman /Rings	Pim	Gömlek /Liner	Kit 2	Info
<p>ø89,90</p> <p>6 Cyl. Benzin 2799cc 150 KW 240 PS M112.915/917/912 914/916/913</p> <p><u>1995 -</u></p> <p>C240 CLK240 E280</p>	<p>17-5010320 STD 17-5010323 0.50</p>	<p>A = 33,700 B = 58,700 C = 0,600 E = -2,060 CD= 1,400</p> <p>Sert Anotlama (Hard Anodising)</p>	<p>RE40660000 -STD RE40660050 -0.50 RE40660100 -1.00</p> <p>1,500 (500) NiT S IF 1,750 (508) P 3,000 (700) NiT S</p>	<p>ø22,0 x 52,0</p>			
<p>ø90,90</p> <p>4 Cyl. Benzin 2295cc 103 110 Kw 140 150PS M111.970</p> <p><u>1996 -</u></p> <p>MERCEDES BENZ C230 E230 ML230 1996 -</p>	<p>18-5010150 STD 18-5010153 0.50</p>	<p>A = 30,000 B = 55,000 D = 2,900 E = -1,000 CD= 88,000</p>	<p>RE40670000 -STD RE40670050 -0.50</p> <p>1,500 (500) NiT S IF 1,750 (508) P 3,000 (700) NiT S</p>	<p>ø22,0 x 56,0</p>			

							
Motor /Engine	Ref. No. Kit 1	Ölçüler /Dimensions	Segman /Rings	Pim	Gömlek /Liner	Kit 2	Info
<p>ø92,90</p> <p>V6/8 Benzin, 3498/4663 cm³ 190/215250 kW (258/292/340 PS) 10:1/12,2:1,24Ventile 10,7:1,32Ventile M 272.960/961,964/967 970 972/975,977/980 988/991 Euro 4 M 273.922/924 2005 -</p> <p>C 350 CLC 350 CLS 350 E 350 E 350 T GLK 350 ML 350 R 350 S 350 SL 350 SPRINTER 3 SPRINTER 224/424/524 VITO 126 3.5 VIANO 3.5 GL 450 S 450</p>	<p>17-5010330 STD 17-5010333 0.50</p>	<p>A = 30,430 B = 50,830 E = -1,550</p>		<p>ø20,0 x 48,0</p>			
<p>ø93,75</p> <p>4 Cyl. Benzin 2307cc 66/78 KW 90/102PS 90:1 M115/970/971/972 973/974//952/955 1973 - 1982</p> <p>O 309 230 230G</p>	<p>18-5010240 STD 18-5010242 0.40 18-5010247 0.80</p>	<p>A = 51,800 B = 82,000</p> <p>Sac Plaka (Steel Support)</p>	<p>RE40280000 -STD RE40280040 -0.40 RE40280080 -0.80</p> <p>1,750 (500) CR P IF 2,500 (508) P 4,000 (604) CR P</p>	<p>ø26,0 x 73,0</p>			

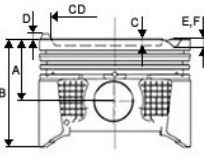







							
Motor /Engine	Ref. No. Kit 1	Ölçüler /Dimensions	Segman /Rings	Pim	Gömlek /Liner	Kit 2	Info
<p>ø95,50</p> <p>4 Cyl. Benzin 2307 cc 66 Kw (90 Ps) 9 M102 V20.920/921/961 M102 E20.961/962/963/964 <u>1973 - 1982</u></p> <p>190 E 230E Injection Catal.Conv.</p>	<p>18-5010300 STD 18-5010303 0.50 18-5010308 1.00</p>	<p>A = 43,200 B = 78,700 C = 1,850 E = -3,460 F = -1,750 CD= 70,000</p> <p>Sac Plaka (Steel Support)</p>	<p>RE40290000 -STD RE40290050 -0.50 RE40290100 -1.00</p> <p>1,750 (500) CR IF 2,000 (508) P 3,500 (604) CR P</p>	<p>ø22,0 x 56,0</p>			
<p>ø95,50</p> <p>4 Cyl. Benzin 2299 cc 92 Kw (125 PS) M102 V20.920/921/961 M102 E20.961/962/963/964 <u>1980 - 1983</u></p> <p>230 GE 230 E</p>	<p>18-5010310 STD 18-5010313 0.50 18-5010318 1.00</p>	<p>A = 43,200 B = 83,200 C = 1,850 E = -1,500 F = -2,300 CD= 70,000</p> <p>Sac Plaka (Steel Support)</p>	<p>RE40290000 -STD RE40290050 -0.50 RE40290100 -1.00</p> <p>1,750 (500) CR IF 2,000 (508) P 3,500 (604) CR P</p>	<p>ø24,0 x 62,0</p>			<p>+0,50 +0,90</p>



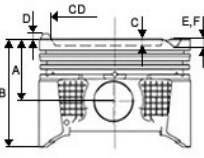









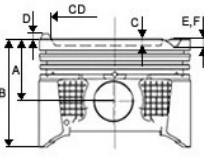









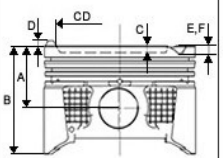

							
Motor /Engine	Ref. No. Kit 1	Ölçüler /Dimensions	Segman /Rings	Pim	Gömlek /Liner	Kit 2	Info
<p>ø130,00</p> <p>6/8 Cyl. Diesel 11940/6 15920/8 cc 313/428/354/394 476/530/571Ps 17,25:1Turbo,Intercoole4 Cyl.v OM 501 LA/OM 521 LA OM 542 LA 230/315/260/290 350/420Kw 1996 -</p> <p>1831 1835 1839 Actros 1840/1843/2531 2535/2539/2543/2548/2553</p>	<p>17-5092500 STD</p>	<p>A = 78,550 B = 119,550 C = 18,200 CD= 88,500</p> <p>Segman Taşıyıcı (Ring Carrier)</p> <p>Yag Galerisi (Oil Gallery)</p>					
<p>ø130,00</p> <p>6/8 Cyl.Diesel 320/290/260 KW 354/394/435 PS Euro 2/3 OM 542.948/320/435 OM 541.925/645/943 0000 -.</p> <p>0 350 17 RHD 0 350 0 580-15 RH</p>	<p>17-5092900 STD</p>	<p>A = 78,550 B = 123,550 C = 16,250 CD= 92,900</p> <p>Segman Taşıyıcı (Ring Carrier)</p> <p>Yag Galerisi (Oil Gallery)</p>	<p>RE40560000 -STD</p> <p>3,000 (505) CR S IF 3,000 (501) CR IWU 4,000 (604) CR</p>	<p>ø52,0 x 103,0</p>			







							
Motor /Engine	Ref. No. Kit 1	Ölçüler /Dimensions	Segman /Rings	Pim	Gömlek /Liner	Kit 2	Info
<p>ø77,00</p> <p>4 Cyl.Benzin 1598 cc 75/88/90/147 102/120/122/200 PS BMW N 13 B16A MINI N18 B 16A 5FU(EP6CDTX/EP6DTX) 5FW(EP6) <u>2010 -....</u></p> <p>BMW 116i MINI COOPER S 1.6i 16V PEUGEOT 77 MM</p>	<p>18-5510310 STD 18-5510310-30 STD 18-5510313 0.50 18-5510313-30 0.50</p>	<p>A = 28,500 B = 51,200 C = 3,500 D = 2,700 E = -3,300 F = -3,400 CD= 34,700</p> <p>Sert Anotlama (Hard Anodising)</p>	<p>RE15260000 -STD RE15260000_NPR -STD x 48,0 RE15260050 -0.50 RE15260050_NPR -0.50</p> <p>1,200 (500) Cr S IF 1,500 (508) P 2,000 (700) Cr P S</p>	<p>ø20,0 x 48,0</p>			
<p>ø77,00</p> <p>4 Cyl.Benzin 1598 cc EP6 EP6C <u>2010 -....</u></p> <p>3008 16i 16V 5008 1.6i 2 207 1.6 16V 308 1.6 16V</p>	<p>18-5510320 STD 18-5510323 0.50</p>	<p>A = 27,500 B = 47,500 C = 2,000 E = -5,700 F = -3,800 CD= 56,600</p>	<p>RE15260000 -STD RE15260000_NPR -STD x 43,0 RE15260050 -0.50 RE15260050_NPR -0.50</p> <p>1,200 (500) Cr S IF 1,500 (508) P 2,000 (700) Cr P S</p>	<p>ø18,0 x 43,0</p>			





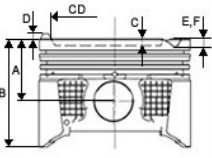
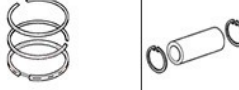



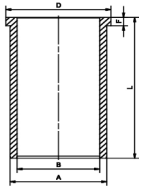
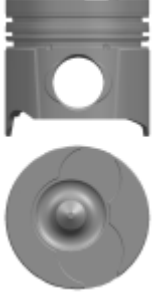

							
Motor /Engine	Ref. No. Kit 1	Ölçüler /Dimensions	Segman /Rings	Pim	Gömlek /Liner	Kit 2	Info
<p>ø77,00</p> <p>4 Cyl. Benzin 1598 cc (175PS) 115 156 PS 2010 ÖNCESİ EP6D1.6L R55 R56 R57 <u>2007-2010</u></p> <p>MINI COOPER 208 3008 308 508</p>	<p>18-5510330 STD 18-5510330-30 STD 18-5510333 0.50 18-5510333-30 0.50</p>	<p>A = 28,500 B = 51,200 C = 3,500 D = 2,700 E = -3,300 F = -3,400 CD= 34,700</p> <p>Sert Anotlama (Hard Anodising)</p>	<p>RE15260000 -STD RE15260000_NPR -STD x 48,0 RE15260050 -0.50 RE15260050_NPR -0.50</p> <p>1,200 (500) Cr S IF 1,500 (508) P 2,000 (700) Cr P S</p>	<p>ø20,0 x 48,0</p>			
<p>ø77,00</p> <p>4 Cyl. Benzin 1598 cc</p> <p>GÜÇLENDİRİLMİŞ S R53*/R52/JCW GP 1.6 I4 <u>2000 - 2008</u></p> <p>MINI COOPER S R53 CABRIO R52 MINI COOPER S JCW/CHALLENGE</p>	<p>18-5510360 STD 18-5510363 0.50</p>	<p>A = 26,300 B = 47,000 C = 0,600 CD= 56,500</p> <p>Segman Taşıyıcı (Ring Carrier)</p> <p>Sert Anotlama (Hard Anodising)</p>	<p>RE41010000 -STD RE41010000_AS -STD x 47,5 RE41010050 -0.50 RE41010050_AS -0.50</p> <p>1,200 (500) CrSIF 1,200 (508) P 2,500 (700) CrPS</p>	<p>ø21,0 x 47,5</p>			

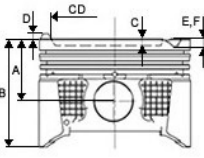







							
Motor /Engine	Ref. No. Kit 1	Ölçüler /Dimensions	Segman /Rings	Pim	Gömlek /Liner	Kit 2	Info
<p>ø77,00</p> <p>4 Cyl. Diesel 1598 cc 199/184/199KW 1.6 THP 16v 270 EP6CDTR BMW6EP6FADTR ADTR EU62V EP6FDTR</p> <p>.....-</p> <p>EP6FADTR ADTR EU62V EP6FDTR</p> 	<p>18-5510390 STD 18-5510393 0.50</p>	<p>A = 28,500 B = 48,500 C = 3,000 E = -3,400 F = -3,400</p> <p>Sert Anotlama (Hard Anodising)</p>	<p>RE15260000 -STD RE15260000_NPR -STD x 48,0 RE15260050 -0.50 RE15260050_NPR -0.50</p> <p>1,200 (500) Cr S IF 1,500 (508) P 2,000 (700) Cr P S</p>	<p>ø20,0</p>			
<p>ø77,00</p> <p>4 Cyl. Benzin 1397 cc 50/70 kW 75/95 PS EP3 N12B14A</p> <p>.....-</p> <p>207 WA/WC 1.4 16V 207 SW (WK) 1.4 16V 308 4A/4C 1.4 16V</p> 	<p>18-7510280 STD 18-7510283 0.50</p>	<p>A = 27,600 B = 47,500 D = 3,100</p>	<p>RE15260000 -STD RE15260000_NPR -STD x 43,0 RE15260050 -0.50 RE15260050_NPR -0.50</p> <p>1,200 (500) Cr S IF 1,500 (508) P 2,000 (700) Cr P S</p>	<p>ø18,0</p>			



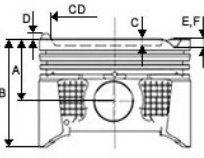





Motor /Engine	Ref. No. Kit 1	Ölçüler /Dimensions	Segman /Rings	Pim	Gömlek /Liner	Kit 2	Info
       							
ø78,00 4 Cyl. Diesel 1568 cc 70/66/85 KW 90/95/116 HP N47 D16A/N N47C16A <u>2012 -....</u> 114d 116d Cooper 1.6D Cooper One 1.6D Countryman	18-5592100 STD 18-5592103 0.50	A = 40,000 B = 62,500 C = 13,350 CD= 47,100 Segman Taşıyıcı (Ring Carrier) Yag Galerisi (Oil Gallery) Sac Plaka (Steel Support)	RE15480000 -STD RE15480050 -0.50 1,750 (500) Cr P IF 1,750 (501) P IFU 2,000 (604) Nit S	ø26,0 x 56,0			
 							
ø82,00 3/4 Cyl. Benzin 1499/1597/1998 cc 100/115/120/125 135/150/170/185 200/215kW 109..292HP B38 A15 A/C B48 A20 A/C B48 B16/20 A ZINOPRO B38 A15 C xDrive sDrive Mild/E Plug in Hybrid <u>2015 - 2021</u> F20/F21/F23/F33/F83 F22/F87/F32/F82/F36 F90/F97/F98 G20/G80/G28/G21/G81 G01/G02/G22/G31 Cabrio Coupe Torring/Van Gran Coupe/X3/X4	17-5510300 STD 17-5510303 0.50	A = 33,300 B = 52,700 C = 2,000 E = -4,800 F = -5,100 CD= 56,000 Sert Anotlama (Hard Anodising)	RE15360000 -STD RE15360050 -0.50 1,200 (500) Nit S 1,500 (508) P 2,000 (700) Nit S	ø21,0 x 51,0			
 							



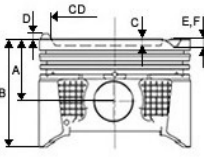





Motor /Engine	Ref. No. Kit 1	Ölçüler /Dimensions	Segman /Rings	Pim	Gömlek /Liner	Kit 2	Info
							
ø72,20 4 Cyl. Benzin 1332 cc 120 135kW 163 184 PS M 282.194 H5H 450/470/480/490 2018 - CAPTUR I (J5_H5_HF) 1.3 Tce CLIO V (B7_) 1.3 Tce GRAND SCENIC IV KADJAR (HA_HL_HC) 1.3 Tce MEGANE IV Grandtour MEGANE IV Sedan/Hatchback SCENIC IV TALISMAN LODGY (JS_) 1.3 Tce DUSTER (FM_) 1.3 Tce	18-8010020 STD 18-8010023 0.50	A = 31,550 B = 49,050 C = 5,100 E = -3,250 F = -3,850 CD= 47,300 Segman Taşıyıcı (Ring Carrier)	RE49580000 -STD RE49580050 -0.50 1,200 (500) IFU NIT S 1,500 (508) Cr P 2,000 (700) NIT S	ø20,0 x 47,0			
ø80,00 4 Cyl. Diesel 1870 cc 74 Kw (100Ps)18.3: Turbo, Intercooler F9Q. Turbo Intercooler 2000 -... Kangoo 1.9 Tdi Megane 1.9 Tdi Laguna 1.9 Tdi Scenic 1.9 Tdi Traffic 1.9 Tdi Carama 1.9 GDI Vivaro 1,9 CDTI 8 v	18-8050940 STD 18-8050943 0.50	A = 47,060 B = 77,000 C = 17,800 E = -0,750 CD= 38,000 Segman Taşıyıcı (Ring Carrier) Yag Püskürt. Oyugu (Oil Cut-Out)	RE49380000 -STD RE49380050 -0.50 2,500 (500) CKP 2,000 (501) P 3,000 (604) Cr	ø28,0 x 60,0	G80001550K_1 A= 83,000 B= 79,300 D= 85,000 F= 5,000 H= 0,000 L= 155,000 		+0,60 +0,80
							

							
Motor /Engine	Ref. No. Kit 1	Ölçüler /Dimensions	Segman /Rings	Pim	Gömlek /Liner	Kit 2	Info
<p>ø86,00</p> <p>4 Cyl. Diesel 2422 cc 113kW 154 PS 4N15 Euro VI <u>2015 - ...</u> L200</p>	<p>18-1592090 STD 18-1592093 0.50</p>	<p>A = 47,800 B = 71,500 C = 16,550 E = -1,600 F = -2,500 CD= 50,400</p> <p>Segman Taşıyıcı (Ring Carrier)</p> <p>Sert Anotlama (Hard Anodising)</p> <p>Yag Galerisi (Oil Gallery)</p>		<p>ø32,0 x 70,0</p>			
<p>ø91,10</p> <p>4 Cyl. Diesel 2477 cc 54 Kw (72 Ps) 4D56 (YENİ TİP) <u>1998 -....</u> L 300 Yeni Tip</p>	<p>18-1550060 STD 18-1550060-20 STD (-0.20 mm) 18-1550063 0.50 18-1550063-20 0.50 (-0.20 mm)</p>	<p>A = 48,700 B = 88,700 C = 0,200</p> <p>Sac Plaka (Steel Support)</p>	<p>RJ20215A00 -STD RJ20215C00 -0.50</p> <p>2,500 () RN FX 2,000 () RN 4,000 ()</p>	<p>ø29,0 x 75,0</p>			

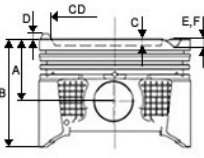







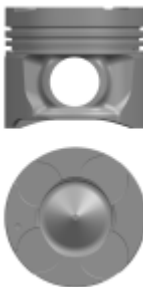

							
Motor /Engine	Ref. No. Kit 1	Ölçüler /Dimensions	Segman /Rings	Pim	Gömlek /Liner	Kit 2	Info
<p>ø91,10</p> <p>4 Cyl. Diesel 2477 cc 54 Kw (72 Ps) 21:1 4D55T <u>1986 - 2000</u></p> <p>Colt L300 Pajero Montero CanterGlant A 167 Glant Sapporo</p>	<p>18-1551220 STD 18-1551223 0.50</p>	<p>A = 48,700 B = 88,700 C = 3,200 E = -2,400 F = -2,700</p> <p>Sac Plaka (Steel Support)</p>	<p>RJ20215A00 -STD RJ20215C00 -0.50</p> <p>2,500 () RN FX 2,000 () RN 4,000 ()</p>	<p>ø29,0 x 75,0</p>			
<p>ø91,10</p> <p>4 Cyl. Diesel 2477 cc 85/100Kw 115/136/167 Ps 4D56 TDI Euro 5 C.Rail <u>2006 -.....</u></p> <p>DI-D L200</p>	<p>17-1591230 STD 17-1591233 0.50</p>	<p>A = 48,250 B = 78,250 C = 18,900 E = -2,000 F = -2,500 CD= 44,000</p> <p>Segman Taşıyıcı (Ring Carrier)</p> <p>Sert Anotlama (Hard Anodising)</p> <p>Yag Galerisi (Oil Gallery)</p>	<p>RJ20503A00 -STD RJ20503C00 -0.50</p> <p>2,500 () RN FX 2,000 () RN 4,000 ()</p>	<p>ø32,0 x 75,0</p>			

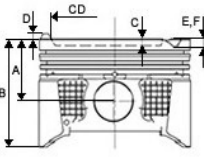





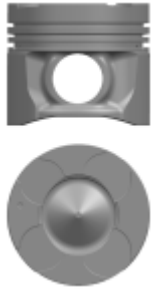

							
Motor /Engine	Ref. No. Kit 1	Ölçüler /Dimensions	Segman /Rings	Pim	Gömlek /Liner	Kit 2	Info
<p>ø91,10</p> <p>4 Cyl. Diesel 2477 cc 85/100Kw 115/136/167 Ps 4D56 TDI Euro 5 C.Rail <u>2006 -.....</u></p> <p><i>DI-D</i> <i>L200</i></p>	<p>17-1591240 STD 17-1591243 0.50</p>	<p>A = 48,250 B = 78,250 C = 18,900 E = -2,000 F = -2,500 CD= 44,000</p> <p>Segman Taşıyıcı (Ring Carrier)</p> <p>Sert Anotlama (Hard Anodising)</p> <p>Yag Galerisi (Oil Gallery)</p>	<p>RJ20503A00 -STD RJ20503C00 -0.50</p> <p>2,500 () RN FX 2,000 () RN 4,000 ()</p>	<p>ø32,0 x 75,0</p>			
<p>ø91,10</p> <p>4 Cyl. Diesel 2477 cc 62/110 Kw (84/150 Hp) 4D56T <u>1988 - 2006</u></p> <p><i>L200 MAGNUM</i></p>	<p>17-1592250 STD 17-1592253 0.50</p>	<p>A = 48,700 B = 78,700 C = 1,400</p> <p>Segman Taşıyıcı (Ring Carrier)</p> <p>Sert Anotlama (Hard Anodising)</p> <p>Yag Galerisi (Oil Gallery)</p>	<p>RJ20503A00 -STD RJ20503C00 -0.50</p> <p>2,500 () RN FX 2,000 () RN 4,000 ()</p>	<p>ø32,0 x 75,0</p>			



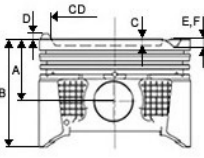





							
Motor /Engine	Ref. No. Kit 1	Ölçüler /Dimensions	Segman /Rings	Pim	Gömlek /Liner	Kit 2	Info
<p>ø91,10</p> <p>4 Cyl. Diesel 2477 cc 62/110 Kw (84/150 Hp) 4D56T <u>1988 - 2006</u> L200 MAGNUM</p>	<p>17-1592260 STD 17-1592263 0.50</p>	<p>A = 48,700 B = 78,700 C = 1,400</p> <p>Segman Taşıyıcı (Ring Carrier)</p> <p>Sert Anotlama (Hard Anodising)</p> <p>Yag Galerisi (Oil Gallery)</p>	<p>RJ20503A00 -STD RJ20503C00 -0.50</p> <p>2,500 () RN FX 2,000 () RN 4,000 ()</p>	<p>ø32,0 x 75,0</p>			
<p>ø91,10</p> <p>4 Cyl. Diesel 136HP 4D56 TDI EURO V <u>2014 -</u> L200</p>	<p>17-1592270 STD 17-1592273 0.50</p>	<p>A = 48,150 B = 78,150 C = 16,750 E = -2,000 F = -2,500 CD= 46,900</p> <p>Segman Taşıyıcı (Ring Carrier)</p> <p>Sert Anotlama (Hard Anodising)</p> <p>Yag Galerisi (Oil Gallery)</p>	<p>RJ20083A00 -STD RJ20083C00 -0.50</p> <p>2,500 () CrI SM 1,980 () RN CrI 3,000 () GN</p>	<p>ø32,0 x 75,0</p>			



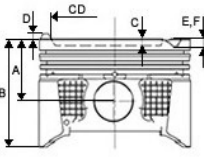









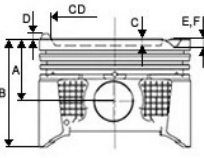





							
Motor /Engine	Ref. No. Kit 1	Ölçüler /Dimensions	Segman /Rings	Pim	Gömlek /Liner	Kit 2	Info
<p>ø91,10</p> <p>4 Cyl. Diesel 136HP 4D56 TDI EURO V <u>2014 -</u> L200</p>	<p>17-1592280 STD 17-1592283 0.50</p>	<p>A = 48,150 B = 78,150 C = 16,750 E = -2,000 F = -2,500 CD= 46,900</p> <p>Segman Taşıyıcı (Ring Carrier)</p> <p>Sert Anotlama (Hard Anodising)</p> <p>Yag Galerisi (Oil Gallery)</p>	<p>RJ20083A00 -STD RJ20083C00 -0.50</p> <p>2,500 () CrI SM 1,980 () RN CrI 3,000 () GN</p>	<p>ø32,0 x 75,0</p>			
<p>ø93,00</p> <p>8 Cyl. Benzin 4700 cc</p> <p>CPW6925 8V 4.7LT Power Tech V8 <u>1999 - 2007</u></p> <p>Dakota (AN) 2000/2007 Durango (DN) 2000/2007 Commander (XK/XH) 2006/2007 Grand Cherokee (WJ/WG/WK/WH) 1999-2007 Ram1500 Pickup 2002/2007 Raider 2006/2007</p>	<p>17-9710320 STD 17-9710323 0.50</p>	<p>A = 31,800 B = 53,800</p>	<p>RK97109300010 -STD RK97109300013 -0.50</p> <p>1,500 () GI 1,500 () Cr 3,000 () Cr</p>	<p>ø24,0 x 59,0</p>			



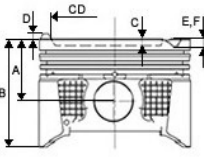









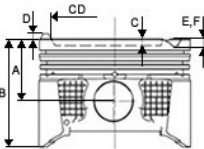







							
Motor /Engine	Ref. No. Kit 1	Ölçüler /Dimensions	Segman /Rings	Pim	Gömlek /Liner	Kit 2	Info
<p>ø95,00</p> <p>4 Cyl. Diesel 2835 cc 69 Kw (794 Ps) 21:1 4M40 0A Euro 1 <u>2006 -....</u></p> <p>FUSO CANTER FUSO CANTER FE711</p>	<p>18-1592500 STD 18-1592503 0.50</p>	<p>A = 51,700 B = 91,700 C = 1,200 E = -1,350 F = -0,400</p> <p>Segman Taşıyıcı (Ring Carrier)</p> <p>Sert Anotlama (Hard Anodising)</p> <p>Sac Plaka (Steel Support)</p> <p>Yag Püskürt. Oyugu (Oil Cut-Out)</p>	<p>RJ20661A00 -STD RJ20661C00 -STD</p> <p>2,300 () GN SM 2,000 () RN 4,000 () GN</p>	<p>ø32,0 x 80,0</p>			
<p>ø95,00</p> <p>4 Cyl. Diesel 2977 cc 97kW 132PS 4M42 <u>2005 -....</u></p> <p>FE 730 Euro 4 FE 839 Fuso Canter</p>	<p>18-1592510 STD 18-1592513 0.50</p>	<p>A = 51,000 B = 77,000 C = 17,000 E = -1,200 F = -0,350 CD= 55,500</p> <p>Segman Taşıyıcı (Ring Carrier)</p> <p>Yag Galerisi (Oil Gallery)</p> <p>Yag Püskürt. Oyugu (Oil Cut-Out)</p>	<p>RJ20585A00 -STD RJ20585C00 -0.50</p> <p>2,306 () GN SMX 2,000 () RN 4,000 ()</p>	<p>ø32,0 x 80,0</p>			

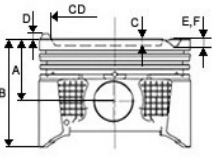







							
Motor /Engine	Ref. No. Kit 1	Ölçüler /Dimensions	Segman /Rings	Pim	Gömlek /Liner	Kit 2	Info
<p>ø100,00</p> <p>4 Cyl. Diesel 3298 cc 69 Kw (94 Ps) 17 5:1 4D31 QA</p> <p>Canter 3300 (FE 444) H350</p>	<p>18-1550010 STD 18-1550013 0.50</p>	<p>A = 60,700 B = 110,700 C = 18,100 CD= 52,500</p> <p>Segman Taşıyıcı (Ring Carrier)</p> <p>Sac Plaka (Steel Support)</p>	<p>RJ20016A00 -STD RJ20016C00 -0.50</p> <p>3,000 () RN CrI FX 2,000 () 5,000 ()</p>	<p>ø18,0 x 52,3</p>			<p>+ 0,47 + 0,69</p>
<p>ø100,00</p> <p>4 Cyl. Diesel 3298 cc</p> <p>D4AE 1995 -..... H350 TD HD77 TD</p>	<p>18-1550600 STD 18-1550603 0.50</p>	<p>A = 60,650 B = 110,650 C = 17,400 CD= 54,700</p> <p>Segman Taşıyıcı (Ring Carrier)</p>	<p>RJ40100A00 -STD RJ40100C00 -0.50</p> <p>3,000 () FM 2,000 () 4,000 ()</p>	<p>ø34,0 x 84,0</p>			



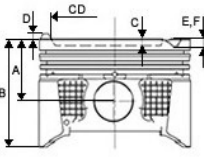



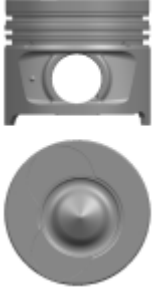
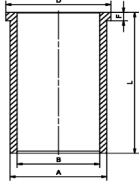
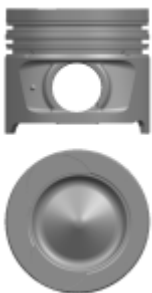
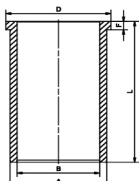

							
Motor /Engine	Ref. No. Kit 1	Ölçüler /Dimensions	Segman /Rings	Pim	Gömlek /Liner	Kit 2	Info
<p>ø104,00</p> <p>4 Cyl. Diesel 3908cc 96 KW 130PS 4D34 1 ATA EUROII</p> <p>659 Canter Prestij TDI-HD 65-HD 72-HD 82</p>	<p>18-1550020 STD</p> <p>18-1550023 0.50</p>	<p>A = 62,200 B = 112,200 C = 23,000 CD= 49,000</p> <p>Yag Galerisi (Oil Gallery)</p> <p>Sac Plaka (Steel Support)</p> <p>Yag Püskürt. Oyugu (Oil Cut-Out)</p>	<p>RJ20941A00 -STD RJ20941C00 -0.50</p> <p>3,000 () RN FM 2,000 () 4,000 ()</p>	<p>ø36,0 x 88,0</p>			<p>+ 0,60 + 0,70</p>
<p>ø104,00</p> <p>4 Cyl. Diesel 3908 cc 4D34 QA (YENİ TİP)</p> <p>659 Canter</p>	<p>18-1550030 STD</p> <p>18-1550030-20 STD (-0.20 mm)</p> <p>18-1550033 0.50</p>	<p>A = 62,200 B = 112,200 C = 20,600 CD= 52,000</p> <p>Segman Taşıyıcı (Ring Carrier)</p> <p>Sac Plaka (Steel Support)</p> <p>Yag Püskürt. Oyugu (Oil Cut-Out)</p>	<p>RJ20941A00 -STD RJ20941C00 -0.50</p> <p>3,000 () RN FM 2,000 () 4,000 ()</p>	<p>ø34,0 x 84,0</p>			



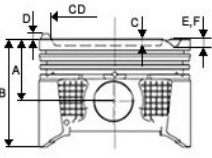



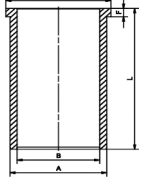
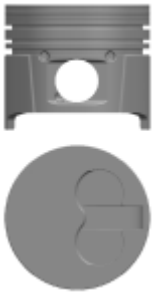

							
Motor /Engine	Ref. No. Kit 1	Ölçüler /Dimensions	Segman /Rings	Pim	Gömlek /Liner	Kit 2	Info
<p>ø104,00</p> <p>4 Cyl. Diesel 3567 cc 69kW 94PS 4D32/2A <u>2000 -</u></p> <p>Canter Fe 515 Canter FE 635</p>	<p>18-1591700 STD 18-1591703 0.50</p>	<p>A = 60,730 B = 110,730 C = 18,900 CD= 52,000</p> <p>Segman Taşıyıcı (Ring Carrier)</p> <p>Sac Plaka (Steel Support)</p>		<p>ø34,0 x 84,0</p>			



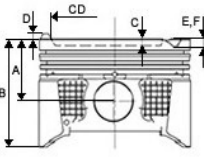



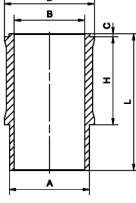

							
Motor /Engine	Ref. No. Kit 1	Ölçüler /Dimensions	Segman /Rings	Pim	Gömlek /Liner	Kit 2	Info
<p>ø69,00</p> <p>4 Cyl. Benzin 1149 cc 44 Kw (60 Ps) D7F F4P 44KW 700/701/702 706/710/720/ <u>1996 -....</u></p> <p><i>Clio 1.2i Kangoo 1.2i Twingo 1.2i</i></p>	<p>18-8010040 STD 18-8010043 0.50</p>	<p>A = 27,150 B = 50,500</p>	<p>RE49330000 -STD RE49330050 -0.50</p> <p>1,500 (500) Cr P IF 1,500 (501) P IFU 2,500 (604) Cr P</p>	<p>ø17,0 x 53,7</p>			
<p>ø72,20</p> <p>4 Cyl. Benzin 1332 cc 120 135kW 163 184 PS M 282.194 H5H 450/470/480/490</p> <p><u>2018 -</u></p> <p><i>CAPTUR I (J5_ H5_ HF) 1.3 Tce CLIO V (B7_) 1.3 Tce GRAND SCENIC IV KADJAR (HA_ HL_ HC) 1.3 Tce MEGANE IV Grandtour MEGANE IV Sedan/Hatchback SCENIC IV TALISMAN LODGY (J5_) 1.3 Tce DUSTER (FM_) 1.3 Tce</i></p>	<p>18-8010020 STD 18-8010023 0.50</p>	<p>A = 31,550 B = 49,050 C = 5,100 E = -3,250 F = -3,850 CD= 47,300</p> <p>Segman Taşıyıcı (Ring Carrier)</p>	<p>RE49580000 -STD RE49580050 -0.50</p> <p>1,200 (500) IFU NIT S 1,500 (508) Cr P 2,000 (700) NIT S</p>	<p>ø20,0 x 47,0</p>			

Motor /Engine	Ref. No. Kit 1	Ölçüler /Dimensions	Segman /Rings	Pim	Gömlek /Liner	Kit 2	Info
							
ø72,20 3/4 Cyl. Benzin 898/999 1197 cc 51/56/66/ 84//85/74/83/85/97 87/88/96kW 96/113/116 118/120/130HP H5F 400/403/408 402/404/412 1.2 TCE <u>2013/06 -....</u> CAPTUR (J5_,H5) H4B-H4D DFAC 1.2 Tce 120/1.2 T QASHQAI	17-8010060 STD 17-8010063 0.50	A = 31,300 B = 48,400 C = 4,800 E = -2,600 F = -2,000 CD= 1,100 Segman Taşıyıcı (Ring Carrier)	RE49580000 -STD RE49580050 -0.50 1,200 (500) IFU NIT S 1,500 (508) Cr P 2,000 (700) NIT S	ø20,0 x 49,0			
	ø72,20 3 Cyl. Benzin 898/999 cc 56/66 kW 76/90 PS H4B 400/401/408/453 <u>2012 -....</u> III TWINGO SYMBOL SCENIC MEGANE KANGOO GRANDTORU CAPTUR SANDERO II LOGAN MCV II LOGY JOGGER CLIO IV STEPAY	17-8010070 STD 17-8010073 0.50	A = 31,300 B = 48,800 C = 4,600 E = -0,800 F = -3,400 CD= 61,900 Sert Anotlama (Hard Anodising)	RE49580000 -STD RE49580050 -0.50 1,200 (500) IFU NIT S 1,500 (508) Cr P 2,000 (700) NIT S	ø20,0 x 43,3		
							

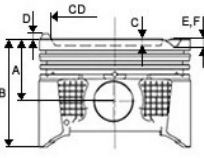







							
Motor /Engine	Ref. No. Kit 1	Ölçüler /Dimensions	Segman /Rings	Pim	Gömlek /Liner	Kit 2	Info
<p>ø76,00</p> <p>4 Cyl. Diesel 1461 cc 74 Kw (100 Ps) K9K 728 Euro 3 <u>2004 -...</u></p> <p><i>Megane II 1,5 DCI</i> <i>Clio</i></p>	<p>18-8088330 STD <i>18-8088330-20 STD</i> <i>(-0.20 mm)</i></p> <p>18-8088333 0.50 <i>18-8088333-20 0.50</i> <i>(-0.20 mm)</i></p> <p>18-8088338 1.00</p> 	<p>A = 41,700 B = 66,000 C = 14,000 E = -0,430 F = -0,250 CD= 39,700</p> <p>Segman Taşıyıcı (Ring Carrier)</p> <p>Yag Galerisi (Oil Gallery)</p> <p>Yag Püskürt. Oyugu (Oil Cut-Out)</p>	<p>RE49400000 -STD RE49400050 -0.50 RE49400100 -1.00</p> <p>2,000 (500) CKP 2,000 (501) P 2,500 (604) CrP</p>	<p>ø26,0 x 60,0</p>	<p>G79601420K_1</p> <p>A= 79,600 B= 75,300 D= 81,500 F= 5,500 H= 0,000 L= 142,000</p> 		<p>+0.25 +0.30</p>
<p>ø76,00</p> <p>4 Cyl. Diesel 1461cc 78 Kw (106 Ps) Turbo, Intercooler K9K 732 Euro4 K9K 764 Euro4 K9K 780 Euro4 K9K 804 <u>2005 -....</u></p> <p><i>Megane II 1.5 dCi</i> <i>Scenic 1.5 dCi</i> <i>Clio Grandtour 1.5 dCi</i> <i>Clio III 1.5 dCi</i> <i>Modus 1.5 dCi</i> <i>Laguna III 1.5 dCi</i> <i>Kangoo 1.5 dCi</i> <i>Kangoo Be Bop 1.5 dCi</i> <i>Kangoo Express 1.5 dCi</i></p>	<p>18-8088440 STD <i>18-8088440-20 STD</i> <i>(-0.20 mm)</i></p> <p>18-8088443 0.50 <i>18-8088443-20 0.50</i> <i>(-0.20 mm)</i></p> <p>18-8088448 1.00</p> 	<p>A = 41,700 B = 66,000 C = 12,800 E = -0,250 F = -0,430 CD= 49,000</p> <p>Segman Taşıyıcı (Ring Carrier)</p> <p>Yag Galerisi (Oil Gallery)</p> <p>Yag Püskürt. Oyugu (Oil Cut-Out)</p>	<p>RE49400000 -STD RE49400050 -0.50 RE49400100 -1.00</p> <p>2,000 (500) CKP 2,000 (501) P 2,500 (604) CrP</p>	<p>ø26,0 x 60,0</p>	<p>G79601420K_1</p> <p>A= 79,600 B= 75,300 D= 81,500 F= 5,500 H= 0,000 L= 142,000</p> 		<p>+0.25 +0.30</p>



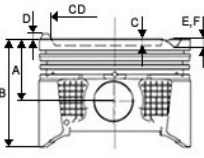





Motor /Engine	Ref. No. Kit 1	Ölçüler /Dimensions	Segman /Rings	Pim	Gömlek /Liner	Kit 2	Info
							
ø76,00 4 Cyl. Diesel 1461 cc 81 Kw (110 Ps) K9K Eur 6 2009 -.... Juke (F15) 1.5 dCi Qashqai II Suv (J11-J1) Kangoo Megane III Hatchback	18-8092810 STD 18-8092813 0.50 18-8092818 1.00	A = 41,709 B = 66,000 C = 12,860 E = -0,430 CD= 47,000 Segman Taşıyıcı (Ring Carrier) Yag Galerisi (Oil Gallery) Yag Püskürt. Oyugu (Oil Cut-Out)	RE49400000 -STD RE49400050 -0.50 RE49400100 -1.00 2,000 (500) CKP 2,000 (501) P 2,500 (604) CrP	ø26,0 x 60,0	G79601420K_1 A= 79,600 B= 75,300 D= 81,500 F= 5,500 H= 0,000 L= 142,000 		
ø77,00 4 Cyl. Diesel 1527cc 37 42 Kw (50 57 Ps) VJX VJY VJZ (TUD5) TUD 5 1994 -.... 106 II Micra 1.5D Saxo 1.5D XSara 1.5D 106 1.5D 2 Serisi	18-7550420 STD 18-7550422 0.40	A = 40,400 B = 66,300 C = 1,580 E = -2,040 Yag Püskürt. Oyugu (Oil Cut-Out)	RE47270000 -STD RE47270040 -0.40 2,000 (500) Cr P 1,750 (501) P 3,000 (604) Cr P	ø23,0 x 60,0			+1,04 +1,14
							



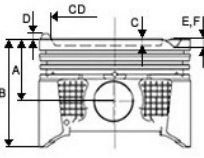



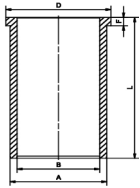
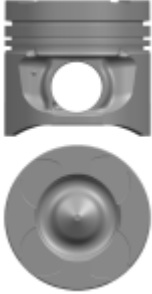

							
Motor /Engine	Ref. No. Kit 1	Ölçüler /Dimensions	Segman /Rings	Pim	Gömlek /Liner	Kit 2	Info
<p>ø77,00</p> <p>4 Cyl. Benzin 1565 cc 69 Kw (94 Ps) 9:1 C2L <u>1985 - 1995</u></p> <p><i>R 11 Rainbow</i> <i>R 21 Optima</i> 1985-1995</p>	<p>18-8010200 STD Gömleklili Kodu 19-8010200 STD</p>	<p>A = 34,000 B = 60,500 C = 1,950 CD= 65,000</p>	<p>RE49350000 -STD</p> <p>1,750 (500) Cr P 2,000 (508) P 4,000 (603) P</p>	<p>ø20,0 x 64,0</p>	<p>G80901340S_1</p> <p>A= 81,000 B= 77,000 D= 90,100 F= 0,000 H= 95,000 L= 134,000</p> 		
<p>ø78,00</p> <p>H4J <i>Megane 3</i></p>	<p>18-8010210 STD 18-8010213 0.50</p>	<p>A = 34,300 B = 52,300 C = 7,680 E = -2,800 F = -6,500</p> <p>Sert Anotlama (Hard Anodising)</p>	<p>RE49500000 -STD RE49500050 -0.50</p> <p>1,200 (500) NitB S IF 1,200 (501) P 2,000 (700) Nit S</p>	<p>ø20,0 x 52,2</p>			



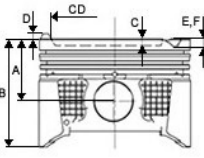



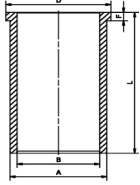
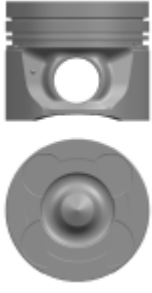

							
Motor /Engine	Ref. No. Kit 1	Ölçüler /Dimensions	Segman /Rings	Pim	Gömlek /Liner	Kit 2	Info
<p>ø78,00</p> <p>4 Cyl. Benzin 1598 cc 84 KW 115 PS H4M <u>2015 -</u> Duster Megane IV</p>	<p>18-8010220 STD 18-8010223 0.50</p>	<p>A = 28,750 B = 48,250 E = -3,750</p> <p>Sert Anotlama (Hard Anodising)</p>	<p>RE49500000 -STD RE49500050 -0.50</p> <p>1,200 (500) NitB S IF 1,200 (501) P 2,000 (700) Nit S</p>	<p>ø19,0 x 53,5</p>			
<p>ø80,00</p> <p>4 Cyl. Diesel 1598cc 96 KW 130PS R9M 402 <u>2015 -</u> Qashgai (2015 -)</p>	<p>18-8092820 STD 18-8092823 0.50</p>	<p>A = 46,000 B = 70,500 C = 12,350 E = -0,300 CD= 46,500</p> <p>Segman Taşıyıcı (Ring Carrier)</p> <p>Yag Galerisi (Oil Gallery)</p> <p>Yag Püskürt. Oyugu (Oil Cut-Out)</p>	<p>RE49510000 -STD RE49510050 -0.50</p> <p>2,000 (500) Cpk 1,750 (501) P IFU 2,000 (604) Cr P</p>	<p>ø30,0 x 60,0</p>			



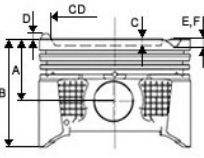









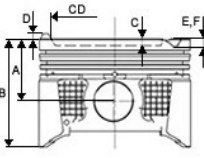





							
Motor /Engine	Ref. No. Kit 1	Ölçüler /Dimensions	Segman /Rings	Pim	Gömlek /Liner	Kit 2	Info
<p>ø82,70</p> <p>4 Cyl. Benzin 2000 cc F3R 722/723/728/729 1994 -....</p> <p>Laguna 1 Mégane Scenic 2.0</p>	<p>18-8010400 STD 18-8010403 0.50</p>	<p>A = 36,170 B = 60,000 C = 9,000 CD= 67,400</p> <p>Sac Plaka (Steel Support)</p>	<p>RE49300000 -STD RE49300050 -0.50</p> <p>1,500 (500) CrB Fe S IF 1,750 (501) P 3,000 (700) Cr P S</p>	<p>ø21,0 x 57,0</p>			
<p>ø85,00</p> <p>4 Cyl. Diesel 2298 cc 74/107 KW (101/146 Ps) M9T EURO 4/5 ÇİFT TURBOLU ARAÇLAR M9T 710/702/700 2010 -....</p>	<p>18-8092890 STD 18-8092890-20 STD (-0.20 mm) 18-8092893 0.50 18-8092893-20 0.50 (-0.20 mm)</p>	<p>A = 47,833 B = 74,000 C = 16,200 CD= 50,000</p> <p>Segman Taşıyıcı (Ring Carrier)</p> <p>Yag Galerisi (Oil Gallery)</p>	<p>RE49540000 -STD RE49540050 -0.50</p> <p>2,000 (503) CK 1,750 (501) IFU CR 2,000 (604) NIT</p>	<p>ø32,0 x 67,5</p>			



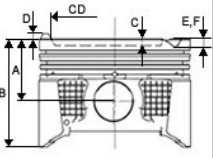



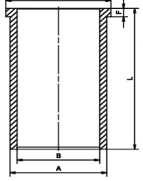
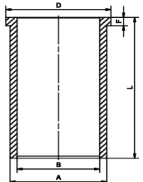

							
Motor /Engine	Ref. No. Kit 1	Ölçüler /Dimensions	Segman /Rings	Pim	Gömlek /Liner	Kit 2	Info
<p>ø87,00</p> <p>4 Cyl. Diesel 2283 cc 55kw 75PS 22,2:1 LD23 <u>1995 -</u></p> <p><i>Cargo Serena Trade Vanetta</i></p>	<p>18-8051310 STD 18-8051313 0.50</p>	<p>A = 47,230 B = 76,230 C = 2,280 E = -1,150</p> <p>Segman Taşıyıcı (Ring Carrier)</p> <p>Sac Plaka (Steel Support)</p> <p>Yag Püskürt. Oyugu (Oil Cut-Out)</p>		<p>ø26,0 x 63,7</p>			
<p>ø89,00</p> <p>4 Diesel, 2464 cm³ 74/107 kW (101/146 PS) 18:1 18,1:1,16 Ventile G9U 630 G9U 632 G9U 650 <u>10/2003</u></p> <p><i>INTERSTAR DCI 100/120/150 PRIMA STAR DCI 150 MOVANO-A 2.5 CDTI VIVARO 2.5 CDTI/DTI TRAFIC II 2.5 DCI MASTER II 2.5 DCI</i></p>	<p>18-3092350 STD 18-3092353 0.50</p>	<p>A = 53,075 B = 83,090 C = 16,300 E = -2,000 F = -1,700 CD= 48,000</p> <p>Segman Taşıyıcı (Ring Carrier)</p> <p>Yag Galerisi (Oil Gallery)</p> <p>Yag Püskürt. Oyugu (Oil Cut-Out)</p>	<p>RE49490000 -STD RE49490050 -0.50</p> <p>3,000 (503) Cr P 1,750 (508) P 2,500 (604) Nit S</p>	<p>ø31,0 x 68,0</p>	<p>G92001680K_1</p> <p>A= 92,000 B= 88,300 D= 93,500 F= 5,000 H= 0,000 L= 168,000</p>		



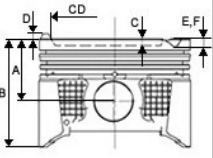



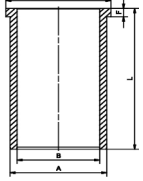
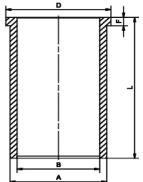

							
Motor /Engine	Ref. No. Kit 1	Ölçüler /Dimensions	Segman /Rings	Pim	Gömlek /Liner	Kit 2	Info
<p>ø89,00</p> <p>4 Cyl. Diesel 2488 cc 110 Kw (150 Ps) 17,5:1 YD25DDTI TCI <u>2003 -....</u> D 22 Pick Up Skystar</p>	<p>18-8050010 STD 18-8050013 0.50</p> 	<p>A = 48,850 B = 80,100 C = 18,100 E = -0,750 F = -1,200 CD= 43,000</p> <p>Segman Taşıyıcı (Ring Carrier)</p> <p>Yag Galerisi (Oil Gallery)</p> <p>Yag Püskürt. Oyugu (Oil Cut-Out)</p>	<p>RJ23265A00 -STD RJ23265C00 -0.50</p> <p>2,000 () GN SM 2,000 () 3,000 () DN</p>	<p>ø28,0 x 61,0</p>	<p>G89001660K_1</p> <p>A= 91,500 B= 88,300 D= 92,500 F= 5,000 H= 0,000 L= 166,000</p> 		
<p>ø89,00</p> <p>4 Cyl. Diesel 2500 cc 126/128 Kw (171/174 Ps) YD25DDTI <u>2005 -....</u> Navara 2.5 dci 16V Pathfinder 2.5 dci 16V</p>	<p>18-8092330 STD 18-8092333 0.50</p> 	<p>A = 48,900 B = 73,900 C = 19,200 E = -1,150 F = -1,200 CD= 44,400</p> <p>Segman Taşıyıcı (Ring Carrier)</p> <p>Yag Galerisi (Oil Gallery)</p> <p>Yag Püskürt. Oyugu (Oil Cut-Out)</p>	<p>RJ23265A00 -STD RJ23265C00 -0.50</p> <p>2,000 () GN SM 2,000 () 3,000 () DN</p>	<p>ø28,0 x 70,9</p>			



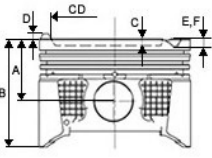

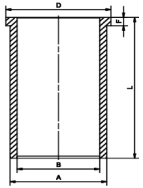

							
Motor /Engine	Ref. No. Kit 1	Ölçüler /Dimensions	Segman /Rings	Pim	Gömlek /Liner	Kit 2	Info
<p>ø89,00</p> <p>4 Cyl. Diesel 2488 cc 106 Kw 76/81/ KW 103/110/144 Ps YD25DDTi (D40) Renault Truck DXi 2.5 <u>2008 -....</u> Navara 2.5 dci</p>	<p>18-8092340 STD 18-8092343 0.50</p>	<p>A = 48,850 B = 73,800 C = 17,400 E = -1,200 F = -0,750 CD= 47,400</p> <p>Segman Taşıyıcı (Ring Carrier)</p> <p>Yag Galerisi (Oil Gallery)</p>	<p>RJ23265A00 -STD RJ23265C00 -0.50</p> <p>2,000 () GN SM 2,000 () 3,000 () DN</p>	<p>ø28,0 x 70,9</p>			
<p>ø96,00</p> <p>4 Cyl. Diesel 3000 cc 89/125 Kw (121/170 Hp) ZD30DDTi <u>1987 -....</u> CABSTAR (F24) NT400 CABSTAR (F24F) PATROL GRV (Y61) ELGRAND (E50) PATHFINDER II (R50) NAVARA (D22) CARAVAN BUS/KASTEN TERRANO (R20)</p>	<p>18-1592600 STD 18-1592603 0.50</p>	<p>A = 50,100 B = 78,100 C = 18,400 CD= 54,500</p> <p>Segman Taşıyıcı (Ring Carrier)</p> <p>Yag Galerisi (Oil Gallery)</p> <p>Yag Püskürt. Oyugu (Oil Cut-Out)</p>	<p>RJ23177A00 -STD RJ23177C00 -0.50</p> <p>2,500 () GN SM 2,000 () 2,000 () GN</p>	<p>ø33,0 x 78,0</p>			

							
Motor /Engine	Ref. No. Kit 1	Ölçüler /Dimensions	Segman /Rings	Pim	Gömlek /Liner	Kit 2	Info
<p>ø96,00</p> <p>4 Cyl. Diesel 2700 cc 100PS BD30 <u>1998 -</u> Levend 3,0 TD 27</p>	<p>18-1592700 STD 18-1592703 0.50</p>	<p>A = 53,100 B = 89,600 C = 20,100 CD= 44,000</p> <p>Yag Galerisi (Oil Gallery)</p> <p>Sac Plaka (Steel Support)</p> <p>Yag Püskürt. Oyugu (Oil Cut-Out)</p>	<p>RJ23176A00 -STD RJ23176C00 -0.50</p> <p>2,500 () GN SX 2,000 () 3,000 () GN</p>	<p>ø30,0 x 80,0</p>			



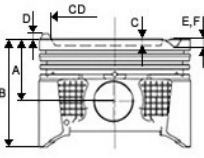
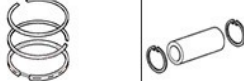





Motor /Engine	Ref. No. Kit 1	Ölçüler /Dimensions	Segman /Rings	Pim	Gömlek /Liner	Kit 2	Info
							
ø69,60 4 Cyl. Diesel 1248cc 75 HP/95 70Kw 16,8:1 1.3 75Hp Multi.jet II 16v Euro 5 95 PS A 13DTE 2009 - 1.3 CDTi (Astra J Corsa D Meriva) 1.3 D Multijet MITO STRADA Pick-up PANDA FIORINO Kasten/Kombi QUBO IDEA PUNTO Van AVEO Schrägheck(Euro-4)1	18-2092250 STD 18-2092250-20 STD (-0.20 mm) 18-2092250-40 STD (-0.40 mm) 18-2092252 0.40 18-2092252-20 0.40 (-0.20 mm) 18-2092252-40 0.40 (-0.40 mm) 18-2092254 0.60 18-2092254-20 0.60 (-0.20 mm) 18-2092257 0.80 18-2092257-20 0.80 (-0.20 mm) 18-2092257-40 0.80 (-0.40 mm)	A = 40,430 B = 62,430 C = 12,700 E = -1,153 F = -0,904 CD= 37,000 Segman Taşıyıcı (Ring Carrier) Yag Galerisi (Oil Gallery) Yag Püskürt. Oyugu (Oil Cut-Out)	RE22860000 -STD RE22860040 -0.40 RE22860060 -0.60 RE22860080 -0.80 RE22860100 -1.00 1,500 (500) Cr P 1,500 (501) P 2,000 (604) Nit S	ø23,0 x 56,7	G69601420K_1 A= 72,500 B= 68,900 D= 74,000 F= 5,000 H= 0,000 L= 142,000 	0,67 0,77 mm Conta Yle + 0,028 + 0,127 0,77 0,87 mm Conta +0,127 +0,227 0,87 0,97 mm Conta + 0,228 + 0,327	
ø69,60 4 Cyl. Diesel 1248cc 75 HP 55/70 KW 75/95 PS B13 DTE/DTR 1.3 CDTi (EUR 6) 2006 - 1.3 CDTi CORSA E Van (X15) CORSA E (X15) CORSAVAN Mk III (D) (S07) CORSAVAN MkIV E (X15) CORSAVAN Mk IV € (X15) MITO	18-2092260 STD 18-2092260-20 STD (-0.20 mm) 18-2092260-40 STD (-0.40 mm) 18-2092262 0.40 18-2092262-20 0.40 (-0.20 mm) 18-2092262-40 0.40 (-0.40 mm) 18-2092267 0.80 18-2092267-20 0.80 (-0.20 mm) 18-2092267-40 0.80 (-0.40 mm)	A = 40,430 B = 62,430 C = 12,000 CD= 42,300 Segman Taşıyıcı (Ring Carrier) Yag Galerisi (Oil Gallery) Yag Püskürt. Oyugu (Oil Cut-Out)	RE22860000 -STD RE22860040 -0.40 RE22860060 -0.60 RE22860080 -0.80 RE22860100 -1.00 1,500 (500) Cr P 1,500 (501) P 2,000 (604) Nit S	ø23,0 x 56,7	G69601420K_1 A= 72,500 B= 68,900 D= 74,000 F= 5,000 H= 0,000 L= 142,000 		

Motor /Engine	Ref. No. Kit 1	Ölçüler /Dimensions	Segman /Rings	Pim	Gömlek /Liner	Kit 2	Info
							
ø69,60 4 Cyl. Diesel 1248cc 90 HP 1.3 90HP MULTIJET II 1.6V EURO 5 2009 - Stop/Start Motorlara Ait DOBLO CARGO PRATICO	18-2092320 STD 18-2092320-20 STD (-0.20 mm) 18-2092320-40 STD (-0.40 mm) 18-2092322 0.40 18-2092322-20 0.40 (-0.20 mm) 18-2092322-40 0.40 (-0.40 mm) 18-2092324 0.60 18-2092324-20 0.60 (-0.20 mm) 18-2092327 0.80 18-2092327-20 0.80 (-0.20 mm) 18-2092327-40 0.80 (-0.40 mm)	A = 40,300 B = 62,430 C = 12,700 E = -1,153 F = -0,904 CD= 37,000 Segman Taşıyıcı (Ring Carrier) Yag Galerisi (Oil Gallery) Yag Püskürt. Oyugu (Oil Cut-Out)	RE22860000 -STD RE22860040 -0.40 RE22860060 -0.60 RE22860080 -0.80 RE22860100 -1.00 1,500 (500) Cr P 1,500 (501) P 2,000 (604) Nit S	ø23,0 x 56,7	G69601420K_1 A= 72,500 B= 68,900 D= 74,000 F= 5,000 H= 0,000 L= 142,000		0,67 0,77 mm Conta + 0,028 + 0,127 0,77 0,87 mm Conta +0,127 +0,227 0,87 0,97 mm Conta + 0,228 + 0,327
ø69,60 4 Cyl. Diesel 1248 cc 70 Ps 18:1 Turbo, Common Rail 16v 188.A8.000 Euro 4 188 A9.000 Euro 4 199 A2.000 Eur 2003 - Agila 1.3 Corsa 1.3 Meriva 1.3 Tigra 1.3 Albea 1.3 Multijet Doblo 1.3 Multijet Palio 1.3 Multijet Suzuki 1.3 Multijet	18-3050230 STD 18-3050230-20 STD (-0.20 mm) 18-3050230-40 STD (-0.40 mm) 18-3050232 0.40 18-3050232-20 0.40 (-0.20 mm) 18-3050232-40 0.40 (-0.40 mm) 18-3050234 0.60 18-3050234-20 0.60 (-0.20 mm) 18-3050234-40 0.60 (-0.40 mm) 18-3050237 0.80 18-3050237-20 0.80 (-0.20 mm) 18-3050237-40 0.80 (-0.40 mm)	A = 40,430 B = 63,430 C = 12,400 E = -1,000 CD= 38,000 Segman Taşıyıcı (Ring Carrier) Yag Püskürt. Oyugu (Oil Cut-Out)	RE22030000 -STD RE22030040 -0.40 RE22030060 -0.60 RE22030080 -0.80 2,000 (500) Cr P 1,500 (501) P 2,000 (604) Nit S	ø23,0 x 56,7	G69601420K_1 A= 72,500 B= 68,900 D= 74,000 F= 5,000 H= 0,000 L= 142,000		0,67 0,77 mm Conta +0,02 +0,13 0,77 0,87 mm Conta +0,13 +0,23 0,87 0,97 mm Conta +0,23 +0,33

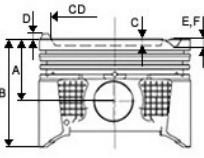





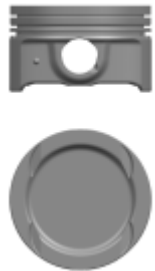

Motor /Engine	Ref. No. Kit 1	Ölçüler /Dimensions	Segman /Rings	Pim	Gömlek /Liner	Kit 2	Info
							
ø69,60 4 Cyl. Diesel 1248 cc 55KW 75PS B13 DTC 2016 - Corsa E-Combo 1.3 CDTI	18-3050250 STD 18-3050250-20 STD (-0.20 mm) 18-3050250-40 STD (-0.40 mm) 18-3050252 0.40 18-3050252-20 0.40 (-0.20 mm) 18-3050252-40 0.40 (-0.40 mm) 18-3050254 0.60 18-3050254-20 0.60 (-0.20 mm) 18-3050254-40 0.60 (-0.40 mm) 18-3050257 0.80 18-3050257-20 0.80 (-0.20 mm) 18-3050257-40 0.80 (-0.40 mm)	A = 40,430 B = 63,130 C = 12,000 E = -1,800 F = -1,700 CD= 41,900 Segman Taşıyıcı (Ring Carrier)	RE22860000 -STD RE22860040 -0.40 RE22860060 -0.60 RE22860080 -0.80 RE22860100 -1.00 1,500 (500) Cr P 1,500 (501) P 2,000 (604) Nit S	ø23,0 x 56,7			
ø69,60 4 Cyl. Diesel 1248 cc 66 Kw (90 Ps) 17,6:1 199A3000 Multijet Euro 5 Z13 DTH A13DTE Euro 5 16V 2009 - ASTRA J CORSA D Grande Punto1.3CDTI 16V Linea Grande Punto	18-3082550 STD 18-3082550-20 STD (-0.20 mm) 18-3082550-40 STD (-0.40 mm) 18-3082552 0.40 18-3082552-20 0.40 (-0.20 mm) 18-3082552-40 0.40 (-0.40 mm) 18-3082554 0.60 18-3082554-20 0.60 (-0.20 mm) 18-3082554-40 0.60 (-0.40 mm) 18-3082557 0.80 18-3082557-20 0.80 (-0.20 mm) 18-3082557-40 0.80 (-0.40 mm)	A = 40,430 B = 62,430 C = 12,400 E = -0,904 F = -1,154 CD= 38,000 Segman Taşıyıcı (Ring Carrier) Yag Galerisi (Oil Gallery) Yag Püskürt. Oyugu (Oil Cut-Out)	RE22030000 -STD RE22030040 -0.40 RE22030060 -0.60 RE22030080 -0.80 2,000 (500) Cr P 1,500 (501) P 2,000 (604) Nit S	ø23,0 x 56,7	G69601420K_1 A= 72,500 B= 68,900 D= 74,000 F= 5,000 H= 0,000 L= 142,000		0,67 0,77 mm Conta +0,028 +0,127 0,77 0,87 mm Conta +0,127 +0,227 0,87 0,97 mm Conta +0,228 +0,327

							
Motor /Engine	Ref. No. Kit 1	Ölçüler /Dimensions	Segman /Rings	Pim	Gömlek /Liner	Kit 2	Info
<p>ø69,70</p> <p>4 Cyl. Benzin 1229cc 63kw 86 PS 1T2G1 <u>2010 -</u></p> <p>Aveo II 1.2i 16V Corsa D 1.2i 16V</p>	<p>18-1010150 STD 18-1010153 0.50</p>	<p>A = 27,720 B = 47,720 C = 4,300 E = -1,100 F = -1,570 CD= 63,300</p> <p>Yag Püskürt. Oyugu (Oil Cut-Out)</p>	<p>RE16010000 -STD RE16010050 -0.50</p> <p>1,200 (300) 1,200 (300) 2,000 (300)</p>	<p>ø17,0 x 53,5</p>			
<p>ø72,00</p> <p>4 Cyl. Benzin, 1200 cm³ 33 kW (45 hp), 10:1 X12SZ <u>1992 -</u></p> <p>Corsa Nova</p>	<p>18-3010170 STD 18-3010173 0.50</p>	<p>A = 32,050 B = 59,000 C = 2,800 CD= 60,000</p>	<p>RE43000000 -STD RE43000050 -0.50</p> <p>1,500 (500) CrP 1,500 (508) P 3,000 (700) CrP</p>	<p>ø18,0 x 50,9</p>			

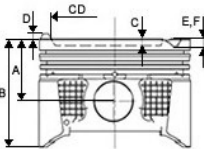









							
Motor /Engine	Ref. No. Kit 1	Ölçüler /Dimensions	Segman /Rings	Pim	Gömlek /Liner	Kit 2	Info
<p>ø72,00</p> <p>4 Cyl. Benzin, 1200 cm³ 33 kW (45 hp), 9:1 C12NZ 12NZ <u>1990-1992</u> (8 Ventil) Corsa-B 1.2 Transporter Combo 1.2</p>	<p>18-3010180 STD 18-3010183 0.50</p>	<p>A = 32,050 B = 58,050 C = 4,100 CD= 63,550</p>	<p>RE43000000 -STD RE43000050 -0.50</p> <p>1,500 (500) CrP 1,500 (508) P 3,000 (700) CrP</p>	<p>ø18,0 x 50,9</p>			
<p>ø72,50</p> <p>4 Cyl. Benzin 1364 cc 103/110KW 140/150 PS GÜÇLENDİRİLMİŞ A14NET TURBO ECOTEC (2011 ...) B14NEH TURBO (2015 ...) <u>2011/2015 -</u> Astra J Corsa E</p>	<p>18-3010110 STD 18-3010110-30 STD 18-3010113 0.50 18-3010113-30 0.50</p>	<p>A = 25,870 B = 44,180 C = 2,900 E = -2,000</p> <p>Segman Taşıyıcı (Ring Carrier)</p> <p>Sert Anotlama (Hard Anodising)</p>	<p>RE43500000 -STD RE43500050 -0.50</p> <p>1,200 (504) NitB S IF 1,200 (508) P 2,000 (700) Nit S</p>	<p>ø18,0 x 48,0</p>			

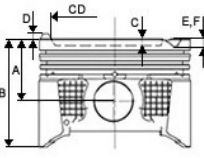











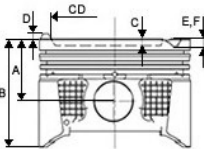
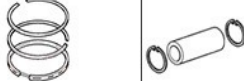



							
Motor /Engine	Ref. No. Kit 1	Ölçüler /Dimensions	Segman /Rings	Pim	Gömlek /Liner	Kit 2	Info
<p>ø72,50</p> <p>3 Cyl. Benzin, 973 cm³ 40 43 kW (54 58 PS) 10,1:1, 12 Ventile X10XE Z10XE <u>1996-2003</u></p> <p><i>Corsa Nova</i></p>	<p>17-3010190 STD 17-3010193 0.50</p>	<p>A = 24,000 B = 45,000 C = 1,200 E = -1,250 CD= 54,000</p>	<p>RE43360000 -STD RE43360050 -0.50</p> <p>1,200 (500) NitBSIF 1,500 (508) P 2,000 (700) NitS</p>	<p>ø18,0 x 50,9</p>			
<p>ø72,50</p> <p>4Cyl. Benzin 1199 cc 44 48 Kw (60 65 Ps) X12XE Z12XE <u>1997-2003</u></p> <p><i>Astra Corsa Agile</i></p>	<p>18-3010200 STD 18-3010203 0.50</p>	<p>A = 24,000 B = 45,000 E = -1,250</p>	<p>RE43360000 -STD RE43360050 -0.50</p> <p>1,200 (500) NitBSIF 1,500 (508) P 2,000 (700) NitS</p>	<p>ø18,0 x 50,9</p>			



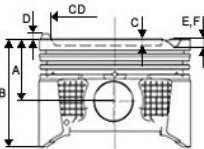







							
Motor /Engine	Ref. No. Kit 1	Ölçüler /Dimensions	Segman /Rings	Pim	Gömlek /Liner	Kit 2	Info
<p>ø73,40</p> <p>4 Cyl. Benzin 1229cc 63 kw/ 86 PS A12XER Euro 5 <u>2010 -</u></p> <p>Aveo II 1.2i 16V Corsa D 1.2i 16V</p>	<p>18-1010140 STD 18-1010143 0.50</p>	<p>A = 26,900 B = 48,550 D = 0,650 E = -1,350 F = -3,950 CD= 54,600</p> <p>Sert Anotlama (Hard Anodising)</p>	<p>RE43390000 -STD RE43390050 -0.50</p> <p>1,200 (500) NitBS 1,200 (508) P 2,000 (700) CrPS</p>	<p>ø18,0 x 52,3</p>			
<p>ø73,40</p> <p>4 Cyl. Benzin 1364 cc 74 Kw 101 PS A14XER <u>2009 - 2011</u></p> <p>Astra J 1.4i16V Aveo II 1.4i16V Corsa D 1.4i 16V Meriva B 1.4i16V</p>	<p>18-3010130 STD 18-3010133 0.50</p>	<p>A = 25,800 B = 46,800 C = 1,600 E = -1,900 F = -3,830 CD= 52,000</p> <p>Sert Anotlama (Hard Anodising)</p>	<p>RE43390000 -STD RE43390050 -0.50</p> <p>1,200 (500) NitBS 1,200 (508) P 2,000 (700) CrPS</p>	<p>ø18,0 x 52,3</p>			



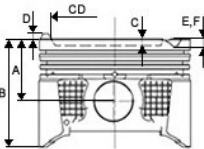







							
Motor /Engine	Ref. No. Kit 1	Ölçüler /Dimensions	Segman /Rings	Pim	Gömlek /Liner	Kit 2	Info
<p>ø73,40</p> <p>3 Cyl. Benzin, 998 cm³ 44 kW (60 PS) 10,5:1,12 Ventile Z10XEP 2003-2007</p> <p><i>Corsa Agile</i></p>	<p>17-3010140 STD 17-3010143 0.50</p>	<p>A = 24,000 B = 45,000 C = 0,820 E = -1,330 F = -1,350 CD= 52,000</p>	<p>RE43390000 -STD RE43390050 -0.50</p> <p>1,200 (500) NitBS 1,200 (508) P 2,000 (700) CrPS</p>	<p>ø18,0 x 50,9</p>			
<p>ø73,40</p> <p>4 Cyl. Benzin 1229 cc 59 KW (80 PS) Z12XEP 2004 -....</p> <p><i>Corsa C Agila Astra H Astra MK</i></p>	<p>18-3010150 STD 18-3010153 0.50</p>	<p>A = 24,000 B = 45,000 D = 0,530 E = -1,460 F = -1,490</p>	<p>RE43390000 -STD RE43390050 -0.50</p> <p>1,200 (500) NitBS 1,200 (508) P 2,000 (700) CrPS</p>	<p>ø18,0 x 50,9</p>			



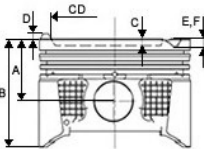



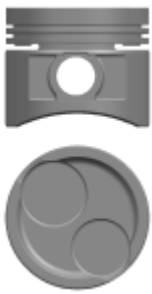

							
Motor /Engine	Ref. No. Kit 1	Ölçüler /Dimensions	Segman /Rings	Pim	Gömlek /Liner	Kit 2	Info
<p>ø73,40</p> <p>4 Cyl. Benzin 1364 cc 66 Kw (90 Ps) 10,5:1 Catal.Conv Z14XEP <u>2001 -....</u></p> <p>Astra 1.4 Corsa 1.4 Meriva 1.4</p>	<p>18-3010160 STD 18-3010163 0.50</p>	<p>A = 23,000 B = 44,000 C = 1,250 E = -1,330 F = -1,350 CD= 52,000</p>	<p>RE43390000 -STD RE43390050 -0.50</p> <p>1,200 (500) NitBS 1,200 (508) P 2,000 (700) CrPS</p>	<p>ø18,0 x 50,9</p>			
<p>ø74,00</p> <p>3 Cyl. Benzin 999 cc 66/77 KW 90/105 PS B10XFL Ecotec <u>2014 -..</u></p> <p>Astra Corsa Ascona Manta Kadett</p>	<p>17-3010060 STD 17-3010063 0.50</p>	<p>A = 27,500 B = 46,000 D = 2,500 E = -1,680 F = -2,810</p> <p>Sert Anotlama (Hard Anodising)</p>	<p>RE43640000 -STD RE43640050 -0.50</p> <p>1,200 () 1,200 () 2,000 ()</p>	<p>ø19,0 x 47,2</p>			



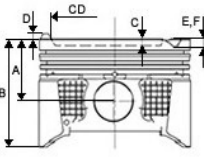









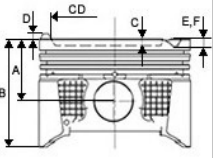





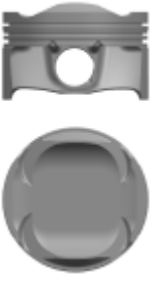

							
Motor /Engine	Ref. No. Kit 1	Ölçüler /Dimensions	Segman /Rings	Pim	Gömlek /Liner	Kit 2	Info
<p>ø74,00</p> <p>4 Cyl. Benzin 1399 cc 110 KW 150 HP B14XFT <u>2014 -.</u> Astra K</p>	<p>18-3010070 STD 18-3010073 0.50</p>	<p>A = 27,500 B = 46,000 D = 2,500 E = -1,680 F = -2,810</p> <p>Sert Anotlama (Hard Anodising)</p>	<p>RE43640000 -STD RE43640050 -0.50</p> <p>1,200 () 1,200 () 2,000 ()</p>	<p>ø19,0 x 47,2</p>			
<p>ø74,00</p> <p>4 Cyl. Benzin 1490 cc 121 KW 165 HP B15XFT Euro 6 <u>2017 -....</u> INSIGNIA MALIBU</p>	<p>18-3012460 STD 18-3012463 0.50</p>	<p>A = 28,000 B = 47,800 C = 4,800 D = 0,800 E = -3,460 F = -3,360 CD= 25,500</p> <p>Segman Taşıyıcı (Ring Carrier)</p>	<p>RE43640000 -STD RE43640050 -0.50</p> <p>1,200 () 1,200 () 2,000 ()</p>	<p>ø19,0 x 47,2</p>			



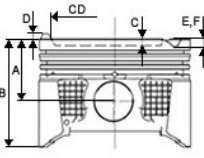







							
Motor /Engine	Ref. No. Kit 1	Ölçüler /Dimensions	Segman /Rings	Pim	Gömlek /Liner	Kit 2	Info
<p>ø75,00</p> <p>Cyl. Benzin 1297 cc 44 Kw (60 Ps) 9: Injection, Catal.Conv 1.3N 1.3NB 1.3S 1.3SB C1.3N <u>1986 - 1990</u></p> <p>Astra Corsa Ascona Manta Kadett</p>	<p>18-3010050 STD 18-3010053 0.50</p>	<p>A = 35,800 B = 62,400 C = 3,600 E = -5,400 CD= 63,500</p> <p>Sac Plaka (Steel Support)</p>	<p>RE43030000 -STD RE43030050 -0.50 RE43030100 -1.00</p> <p>1,500 (500) CrP 1,500 (501) P 4,000 (700) CrP</p>	<p>ø20,0 x 65,0</p>			
<p>ø75,00</p> <p>4 Cyl. Benzin 1297 cc 50 55 Kw (68 75 Ps) 1.3 S C1.3N <u>1986-1990</u></p> <p>Astra Corsa Ascona Manta Kadett</p>	<p>18-3010550 STD 18-3010553 0.50</p>	<p>A = 35,800 B = 62,400 C = 3,600 E = -4,750 CD= 63,000</p>	<p>RE43030000 -STD RE43030050 -0.50 RE43030100 -1.00</p> <p>1,500 (500) CrP 1,500 (501) P 4,000 (700) CrP</p>	<p>ø20,0 x 65,0</p>			

							
Motor /Engine	Ref. No. Kit 1	Ölçüler /Dimensions	Segman /Rings	Pim	Gömlek /Liner	Kit 2	Info
<p>ø75,00</p> <p>4 Cyl. Diesel 1568 cc 81/88 KW 110/120 PS DV6FDU DV6FC DV6FD B16DT B16DTH <u>2015 -....</u> <i>Crossland X Grandland X</i></p>	<p>18-3092330 STD 18-3092333 0.50</p>	<p>A = 41,700 B = 63,700 C = 13,150 CD= 45,500</p> <p>Segman Taşıyıcı (Ring Carrier)</p> <p>Yag Galerisi (Oil Gallery)</p> <p>Yag Püskürt. Oyugu (Oil Cut-Out)</p>	<p>RE43560000 -STD RE43560050 -0.50</p> <p>2,000 (503) Cr P 1,950 (508) P 2,000 (604) Cr P</p>	<p>ø26,0 x 58,0</p>			
<p>ø75,00</p> <p>3 Cyl. Benzin. 1199cc 50/55/60/61kW 68/75/82/83 PS 1.2 l HMM EB2FAD HMP EB2FB HMX EB2 MHZEB2 D/F 12 XE EB2FA <u>2012 -....</u> <i>1,2 VTi (82 Hp) Euro 5-EB2 108 2008 208 308II-D 12 XE F 12 XE</i></p>	<p>17-7511280 STD 17-7511283 0.50</p>	<p>A = 26,500 B = 45,000 C = 5,300</p> <p>Sert Anotlama (Hard Anodising)</p>	<p>RE18520000 -STD RE18520050 -0.50</p> <p>1,000 (910) NIT SY 1,000 (931) FE S 2,000 (947) EX NIT S</p>	<p>ø17,0 x 51,0</p>			

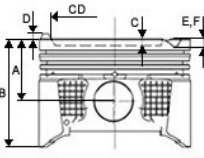









Motor /Engine	Ref. No. Kit 1	Ölçüler /Dimensions	Segman /Rings	Pim	Gömlek /Liner	Kit 2	Info
       							
ø75,00 3 Cyl. Benzin. 1199 cc 81/96kW 110/130/131 EB2DTS EB2DT 1.2 12V e THP 110/130 <u>2013/01 -....</u> 208 I (CA, CC) 308 II (SV II) 2008 (CU) 3008 MPV (OU) /SUV (M) 5008 (OU, OE) II PARTNER Tepee	17-7511290 STD 17-7511293 0.50	A = 28,450 B = 50,000 D = 4,700 E = -4,200 F = -3,300 Sert Anotlama (Hard Anodising)	RE47660000 -STD RE47660050 -0.50 1,200 () 1,000 () 2,000 ()	ø19,5 x 45,0			
							
ø76,00 4 Cyl. 1488 cc 37 kw 50 hp 4EC1 <u>1985-2000</u> Corsa Kadett	18-3050210 STD 18-3050213 0.50	A = 41,700 B = 71,700 C = 1,600 E = -0,350 Segman Taşıyıcı (Ring Carrier)	RE43040000 -STD RE43040050 -0.50 2,000 (500) CrP 1,500 (501) P 3,000 (604) CrP	ø22,0 x 60,0			
							

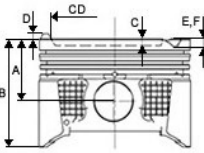





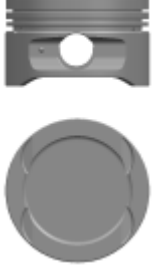

							
Motor /Engine	Ref. No. Kit 1	Ölçüler /Dimensions	Segman /Rings	Pim	Gömlek /Liner	Kit 2	Info
<p>ø76,00</p> <p>4 Cyl. Diesel, 1488 cm³ 49 kW (67 hp), 22,5:1 15TD <u>1988 -....</u> <i>Corça Kadett</i></p>	<p>18-3050220 STD 18-3050223 0.50</p>	<p>A = 41,700 B = 71,700 C = 1,600 E = -0,350</p> <p>Segman Taşıyıcı (Ring Carrier)</p>	<p>RE43040000 -STD RE43040050 -0.50</p> <p>2,000 (500) CrP 1,500 (501) P 3,000 (604) CrP</p>	<p>ø25,0 x 60,0</p>			
<p>ø77,60</p> <p>4 Cyl. Benzin 1389 cc 66 Kw (90 Ps) Z1.4XE GLHB <u>1999 -....</u> <i>Astra 1.4 Corça 1.4 E16 SE16V C16 SE ENJ/KAT</i></p>	<p>18-3010300 STD 18-3010303 0.50</p>	<p>A = 31,300 B = 55,750 D = 2,450</p>	<p>RE43480000 -STD RE43480050 -0.50 RE43480100 -1.00</p> <p>1,200 (500) NitB S 1,500 (501) P 2,000 (700) Cr P S</p>	<p>ø18,0 x 55,0</p>			



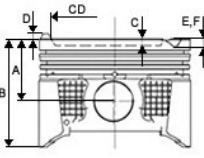





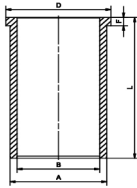



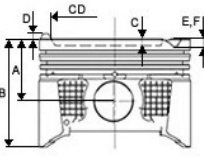





							
Motor /Engine	Ref. No. Kit 1	Ölçüler /Dimensions	Segman /Rings	Pim	Gömlek /Liner	Kit 2	Info
<p>ø77,60</p> <p>4 Cyl. Benzin 1396 cc 44 Kw (60 Ps) 9,4:1 C14NZ Z14NZ 14NV <u>1991-....</u></p> <p>Astra Corsa Ascona Kadett</p>	<p>18-3010650 STD 18-3010653 0.50</p>	<p>A = 32,050 B = 52,500 C = 3,300</p>	<p>RE43050000 -STD RE43050050 -0.50</p> <p>1,500 (500) CrP 1,500 (501) P 3,000 (700) CrP</p>	<p>ø18,0 x 55,0</p>			
<p>ø77,60</p> <p>4 Cyl. Benzin 1389 cc 66 Kw (90 Ps) 10,5:116 v Injection, Catal.Conv X14XE <u>1994-2000</u></p> <p>Astra 1,4i 16v Corsa CDX 1,4i 16v Tigra 1,4i 16v</p>	<p>18-3010770 STD 18-3010773 0.50</p>	<p>A = 32,050 B = 57,050 D = 0,300 E = -0,650</p> <p>Sac Plaka (Steel Support)</p>	<p>RE43050000 -STD RE43050050 -0.50</p> <p>1,500 (500) CrP 1,500 (501) P 3,000 (700) CrP</p>	<p>ø18,0 x 55,0</p>			



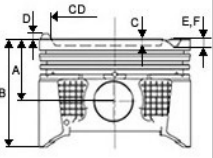





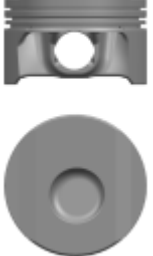
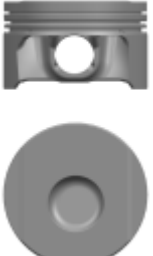



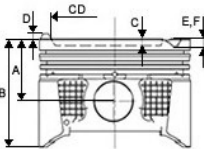





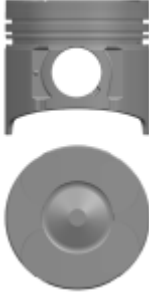
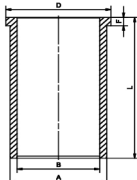

							
Motor /Engine	Ref. No. Kit 1	Ölçüler /Dimensions	Segman /Rings	Pim	Gömlek /Liner	Kit 2	Info
<p>ø79,00</p> <p>4Cyl. Benzin 1598 cc 74 78 Kw (101 106 Ps) 10,5:1 16v Injection Catal.Conv X16XE X16XEL <u>1991-1995</u></p> <p>Astra Corsa Tigra Zafira Vectra</p> 	<p>18-3010380 STD</p> <p>18-3010380-20 STD (-0.20 mm)</p> <p>18-3010383 0.50</p> <p>18-3010388 1.00</p>	<p>A = 28,000 B = 48,000 C = 0,800 E = -1,900 F = -2,150 CD= 60,200</p> <p>Sac Plaka (Steel Support)</p>	<p>RE43320000 -STD RE43320025 -0.25 RE43320050 -0.50 RE43320100 -1.00</p> <p>1,200 (500) CrB S 1,500 (508) P 2,500 (700) Cr P S</p>	<p>ø18,0 x 55,0</p>	<p>G82001300K_1</p> <p>A= 82,000 B= 78,300 D= 83,500 F= 5,000 H= 0,000 L= 130,000</p> 		
<p>ø79,00</p> <p>4Cyl. Benzin 1598 cc 74 Kw (101 Ps) Y16 XE Z16XE <u>2000 -.....</u></p> <p>Vectra 1.6i 16v Astra 1.6i Meriva 1.6i 16v Zafira 1.6i 16v</p> 	<p>18-3010390 STD</p> <p>18-3010390-20 STD (-0.20 mm)</p> <p>18-3010393 0.50</p> <p>18-3010393-20 0.50 (-0.20 mm)</p> <p>18-3010398 1.00</p> <p>18-3010398-20 1.00 (-0.20 mm)</p>	<p>A = 27,200 B = 50,200</p>	<p>RE43320000 -STD RE43320025 -0.25 RE43320050 -0.50 RE43320100 -1.00</p> <p>1,200 (500) CrB S 1,500 (508) P 2,500 (700) Cr P S</p>	<p>ø18,0 x 55,0</p>			

							
Motor /Engine	Ref. No. Kit 1	Ölçüler /Dimensions	Segman /Rings	Pim	Gömlek /Liner	Kit 2	Info
<p>ø79,00</p> <p>4 Cyl. Benzin 1598 cc 74 Kw (101 Ps) Z16XEP <u>2003 -....</u></p> <p>Meriva 1.6 Astra Twinport</p>	<p>18-3010400 STD 18-3010403 0.50 18-3010408 1.00</p>	<p>A = 26,730 B = 48,730</p>	<p>RE43490000 -STD RE43490050 -0.50 RE43490100 -1.00</p> <p>1,200 (500) NitB S 1,200 (501) P 2,000 (700) Cr P S</p>	<p>ø18,0 x 52,0</p>			
<p>ø79,00</p> <p>4 Cyl. Benzin 1598 cc 132KW (180/192 BG) GÜÇLENDİRİLMİŞ A 16 LET Z 16 LET <u>2008/2009 -</u></p> <p>Corsa D 1.6i Turbo 16V Astra H-J 1.6i 16V Insignia 1.6i Turbo 16V SAAB A 16 LTE VAUXHALL A/Z 16 LET WESTFIELD Z 16 LET</p>	<p>18-3010420 STD 18-3010423 0.50 18-3010428 1.00</p>	<p>A = 27,500 B = 45,100</p> <p>Segman Taşıyıcı (Ring Carrier)</p> <p>Sert Anotlama (Hard Anodising)</p>	<p>RE43490000 -STD RE43490050 -0.50 RE43490100 -1.00</p> <p>1,200 (500) NitB S 1,200 (501) P 2,000 (700) Cr P S</p>	<p>ø19,0 x 53,0</p>	<p>G82001250K_1</p> <p>A= 82,000 B= 78,300 D= 83,500 F= 5,000 H= 0,000 L= 125,000</p>		

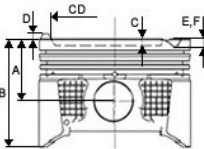





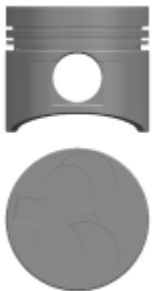
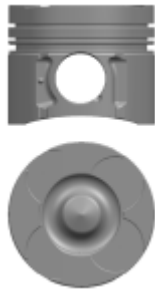

							
Motor /Engine	Ref. No. Kit 1	Ölçüler /Dimensions	Segman /Rings	Pim	Gömlek /Liner	Kit 2	Info
<p>ø79,00</p> <p>4 Cyl. Benzin, 1598 cm³ 55 75 kW (75 102 PS) 8,6:1 Enjekt C16NZ X16SZR E16NZ X16SZ GLBH 1.6 LZ <u>1987-1993</u></p> <p>Astra II 1.6 I Kat Corsa Kadett Vectra Ascona</p>	<p>18-3010480 STD 18-3010483 0.50</p>	<p>A = 28,000 B = 48,400 C = -2,700 D = 0,400 CD= 62,500</p>	<p>RE43090000 -STD RE43090025 -0.25 RE43090050 -0.50 RE43090100 -1.00</p> <p>1,200 (500) CrB S 1,500 (508) P 3,000 (700) Cr S P</p>	<p>ø18,0 x 55,0</p>			
<p>ø79,00</p> <p>4 Cyl. Benzin, 1598 cm³ 60 66 kW (82 90 PS) C16SE E16SE 16SV</p> <p>Astra Corsa Kadett Vectra</p>	<p>18-3010580 STD 18-3010581 0.25 18-3010583 0.50 18-3010588 1.00</p>	<p>A = 28,000 B = 48,400 C = 1,600 D = 0,400 CD= 59,000</p>	<p>RE43090000 -STD RE43090025 -0.25 RE43090050 -0.50 RE43090100 -1.00</p> <p>1,200 (500) CrB S 1,500 (508) P 3,000 (700) Cr S P</p>	<p>ø18,0 x 55,0</p>			



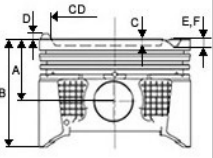





Motor /Engine	Ref. No. Kit 1	Ölçüler /Dimensions	Segman /Rings	Pim	Gömlek /Liner	Kit 2	Info
       							
ø79,00 4 Cyl. Benzin 1598 cc 125kW 170HP GÜÇLENDİRİLMİŞ A 16 XHT B 16 SHL 1.6 <u>2014 - 2017</u> Insignia A Country Tourer (G09) 1.6 SIDI (47) Otto Station Wagon	18-3012440 STD 18-3012443 0.50	A = 29,000 B = 50,200 C = 7,000 D = 2,200 CD= 30,200 Segman Taşıyıcı (Ring Carrier)	RE43490000 -STD RE43490050 -0.50 RE43490100 -1.00 1,200 (500) NitB S 1,200 (501) P 2,000 (700) Cr P S	ø21,0 x 51,0			
							
ø79,00 4 Cyl. Benzin 1598 cc 125kW 170HP GÜÇLENDİRİLMİŞ B16SHT <u>2014 - 2017</u> Insignia A Country Tourer (G09) 1.6 SIDI (47) Otto Station Wagon	18-3012450 STD 18-3012453 0.50	A = 29,000 B = 48,700 C = 7,000 D = 0,700 CD= 30,200 Segman Taşıyıcı (Ring Carrier)	RE43490000 -STD RE43490050 -0.50 RE43490100 -1.00 1,200 (500) NitB S 1,200 (501) P 2,000 (700) Cr P S	ø21,0 x 51,0			
							



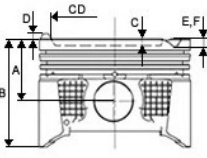



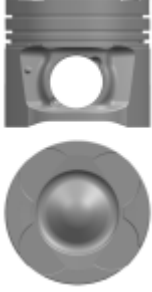

							
Motor /Engine	Ref. No. Kit 1	Ölçüler /Dimensions	Segman /Rings	Pim	Gömlek /Liner	Kit 2	Info
<p>ø79,00</p> <p>4 Cyl. Diesel 1686 cc 55 Kw (75 Ps) 18,4:1 Turbo, Intercooler Y17DT/DTL</p> <p><u>2002-2005</u></p> <p>Astra G Combo Box Corsa C Meriva</p>	<p>18-3050260 STD 18-3050260-20 STD (-0.20 mm)</p> <p>18-3050263 0.50 18-3050263-20 0.50 (-0.20 mm)</p> <p>18-3050268 1.00 18-3050268-20 1.00 (-0.20 mm)</p> 	<p>A = 39,740 B = 84,000 C = 14,000 E = -1,100 CD= 38,700</p> <p>Segman Taşıyıcı (Ring Carrier)</p> <p>Yag Püskürt. Oyugu (Oil Cut-Out)</p>	<p>RE43100000 -STD RE43100025 -0.25 RE43100050 -0.50 RE43100100 -1.00</p> <p>2,000 (500) Cr 1,500 (501) P 3,000 (604) Cr P</p>	<p>ø27,0 x 64,0</p>	<p>G82001370K_1</p> <p>A= 82,000 B= 78,300 D= 83,500 F= 5,000 H= 0,000 L= 137,000</p> 		<p>1,45 mm conta +0,63 +0,70</p> <p>1,50 mm conta +0,70 +0,76</p> <p>1,55 mm conta 0,76 0,83</p>
<p>ø79,00</p> <p>4 Cyl. Diesel, 1689 cm³ 59 kW (80 PS) 18,4:1,16 Ventile Z17DTL</p> <p><u>2003-2009</u></p> <p>Astra G Combo Box Corsa C Meriva</p>	<p>18-3050270 STD 18-3050270-20 STD (-0.20 mm)</p> <p>18-3050273 0.50 18-3050273-20 0.50 (-0.20 mm)</p> 	<p>A = 39,740 B = 84,000 C = 14,000 CD= 41,800</p> <p>Segman Taşıyıcı (Ring Carrier)</p>	<p>RE43100000 -STD RE43100025 -0.25 RE43100050 -0.50 RE43100100 -1.00</p> <p>2,000 (500) Cr 1,500 (501) P 3,000 (604) Cr P</p>	<p>ø27,0 x 64,0</p>			



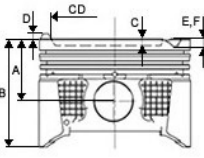





							
Motor /Engine	Ref. No. Kit 1	Ölçüler /Dimensions	Segman /Rings	Pim	Gömlek /Liner	Kit 2	Info
<p>ø79,00</p> <p>4 Cyl. Diesel, 1689 cm³ 74 kW (100 PS) 18,4:1,16 Ventile Z17DTH</p> <p>Astra-H 1. CDTI 03/2004-02/2007 Combo 1.7 CDTI 12/2004- Corsa-C 1.7 CDTI 06/2003-08/2003 Meriva 1.7 CDTI 09/2003-05/2010</p>	<p>18-3050280 STD</p> <p>18-3050280-20 STD (-0.20 mm)</p> <p>18-3050281 0.25</p> <p>18-3050283 0.50</p> <p>18-3050283-20 0.50 (-0.20 mm)</p> <p>18-3050288 1.00</p>	<p>A = 39,750 B = 64,750 C = 14,100 E = -1,300 F = -1,200 CD= 41,800</p> <p>Segman Taşıyıcı (Ring Carrier)</p> <p>Yag Galerisi (Oil Gallery)</p>	<p>RE43100000 -STD RE43100025 -0.25 RE43100050 -0.50 RE43100100 -1.00</p> <p>2,000 (500) Cr 1,500 (501) P 3,000 (604) Cr P</p>	<p>ø27,0 x 64,0</p>			
<p>ø79,00</p> <p>4 Cyl. Diesel, 1686 cm³ 44 65 kW (60 88 PS) 22:1, 8 Ventile 17D(4EE1) TC4EE 1 X 17D(4EE1) <u>1991-2006</u></p> <p>Corsa B 1,7 D Combo 1,7 D ASTRA-F 1.7 TDS</p>	<p>18-3050940 STD</p> <p>18-3050943 0.50</p>	<p>A = 39,700 B = 69,600 C = 1,900 E = -1,200</p> <p>Segman Taşıyıcı (Ring Carrier)</p>	<p>RE43100000 -STD RE43100025 -0.25 RE43100050 -0.50 RE43100100 -1.00</p> <p>2,000 (500) Cr 1,500 (501) P 3,000 (604) Cr P</p>	<p>ø27,0 x 64,0</p>			



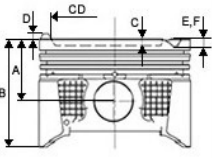





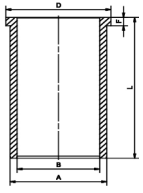



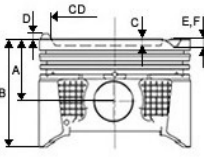







Motor /Engine	Ref. No. Kit 1	Ölçüler /Dimensions	Segman /Rings	Pim	Gömlek /Liner	Kit 2	Info
							
ø79,00 4Cyl. Diesel 1686 cc 44/60 Kw (60/82 Ps) Turbo XATD 1.7TD 1998 -.... Corsa 1,7 D Combo 1,7	18-3050950 STD 18-3050950-20 STD (-0.20 mm) 18-3050953 0.50 18-3050953-20 0.50 (-0.20 mm) 18-3050958 1.00 18-3050958-20 1.00 (-0.20 mm)	A = 39,700 B = 79,800 C = 1,200 E = -0,500 F = -0,500 Segman Taşıyıcı (Ring Carrier) Sac Plaka (Steel Support)	RE43100000 -STD RE43100025 -0.25 RE43100050 -0.50 RE43100100 -1.00 2,000 (500) Cr 1,500 (501) P 3,000 (604) Cr P	ø25,0 x 60,0			
ø79,01 4 Cyl. Benzin 1600cc 120 BG Z16XER A16XER 1.6 CRUZE OEM2510255 2009 -.... Astra H Astra J Insignia 1.6 Cruze 1.6	18-3010410 STD 18-3010413 0.50 18-3010418 1.00	A = 26,700 B = 48,700 D = 1,200 E = -1,900 F = -2,700 CD= 52,960 Sert Anotlama (Hard Anodising)	RE43490000 -STD RE43490050 -0.50 RE43490100 -1.00 1,200 (500) NitB S 1,200 (501) P 2,000 (700) Cr P S	ø19,0 x 46,0			



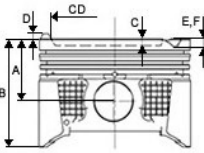





							
Motor /Engine	Ref. No. Kit 1	Ölçüler /Dimensions	Segman /Rings	Pim	Gömlek /Liner	Kit 2	Info
<p>ø79,70</p> <p>4 Cyl. Diesel 1598 cc 100 Kw (136 Ps) B16DTH Euro 6 Ecotec</p> <p><u>2013 -.</u></p> <p>Astra Vectra</p>	<p>18-3092310 STD 18-3092313 0.50</p>	<p>A = 45,800 B = 70,800 C = 13,500 E = -1,100 F = -1,000 CD= 45,000</p> <p>Segman Taşıyıcı (Ring Carrier)</p> <p>Yag Galerisi (Oil Gallery)</p> <p>Yag Püskürt. Oyugu (Oil Cut-Out)</p> 	<p>RE43610000 -STD RE43610050 -0.50</p> <p>1,500 (xxx) Cr 1,500 (xxx) P 2,000 (xxx)</p>	<p>ø29,0 x 63,0</p>			
<p>ø79,70</p> <p>4 Cyl. Diesel 1598 cc 110 Ps B16DTL Euro 6 Ecotec</p> <p><u>2013 -.</u></p> <p>Astra Zafir</p>	<p>18-3092320 STD 18-3092323 0.50</p>	<p>A = 40,800 B = 65,800 C = 13,500 E = -1,100 F = -1,000 CD= 45,000</p> <p>Segman Taşıyıcı (Ring Carrier)</p> <p>Yag Galerisi (Oil Gallery)</p> <p>Yag Püskürt. Oyugu (Oil Cut-Out)</p>	<p>RE43610000 -STD RE43610050 -0.50</p> <p>1,500 (xxx) Cr 1,500 (xxx) P 2,000 (xxx)</p>	<p>ø25,0 x 58,2</p>			



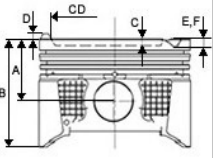





							
Motor /Engine	Ref. No. Kit 1	Ölçüler /Dimensions	Segman /Rings	Pim	Gömlek /Liner	Kit 2	Info
<p>ø80,00</p> <p>4. Cyl. Benzincc</p> <p>1.6 LZ 1.6 LZ 2</p> <p><u>1994 - 2001</u></p> <p>1.6 LZ VECTRA A (94..95) 1.6 LZ 2 VECTRA B (96..2001)</p>	<p>18-3010670 STD 18-3010673 0.50</p>	<p>A = 33,650 B = 57,650 C = 2,900 CD= 58,000</p>	<p>RE43570000 -STD RE43570050 -0.50</p> <p>1,500 () Cr 1,500 () 2,000 () Cr</p>	<p>ø21,0 x 53,0</p>			
<p>ø80,00</p> <p>4 Cyl. Diesel 1598 cc 40 Kw (54 Ps) 22,5:1 16 D 16 DA</p> <p><u>1982-1989</u></p> <p>Astra G Combo Box Corsa C Meriva</p>	<p>18-3050900 STD 18-3050903 0.50 18-3050908 1.00</p>	<p>A = 44,950 B = 76,950 C = 1,500</p> <p>Segman Taşıyıcı (Ring Carrier)</p> <p>Sert Anotlama (Hard Anodising)</p> <p>Sac Plaka (Steel Support)</p>	<p>RE43110000 -STD RE43110050 -0.50 RE43110100 -1.00</p> <p>2,000 (500) Cr B S 2,000 (501) P 3,000 (604) Cr P</p>	<p>ø26,0 x 65,0</p>			<p>1,30 mm conta 0 +0,75</p> <p>1,40 mm conta +0,75 +0,85</p> <p>1,50 mm conta +0,85 +1,05</p>



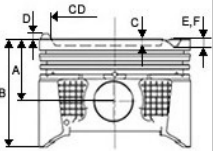





Motor /Engine	Ref. No. Kit 1	Ölçüler /Dimensions	Segman /Rings	Pim	Gömlek /Liner	Kit 2	Info
       							
ø80,00 4/6 Cyl. Diesel 1669/2498 cc 105 Kw (90/143 Ps) M41/M51 D25WA/BMW 25 6T X 25 DT/TD 25 LT 1990 -.... Turbo Intercooler 318 Compact TDS/TouringSE 325 325/525 TDS/Touring 725 TDS Omega TDS Range Rover	17-6592090 STD 17-6592093 0.50	A = 39,450 B = 62,450 C = 2,500 Segman Taşıyıcı (Ring Carrier) Yag Galerisi (Oil Gallery) Sac Plaka (Steel Support) Yag Püskürt. Oyugu (Oil Cut-Out)	RE15140000 -STD RE15140050 -0.50 RE15140100 -1.00 3,000 (504) Cr 1,750 (501) P IFU 3,000 (604) Cr	ø27,0 x 63,0			
ø80,00 4 Cyl. Diesel 1870 cc 74 Kw (100Ps)18.3: Turbo, Intercooler F9Q. Turbo Intercooler 2000 -... Kangoo 1.9 Tdi Megane 1.9 Tdi Laguna 1.9 Tdi Scenic 1.9 Tdi Traffic 1.9 Tdi Carisma 1.9 GDI Vivaro 1,9 CDTI 8 v	18-8050940 STD 18-8050943 0.50	A = 47,060 B = 77,000 C = 17,800 E = -0,750 CD= 38,000 Segman Taşıyıcı (Ring Carrier) Yag Püskürt. Oyugu (Oil Cut-Out)	RE49380000 -STD RE49380050 -0.50 2,500 (500) CKP 2,000 (501) P 3,000 (604) Cr	ø28,0 x 60,0	G80001550K_1 A= 83,000 B= 79,300 D= 85,000 F= 5,000 H= 0,000 L= 155,000 	+0,60 +0,80	



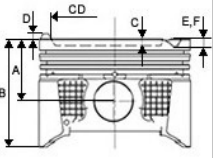





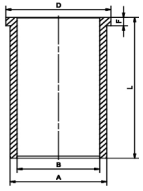

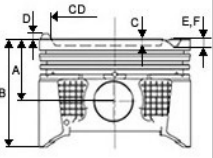

							
Motor /Engine	Ref. No. Kit 1	Ölçüler /Dimensions	Segman /Rings	Pim	Gömlek /Liner	Kit 2	Info
<p>ø80,50</p> <p>4 Cyl. Benzin, 1796 cm³ 79 92 kW (107 125 PS) X18XE1 Z18XE Z18ZEL <u>1998-2005</u></p> <p>Astra Zafira Vectra Corsa Meriva Tigra</p>	<p>18-3010800 STD 18-3010803 0.50 18-3010808 1.00</p> 	<p>A = 24,100 B = 44,700</p>	<p>RE43370000 -STD RE43370050 -0.50 RE43370100 -1.00</p> <p>1,200 (500) NitB S IF 1,200 (508) P 2,000 (700) Nit S</p>	<p>ø18,0 x 55,0</p>			
<p>ø80,50</p> <p>4 Cyl. Benzin, 1796 cm³ 85 kW (115 hp) Z18XER <u>2000-.....</u></p> <p>Astra H 1.8i 16V Zafira B 1.8i 16V Vectra C 1.8i 16V Signum 1.8i 16V</p>	<p>18-3010830 STD 18-3010833 0.50 18-3010838 1.00</p> 	<p>A = 26,100 B = 45,100 D = 0,700</p> <p>Sert Anotlama (Hard Anodising)</p>	<p>RE43370000 -STD RE43370050 -0.50 RE43370100 -1.00</p> <p>1,200 (500) NitB S IF 1,200 (508) P 2,000 (700) Nit S</p>	<p>ø19,0 x 50,0</p>			









							
Motor /Engine	Ref. No. Kit 1	Ölçüler /Dimensions	Segman /Rings	Pim	Gömlek /Liner	Kit 2	Info
<p>ø81,60</p> <p>4 Cyl. Benzin, 1796 cm³ 92 kW (125 hp) C18XE C18XEL <u>1993-2000</u> Astra F Vectra B</p>	<p>18-3010790 STD 18-3010793 0.50</p>	<p>A = 30,400 B = 50,400 C = 1,840 E = -1,790 CD= 50,800</p>	<p>RE43140000 -STD RE43140050 -0.50 RE43140100 -1.00</p> <p>1,500 (500) CrB S IF 1,500 (508) P 3,000 (700) Cr P S</p>	<p>ø21,0 x 61,5</p>			
<p>ø81,60</p> <p>6 Cyl. Benzin 2498 cc 125 Kw (170 Ps) C2.5XE X2.5XE <u>1993 -....</u> Omega B 2,5 24v Vectra B 2,5 24v Calibra 2,5l 24v Carlton 2,5l</p>	<p>17-3010810 STD 17-3010813 0.50</p>	<p>A = 30,450 B = 50,400 D = 0,630 E = -2,000</p>	<p>RE43140000 -STD RE43140050 -0.50 RE43140100 -1.00</p> <p>1,500 (500) CrB S IF 1,500 (508) P 3,000 (700) Cr P S</p>	<p>ø21,0 x 56,0</p>			



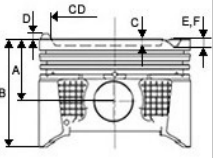





Motor /Engine	Ref. No. Kit 1	Ölçüler /Dimensions	Segman /Rings	Pim	Gömlek /Liner	Kit 2	Info
       							
ø82,00 4 Cyl. Diesel 1910 cc 77 Kw (103 Ps) Z19DT 182B.9000 <u>2001 -....</u> Doblo 1.9 JTD	18-3051940 STD 18-3051942 0.40 18-3051947 0.80	A = 46,500 B = 72,500 C = 17,450 E = -0,650 CD= 37,550 Segman Taşıyıcı (Ring Carrier) Burc (Bushing)	RE22730000 -STD RE22730040 -0.40 RE22730060 -0.60 RE22730080 -0.80 RE22730100 -1.00 2,000 (500) Cr P 2,000 (508) P 2,000 (604) Cr P	ø26,0 x 61,0			0,77 0,87mm conta +0,014 +0,104 0,87 0,97mm conta +0,105 +0,205 0,97 1,07mm conta +0,236 +0,294
ø82,00 4 Cyl. Diesel 1900 cc 110 Kw 1/9 JTD Euro 4 16 V <u>2000 -....</u> Astra Zafira Vectra&Signum Signum Vectra Zafira Doblo 1.9 JTD Bravo 1.9 JTD Stilo 1.9 JTD	18-3083440 STD 18-3083442 0.40	A = 46,500 B = 72,500 C = 15,400 E = -1,070 F = -1,020 CD= 41,500 Segman Taşıyıcı (Ring Carrier) Yag Galerisi (Oil Gallery)	RE22730000 -STD RE22730040 -0.40 RE22730060 -0.60 RE22730080 -0.80 RE22730100 -1.00 2,000 (500) Cr P 2,000 (508) P 2,000 (604) Cr P	ø30,0 x 67,0			



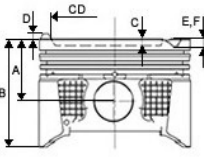



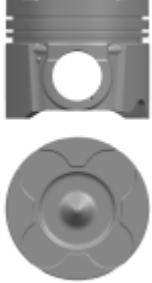

Motor /Engine	Ref. No. Kit 1	Ölçüler /Dimensions	Segman /Rings	Pim	Gömlek /Liner	Kit 2	Info
       							
ø82,50 4 Cyl. Diesel, 1699 cm ³ 50 kW (68 PS), 22:1 Turbo, LLK, 8 Ventile X17DTL X17DTL <u>1994-2006</u> ASTRA-F 1.7 TD ASTRA-G 1.7 TD ASTRAVAN III 1.7 TD	18-3050920 STD 18-3050923 0.50 18-3050928 1.00	A = 68,816 B = 72,950 C = 1,600 Sert Anotlama (Hard Anodising) Sac Plaka (Steel Support)	RE43150000 -STD RE43150050 -0.50 RE43150100 -1.00 2,000 (500) Cr 2,000 (501) P 3,000 (604) Cr	ø26,0 x 65,0			
ø82,50 4 Cyl. Diesel 1700 cc 42 Kw (57 Ps) 23:1 17D 17DR <u>1988-1995</u> ASTRA-F 1.7 D ASTRAVAN III 1.7 D KADETT-E 1.7 D VECTRA-A 1.7 D COMBO 1,7 D,	18-3050960 STD 18-3050963 0.50 18-3050968 1.00	A = 44,950 B = 72,950 C = 0,350 Segman Taşıyıcı (Ring Carrier) Sert Anotlama (Hard Anodising) Sac Plaka (Steel Support)	RE43150000 -STD RE43150050 -0.50 RE43150100 -1.00 2,000 (500) Cr 2,000 (501) P 3,000 (604) Cr	ø26,0 x 65,0			1.30 mm conta 0 +0,75 1.40 mm conta +0,75 +0,85 1.50 mm conta +0,85 +1,05



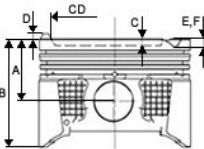





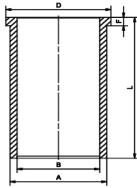

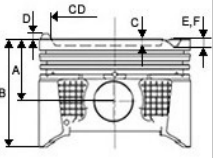

Motor /Engine	Ref. No. Kit 1	Ölçüler /Dimensions	Segman /Rings	Pim	Gömlek /Liner	Kit 2	Info
							
ø83,00 4 Cyl. Diesel 1991cc 110 Kw(150 BG) Z20S Z20DMH 2006 - CAPTIVA 2.0 16V D ANTARA 2.0 CDTI 16V	18-1092500 STD 18-1092503 0.50	A = 46,350 B = 72,350 C = 13,950 CD= 46,700 Segman Taşıyıcı (Ring Carrier) Yag Galerisi (Oil Gallery)	RE43460000 -STD RE43460000_NPR -STD RE43460050 -0.50 2,000 (505) Nit S 2,000 (501) P 3,000 (604) Nit S	ø28,0 x 66,8			1 kertik 0.11 0.23 2 kertik 0.24 0.33 3 kertik 0.34 0.42
ø83,00 4 Cyl. Diesel 1956 cc 81 125 KW 116 170Ps 16,5:1 198 A5.000 A/Y/Z 20DT/C/H/J/L 939B 5.000/940A 5.000 A5 198/940 2008 - Freemont Astra J Insignia 2.0 CDTI 16V Zafira MK III 2.0 CDTI Doblo 2.0 JTD Alfa Romeo Chrysler Lancia Saab Vauxhall Holden	18-2092650 STD 18-2092653 0.50	A = 46,630 B = 72,630 C = 15,800 E = -1,171 F = -1,220 CD= 43,500 Segman Taşıyıcı (Ring Carrier) Yag Galerisi (Oil Gallery)	RE43510000 -STD RE43510040 -0.40 RE43510050 -0.50 1,500 (500) Cr P 1,500 (508) P 2,000 (604) Nit S	ø30,0 x 67,0	G86001550K_1 A= 86,000 B= 82,300 D= 87,500 F= 5,000 H= 0,000 L= 155,000		









Motor /Engine	Ref. No. Kit 1	Ölçüler /Dimensions	Segman /Rings	Pim	Gömlek /Liner	Kit 2	Info
       							
ø83,00 4 Cyl. Diesel 1956 cc 125 KW 170 PS B 20 DTH Euro 6 <u>2014 -....</u> Astra J Insignia A-B Zafira Tourer Cı	18-3092340 STD 18-3092343 0.50	A = 46,600 B = 72,800 C = 14,370 E = -1,670 F = -1,790 CD= 48,500 Segman Taşıyıcı (Ring Carrier) Yag Galerisi (Oil Gallery)	RE43510000 -STD RE43510040 -0.40 RE43510050 -0.50 1,500 (500) Cr P 1,500 (508) P 2,000 (604) Nit S	ø30,0 x 65,0			
 							
ø84,00 4 Cyl. Diesel 1998 cc 60 Kw (82 Ps) 18,7:1 Turbo, Intercooler 24v X20DTL Y20DTL <u>1996-2004</u> Astra F 16v Astra G 16v Omega B 26v Vectra B 16v	18-3050970 STD 18-3050973 0.50	A = 45,800 B = 70,800 C = 14,840 E = -1,000 CD= 41,000 Segman Taşıyıcı (Ring Carrier)	RE43330000 -STD RE43330050 -0.50 2,000 (500) CrB S 1,750 (508) P 3,000 (604) Nit S	ø29,0 x 68,0			STD Conta +0,40 + 0,50 1çentikconta +0,51 +0,60 2çentikconta +0,61 +0,70
 							



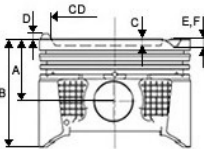



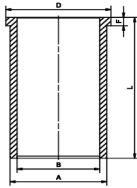

Motor /Engine	Ref. No. Kit 1	Ölçüler /Dimensions	Segman /Rings	Pim	Gömlek /Liner	Kit 2	Info
       							
ø84,00 4 Cyl. Diesel 1998 cc 74 Kw (100 Ps) 19,5:1 Turbo, Intercooler 24 v X20DTH <u>1997-2004</u> Zafira 16v Astra G 16v Omega B 16v Vectra B 16v	18-3050980 STD 18-3050983 0.50	A = 45,800 B = 70,800 C = 14,610 E = -1,000 CD= 41,000 Segman Taşıyıcı (Ring Carrier) Yag Püskürt. Oyugu (Oil Cut-Out)	RE43340000 -STD RE43340050 -0.50 2,500 (505) Cr P 1,750 (508) P 3,000 (604) Nit S	ø29,0 x 68,0			STD Conta +0,40 +0,50 1çentik conta +0,51 +0,60 2çentik conta +0,61 +0,70
ø84,00 4 Cyl. Diesel 1995 cc Y 20 DTH <u>2002 - 2011</u> Astra 2.0 DTI Astra 2.0 DTI gls	18-3092910 STD 18-3092913 0.50	A = 45,800 B = 70,800 C = 14,670 E = -1,050 CD= 41,000 Segman Taşıyıcı (Ring Carrier) Yag Galerisi (Oil Gallery) Yag Püskürt. Oyugu (Oil Cut-Out)	RE43350000 -STD RE43350050 -0.50 RE43350100 -1.00 1,750 (500) Cr P 1,750 (501) P 3,000 (604) Cr P	ø29,0 x 68,0			



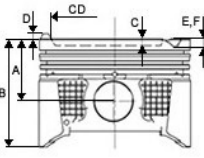





							
Motor /Engine	Ref. No. Kit 1	Ölçüler /Dimensions	Segman /Rings	Pim	Gömlek /Liner	Kit 2	Info
<p>ø84,00</p> <p>4 Cyl. Diesel 2172 cc 81/85/86/88/92 kW 110/116/117/120/125 PS X22DTH Y22DTH Y22DTR</p> <p>.... -</p> <p><i>Frontera B 2.2 DTI Sintra 2.2 DTI Omega B 2.2 DTI 16V Astra G 2.2 DTI Signum 2.2 DTI/16V Vectra B/C/C GTS 2.2 DTI Zafira A 2.2 DTI 16V</i></p>	<p>18-3092930 STD 18-3092933 0.50</p>	<p>A = 45,800 B = 70,800 C = 14,670 E = -1,050 CD= 43,000</p> <p>Segman Taşıyıcı (Ring Carrier)</p> <p>Yag Galerisi (Oil Gallery)</p> <p>Yag Püskürt. Oyugu (Oil Cut-Out)</p>	<p>RE43350000 -STD RE43350050 -0.50 RE43350100 -1.00</p> <p>1,750 (500) Cr P 1,750 (501) P 3,000 (604) Cr P</p>	<p>ø29,0 x 68,0</p>			
<p>ø84,00</p> <p>4 Cyl. Diesel 1995 cc 74 Kw (101 Ps) 18,5:1 Turbo, Intercooler 24 v Y20DTH</p> <p>08/2002 -</p> <p><i>ASTRA 2.0 DTI GLS ASTRA 2.0 DTI ASTRA-G 2.0 DI ASTRAVAN IV 2.0 DTI SIGNUM 2.0 DTI VECTRA I/II 2. DTI ZAFIRA I 2.0 DTI</i></p>	<p>18-3092990 STD 18-3092993 0.50</p>	<p>A = 45,800 B = 70,800 C = 14,900 E = -1,000 CD= 41,000</p>	<p>RE43350000 -STD RE43350050 -0.50 RE43350100 -1.00</p> <p>1,750 (500) Cr P 1,750 (501) P 3,000 (604) Cr P</p>	<p>ø29,0 x 62,0</p>			



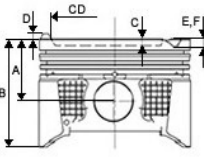



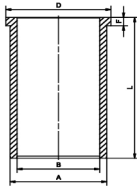

							
Motor /Engine	Ref. No. Kit 1	Ölçüler /Dimensions	Segman /Rings	Pim	Gömlek /Liner	Kit 2	Info
<p>ø84,80</p> <p>4 Cyl. Benzin, 1796 cm³ 60 74 kW (82 101 PS) 1.8S <u>1986-1988</u></p> <p>Astra Corça Kadett Vectra</p>	<p>18-3010490 STD 18-3010493 0.50</p>	<p>A = 33,650 B = 53,650 C = 5,000 CD= 52,000</p>	<p>RE43160000 -STD RE43160050 -0.50 RE43160100 -1.00</p> <p>1,500 (500) CrB S IF 1,500 (508) P 3,000 (700) Cr S P</p>	<p>ø21,0 x 61,5</p>			
<p>ø84,80</p> <p>4 Cyl. Benzin, 1796 cm³ 63 85 kW (86 115 PS) 18E 18SV <u>1982-1994</u></p> <p>Astra Kadett Omega Vectra</p>	<p>18-3010590 STD 18-3010593 0.50</p>	<p>A = 33,650 B = 53,650 C = 4,000 CD= 41,000</p>	<p>RE43160000 -STD RE43160050 -0.50 RE43160100 -1.00</p> <p>1,500 (500) CrB S IF 1,500 (508) P 3,000 (700) Cr S P</p>	<p>ø21,0 x 61,5</p>	<p>G88001390K_1</p> <p>A= 88,000 B= 84,100 D= 89,500 F= 5,000 H= 0,000 L= 139,000</p>		



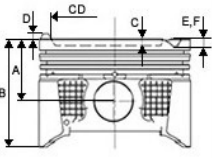



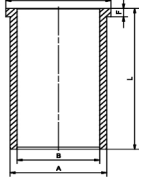
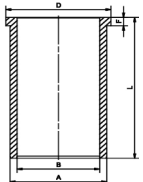

Motor /Engine	Ref. No. Kit 1	Ölçüler /Dimensions	Segman /Rings	Pim	Gömlek /Liner	Kit 2	Info
       							
ø85,00 4 Cyl. Diesel 1997 cc 81/88/100/110 130/132133 KW 110/120/136/150 179/181 PS AHH/J/M/NP/T/U/X EHS/T/W/Y/Z D20 DTH/L/R DW10FC/E/UE/UD/CD FDCC/CU/DDU Euro 5 2009 - 5008/508/508 SW 2.0 Hdi 136 BlueHdi 136/180/150 3008/Blue 2.0 Hdi 150 5008/Blue 2.0 Hdi 150	18-7592970 STD 18-7592974 0.60	A = 46,600 B = 72,000 C = 12,710 CD= 51,300 Segman Taşıyıcı (Ring Carrier) Yag Galerisi (Oil Gallery)	RE47770000 -STD RE47770060 -0.60 2,000 () 2,000 () P 2,000 ()	ø30,0 x 68,0			
 							
ø85,00 4 Cyl. Diesel 2298 cc 74/107 KW (101/146 Ps) M9T EURO 4/5 ÇİFT TURBOLU ARAÇLAR M9T 710/702/700 2010 -	18-8092890 STD 18-8092890-20 STD (-0.20 mm) 18-8092893 0.50 18-8092893-20 0.50 (-0.20 mm)	A = 47,833 B = 74,000 C = 16,200 CD= 50,000 Segman Taşıyıcı (Ring Carrier) Yag Galerisi (Oil Gallery)	RE49540000 -STD RE49540050 -0.50 2,000 (503) CK 1,750 (501) IFU CR 2,000 (604) NIT	ø32,0 x 67,5			
 							



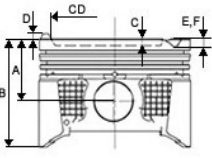



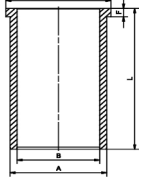
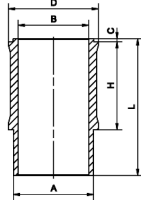

							
Motor /Engine	Ref. No. Kit 1	Ölçüler /Dimensions	Segman /Rings	Pim	Gömlek /Liner	Kit 2	Info
<p>ø86,00</p> <p>4 Cyl. Benzin, 1998 cm³ 85 115 kW X20SE 20SE 20SEH 20SER 20XE 20XEJ <u>1986-2000</u></p> <p>Astra Kadett Omega</p>	<p>18-3010620 STD 18-3010623 0.50</p>	<p>A = 30,400 B = 55,400 C = 5,000 CD= 45,000</p>	<p>RE43190000 -STD RE43190050 -0.50 RE43190100 -1.00</p> <p>1,500 (500) CrB S 1,500 (501) P 3,000 (700) Cr P S</p>	<p>ø21,0 x 61,5</p>			
<p>ø86,00</p> <p>4 Cyl. Benzin, 1998 cm³ 85 95 kW 20NE C20NE <u>1986-1998</u></p> <p>Omega Kadett Ascona Vectra Le Mans 2,0 Espero 2,0 Frontera</p>	<p>18-3010630 STD 18-3010633 0.50 18-3010638 1.00</p>	<p>A = 30,400 B = 55,400 C = 5,000 CD= 57,000</p> <p>Sac Plaka (Steel Support)</p>	<p>RE43190000 -STD RE43190050 -0.50 RE43190100 -1.00</p> <p>1,500 (500) CrB S 1,500 (501) P 3,000 (700) Cr P S</p>	<p>ø21,0 x 61,5</p>	<p>G89001350K_1</p> <p>A= 89,000 B= 85,300 D= 90,000 F= 5,000 H= 0,000 L= 135,000</p> 		



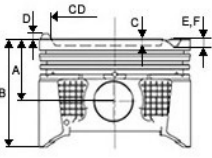





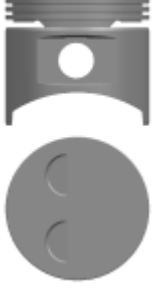
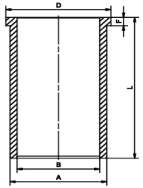
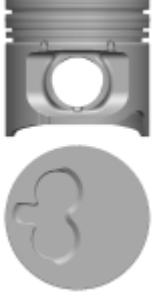

							
Motor /Engine	Ref. No. Kit 1	Ölçüler /Dimensions	Segman /Rings	Pim	Gömlek /Liner	Kit 2	Info
<p>ø86,00</p> <p>2.2 i 16v Z22SE <u>2000-2005</u></p> <p><i>Omega Kadett Ascona Vectra Zafira Astra</i></p>	<p>18-3010710 STD 18-3010713 0.50 18-3010718 1.00</p>	<p>A = 26,750 B = 48,900 C = 0,610 CD= 70,000</p> <p>Sert Anotlama (Hard Anodising)</p>	<p>RE43430000 -STD RE43430050 -0.50 RE43430100 -1.00</p> <p>1,200 (500) NitB S 1,500 (508) P 2,500 (700) Cr P S</p>	<p>ø20,0 x 62,8</p>	<p>G89001350K_1</p> <p>A= 89,000 B= 85,300 D= 90,000 F= 5,000 H= 0,000 L= 135,000</p> 		
<p>ø86,00</p> <p>V 6 Benzin, 2962 cm³ 155 kW (211 hp), 10 X30XE <u>1994-2001</u></p> <p><i>Omega B 24v Sintra Carlton</i></p>	<p>18-3010720 STD</p>	<p>A = 26,750 B = 48,900 C = 0,610 CD= 70,000</p>	<p>RE43190000 -STD RE43190050 -0.50 RE43190100 -1.00</p> <p>1,500 (500) CrB S 1,500 (501) P 3,000 (700) Cr P S</p>	<p>ø21,0 x 65,0</p>			

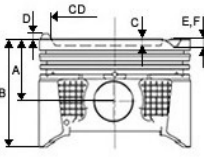



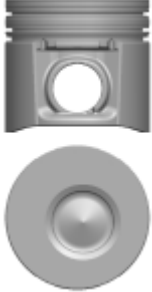

							
Motor /Engine	Ref. No. Kit 1	Ölçüler /Dimensions	Segman /Rings	Pim	Gömlek /Liner	Kit 2	Info
<p>ø86,00</p> <p>4 Cyl. Benzin, 1998/2198 cm³ 85/94/96/98 100/101/102 kW 116/128/131/133 136/137/139 PS C20 SEL X22 SE/XE/SEL</p> <p><u>1998-2000</u></p> <p>Omega Kadett Ascona Vectra Leganza Frontera</p>	<p>18-3010730 STD 18-3010733 0.50</p>	<p>A = 30,400 B = 55,400 C = 6,500 CD= 63,180</p>	<p>RE43190000 -STD RE43190050 -0.50 RE43190100 -1.00</p> <p>1,500 (500) CrB S 1,500 (501) P 3,000 (700) Cr P S</p>	<p>ø21,0 x 61,5</p>			
<p>ø86,00</p> <p>4 Cyl. Benzin, 1998 cm³ 110/115 kW (150/156 PS) C20XE 20XE</p> <p><u>1991-1998</u></p> <p>Omega Kadett Ascona Vectra Leganza Ventile Calibra Cavalier III</p>	<p>18-3010740 STD 18-3010743 0.50</p>	<p>A = 30,430 B = 55,430 C = 0,850 E = -1,930 CD= 70,000</p> <p>Sac Plaka (Steel Support)</p>	<p>RE43190000 -STD RE43190050 -0.50 RE43190100 -1.00</p> <p>1,500 (500) CrB S 1,500 (501) P 3,000 (700) Cr P S</p>	<p>ø21,0 x 61,5</p>	<p>G89001350K_1</p> <p>A= 89,000 B= 85,300 D= 90,000 F= 5,000 H= 0,000 L= 135,000</p> 		





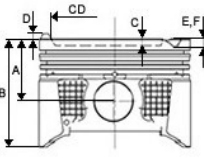
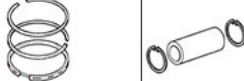

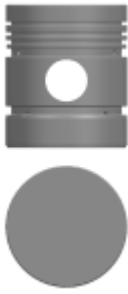

Motor /Engine	Ref. No. Kit 1	Ölçüler /Dimensions	Segman /Rings	Pim	Gömlek /Liner	Kit 2	Info
							
ø89,00 4 Cyl. Diesel 2463 cc 84 Kw (115 Ps) 17.75:1 Common Rail G9U Euro 3 720/724/730/750/754 <u>2001-2006</u> Master II 2,5 Dci OPEL/Movano Box Movano Platform Vivaro Box Vivaro Platform	18-3050290 STD 18-3050290-20 STD (-0.20 mm) 18-3050290-40 STD (-0.40 mm) 18-3050293 0.50 18-3050293-20 0.50 (-0.20 mm) 18-3050293-40 0.50 (-0.40 mm)	A = 53,030 B = 83,090 C = 17,850 E = -1,600 F = -2,000 CD= 43,200 Segman Taşıyıcı (Ring Carrier) Yag Püskürt. Oyugu (Oil Cut-Out)	RE49450000 -STD RE49450050 -0.50 2,500 (500) Cr P IF 1,750 (501) P IFU 2,500 (604) Cr P	ø31,0 x 65,0	G92001680K_1 A= 92,000 B= 88,300 D= 93,500 F= 5,000 H= 0,000 L= 168,000 		+0,35 +0,60
ø89,00 4 Cyl. Diesel 2463 cc 84 Kw (115 Ps) 17.75 G9U Euro 4 632/650 <u>2001-2006</u> Master II 2,5 Dci OPEL/Movano Box Movano Platform Vivaro Box Vivaro Platform	18-3050300 STD 18-3050303 0.50	A = 53,075 B = 83,090 C = 16,130 E = -1,600 F = -2,000 CD= 48,000 Segman Taşıyıcı (Ring Carrier)	RE49490000 -STD RE49490050 -0.50 3,000 (503) Cr P 1,750 (508) P 2,500 (604) Nit S	ø31,0 x 65,0	G92001680K_1 A= 92,000 B= 88,300 D= 93,500 F= 5,000 H= 0,000 L= 168,000 		

Motor /Engine	Ref. No. Kit 1	Ölçüler /Dimensions	Segman /Rings	Pim	Gömlek /Liner	Kit 2	Info
							
ø89,00 4 Diesel, 2464 cm ³ 74/107 kW (101/146 PS) 18:1 18,1:1,16 Ventile G9U 630 G9U 632 G9U 650 <u>10/2003</u> INTERSTAR DCI 100/120/150 PRIMASTAR DCI 150 MOVANO-A 2.5 CDTI VIVARO 2.5 CDTI/DTI TRAFIC II 2.5 DCI MASTER II 2.5 DCI	18-3092350 STD 18-3092353 0.50	A = 53,075 B = 83,090 C = 16,300 E = -2,000 F = -1,700 CD= 48,000 Segman Taşıyıcı (Ring Carrier) Yag Galerisi (Oil Gallery) Yag Püskürt. Oyugu (Oil Cut-Out)	RE49490000 -STD RE49490050 -0.50 3,000 (503) Cr P 1,750 (508) P 2,500 (604) Nit S	ø31,0 x 68,0	G92001680K_1 A= 92,000 B= 88,300 D= 93,500 F= 5,000 H= 0,000 L= 168,000 		
ø90,00 4 Cyl. Diesel 2112 cc 46/43/48/55/78 Kw (59/63/56/75/95/106 Ps) XD4.90 XDP4.90 XDP6.90WTA <u>1969....</u> J 72.1 D 504 2.1 D J 9 2.1 D J 7 2.1 D Granada 2.1 D Blitz 2.1 D	18-7550940 STD Gömleklı Kodu 19-7550940 STD 18-7550943 0.50 Gömleklı Kodu 19-7550943 0.50 18-7550948 1.00 Gömleklı Kodu 19-7550948 1.00	A = 57,200 B = 96,350 C = 2,000	RE47170000 -STD RE47170050 -STD RE47170100 -STD 2,000 (500) Cr 2,000 (501) P 2,000 (508) P 4,500 (604) P	ø28,0 x 77,0	G96001733S_1 A= 96,000 B= 90,000 D= 106,300 F= 0,000 H= 129,050 L= 173,350 		

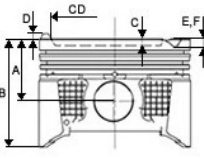





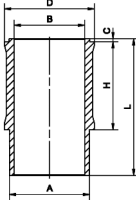

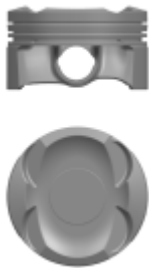
Motor /Engine	Ref. No. Kit 1	Ölçüler /Dimensions	Segman /Rings	Pim	Gömlek /Liner	Kit 2	Info
							
ø93,00 4 Cyl. Benzin 1897 cc 65/66/78KW (88/90/107 PS) 8,8:1 19E 19S 19SH 1965 - 1981 1.9 ASCONA A/B GT KADETT B/C MANTA A/B OLYMPIA REKORD S/SPRINT/1900 CAVALIER I S	18-3010520 STD 18-3010522 0.20 18-3010523 0.50 18-3010528 1.00 18-301052X 0.30 18-301052Z 0.20	A = 45,000 B = 87,000 E = -3,500	RE43280000 -STD RE43280020 -0.20 RE43280030 -0.30 RE43280040 -0.40 RE43280050 -0.50 RE43280100 -1.00 2,000 (500) Cr P IF 2,000 (506) P 5,000 (700) Cr P S	ø23,0 x 70,0			
	ø93,00 4 Cyl. Diesel 2499 cc 62 Kw (85 Ps) Atmospheric Göz Arası Konik SOFIM 2/5 Düz 2001 -.... Ducato 2.5 D Movano 2.5 D Master 2.5 D	18-3051880 STD 18-3051880-20 STD (-0.20 mm) 18-3051882 0.40 18-3051882-20 0.40 (-0.20 mm)	A = 54,000 B = 89,000 C = 2,200 Segman Taşıyıcı (Ring Carrier) Sert Anotlama (Hard Anodising) Yag Püskürt. Oyugu (Oil Cut-Out)	RE22340000 -STD RE22340040 -0.40 RE22340060 -0.60 3,000 (504) Cr P 2,000 (501) P 3,000 (604) Cr P	ø32,0 x 68,0	G96001670K_1 A= 96,000 B= 93,000 D= 98,900 F= 5,000 H= 0,000 L= 167,300 	+0,40 +0,50 1.20 mm Conta +0,51 +0,60 1.30 mm Conta +0,61 +0,70 1.40 mm Conta
							



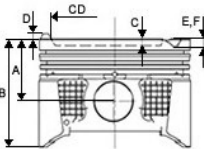



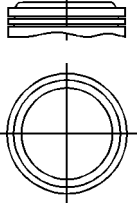
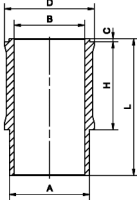
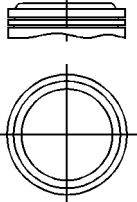
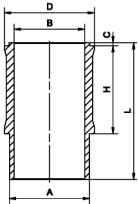

							
Motor /Engine	Ref. No. Kit 1	Ölçüler /Dimensions	Segman /Rings	Pim	Gömlek /Liner	Kit 2	Info
<p>ø94,40</p> <p>4 Cyl. Diesel 2798 cc 76 Kw (103 Ps) 18,5:1 Sofim Turbo,Intercooler Euro 2 SOFIM TurboS9W700 702</p> <p><u>1996 -....</u></p> <p>Movano 2.8 TD Ducato 2.8 TD 49.10 49.12 M14 Minibüs Turbo Daily35.12 Motor No: 2572280 --> Boxer 2.8 TD Master 2.8 TDI Jumper 2.8 TD</p>	<p>18-3051670 STD 18-3051670-20 STD (-0.20 mm)</p> <p>18-3051672 0.40 18-3051672-20 0.40 (-0.20 mm)</p> <p>18-3051674 0.60 18-3051674-20 0.60 (-0.20 mm)</p> 	<p>A = 58,750 B = 87,600 C = 19,400 CD= 39,500</p> <p>Segman Taşıyıcı (Ring Carrier)</p> <p>Yag Galerisi (Oil Gallery)</p> <p>Yag Püskürt. Oyugu (Oil Cut-Out)</p>	<p>RE22780000 -STD RE22780040 -0.40 RE22780060 -0.60</p> <p>2,500 (504) Cr P 2,000 (501) P 2,500 (604) Cr P</p>	<p>ø32,0 x 72,0</p>			<p>1,20 mm conta +0,40 +0,50</p> <p>1,30 mm conta +0,51 +0,60</p> <p>1,40 mm conta + 0,61 +0,70</p>
<p>ø95,00</p> <p>4/6 Cyl. Benzin 1979/2969 cc 74/130/135 kw (100/177 PS) 9,4:1 8/12 Ventile 20E 20S 30E 30NE</p> <p><u>1975 - 1990</u></p> <p>(2.0) ASCONA A/B GT KADETT C MANTA BE/BS OLYMPIA REKORD 2.0/E/S (3.0) MONZA-A OMEGA-A SENATOR I/II-A/B CARLTON I/III 1.9/2.0 I/3.0 CAVAILIER I/II 2.0/SROYALE 2.9/3.0</p>	<p>18-3010530 STD 18-3010533 0.50 18-3010538 1.00</p> 	<p>A = 45,000 B = 87,000 E = -3,500</p> <p>Sac Plaka (Steel Support)</p>	<p>RE43310000 -STD RE43310050 -0.50 RE43310100 -1.00</p> <p>2,000 (500) CrB S 2,000 (508) P 4,000 (700) P</p>	<p>ø23,0 x 76,0</p>			



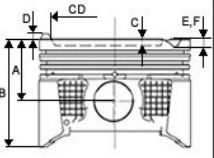



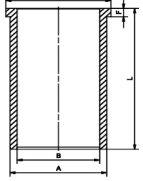
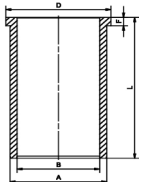

							
Motor /Engine	Ref. No. Kit 1	Ölçüler /Dimensions	Segman /Rings	Pim	Gömlek /Liner	Kit 2	Info
<p>ø91,48</p> <p>6 Cyl. Diesel PERKINS 71 3601 00 91,48 mm</p> <p>Perkins</p>	<p>18-6650110 STD</p>	<p>A = 61,730 B = 109,750 C = 18,400 CD= 55,900</p>	<p>RE45140000 -STD</p> <p>2,385 (500) Cr 2,385 (501) P 3,160 (508) 6,335 () 6,335 ()</p>	<p>ø31,8 x 75,3</p>			
<p>ø91,48</p> <p>6/4 Cyl. Benzin 5000/3335cc 52/73 KW 64/71/100PS 17,4:1 6.305 4.203</p> <p>Perkins-Jeep Viasa</p>	<p>17-6650120 STD</p>	<p>A = 57,200 B = 107,900</p>	<p>RE45140000 -STD</p> <p>2,385 (500) Cr 2,385 (501) P 3,160 (508) 6,335 () 6,335 ()</p>	<p>ø31,8 x 75,3</p>			



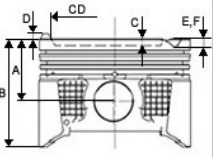



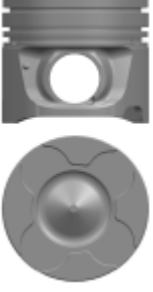
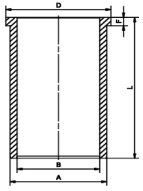
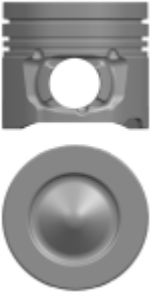

							
Motor /Engine	Ref. No. Kit 1	Ölçüler /Dimensions	Segman /Rings	Pim	Gömlek /Liner	Kit 2	Info
<p>ø70,00</p> <p>4 Cyl. Benzin 954 cc 31/33/37 42/45/50 ps TU9M/Z <u>1992 -</u> 205 1.0i 106 1.0i</p>	<p>18-7510510 STD Gömlikli Kodu 19-7510510 STD</p>	<p>A = 33,900 B = 58,000 D = 0,800</p>	<p>RE47360000 -STD RE47360050 -0.50</p> <p>1,500 (500) CrBSIF 1,500 (501) P 3,000 (700) CrPS</p>	<p>ø18,0 x 53,0</p>	<p>G79501220S_1</p> <p>A= 79,500 B= 70,000 D= 89,300 F= 0,000 H= 85,000 L= 122,000</p> 		
<p>ø71,00</p> <p>3 Cyl. Benzin 999 cc 50 kW 68 PS ZMZ (EBO EBOF) <u>2012 - 2019</u> ZMZ (EBO-EBOF)</p>	<p>17-7510080 STD 17-7510083 0.50</p>	<p>A = 28,650 B = 42,150 C = 4,400 E = -5,100 F = -6,100</p> <p>Sert Anotlama (Hard Anodising)</p>	<p>RE47680000 -STD RE47680050 -0.50</p> <p>1,000 () 1,000 () 2,000 ()</p>	<p>ø17,0 x 45,0</p>			



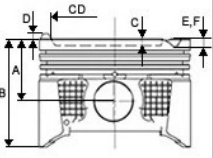



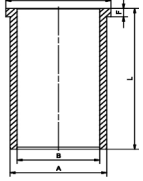
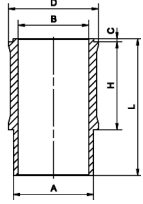

							
Motor /Engine	Ref. No. Kit 1	Ölçüler /Dimensions	Segman /Rings	Pim	Gömlek /Liner	Kit 2	Info
<p>ø72,00</p> <p>4 Cyl. Benzin, 1124 cm³ 37 kW (50 hp), 9,7:1 XW7 <u>1981 - 1986</u></p> <p>104 205</p>	<p>18-7510070 STD Gömleklili Kodu 19-7510070 STD</p> 	<p>A = 40,050 B = 73,700 D = 4,200</p>	<p>RE18020000 -STD</p> <p>1,500 (500) Cr S 2,000 (501) P 4,000 (700) Cr P S</p>	<p>ø19,5 x 62,0</p>	<p>G79501220S_2</p> <p>A= 79,500 B= 72,000 D= 89,300 F= 0,000 H= 85,000 L= 122,500</p> 		
<p>ø72,00</p> <p>4 Cyl. Benzin, 1124 cm³ 40 kW (54 hp) TU1 E1 A TU1K TU 1M XW3 XW3S XW7/A <u>1988-1992</u></p> <p>106 205 306 309 Partner</p>	<p>18-7510130 STD Gömleklili Kodu 19-7510130 STD</p> 	<p>A = 40,000 B = 67,000 D = 3,000</p>	<p>RE18020000 -STD</p> <p>1,500 (500) Cr S 2,000 (501) P 4,000 (700) Cr P S</p>	<p>ø19,5 x 62,0</p>	<p>G79501220S_2</p> <p>A= 79,500 B= 72,000 D= 89,300 F= 0,000 H= 85,000 L= 122,500</p> 		



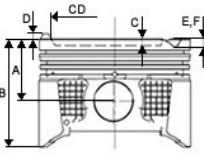
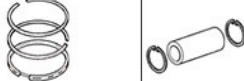



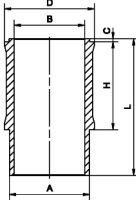

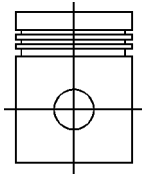

Motor /Engine	Ref. No. Kit 1	Ölçüler /Dimensions	Segman /Rings	Pim	Gömlek /Liner	Kit 2	Info
							
ø73,70 4 Cyl. Diesel 1399 cc 50 Kw (68 Ps) DV4TD DV4 TED DV4C TED F6JA F6JB 8HX 8HR 8HZ 8HS 2002 -.... Fiesta V 1.4 TDCI Fusion 1.4 TDCI Mazda 2 1,4D C2 1.4 HDI C3 I 1.4 HDI XSARA 1.4 HDI NEMO 1.4 HDI 1007 1.4 HDI 107 1.4 HDI 206 1.4 HDI 207 1.4 HDI 307 1.4 HDI BIPPER 1.4 HDI	18-2550150 STD 18-2550150-20 STD (-0.20 mm) 18-2550150-40 STD (-0.40 mm) 18-2550153 0.50 18-2550153-20 0.50 (-0.20 mm) 18-2550153-40 0.50 (-0.40 mm)	A = 42,940 B = 65,440 C = 14,700 E = -1,550 CD= 37,600 Segman Taşıyıcı (Ring Carrier) Yag Püskürt. Oyugu (Oil Cut-Out)	RK25273700010 -STD RK25273700013 -0.50 2,500 (505) Cr B P 1,950 (508) P IFU 2,500 (604) Cr P	ø25,0 x 60,0	G76701360K_1 A= 76,700 B= 73,000 D= 78,200 F= 5,000 H= 0,000 L= 136,000 	1 çentik 1,351mm conta +0,776 +0,825 2 çentik 1,252mm conta +0,618 +0,725 3 çentik 1,303mm conta +0,726 +0,775 4 çentik 1,400mm conta +0,83 +0,88 5 çentik 1,450mm conta +0,88 0,98	
ø73,70 4 Cyl. Diesel 1398cc 68 HP 50 KW DV4C Euro 5 2010 -.... Fiesta V 1.4 TDCI	18-2550160 STD 18-2550163 0.50	A = 42,900 B = 65,400 C = 12,500 CD= 45,100 Segman Taşıyıcı (Ring Carrier) Yag Püskürt. Oyugu (Oil Cut-Out)	RE23580000 -STD RE23580050 -0.50 2,500 (514) Cr P 1,950 (508) P IFU 2,000 (604) Nit S	ø25,0 x 60,0	G73701360K_1 A= 76,700 B= 68,900 D= 78,200 F= 5,000 H= 0,000 L= 142,000 		

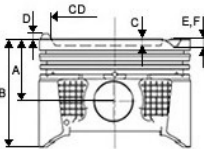





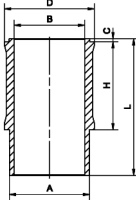

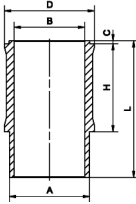
Motor /Engine	Ref. No. Kit 1	Ölçüler /Dimensions	Segman /Rings	Pim	Gömlek /Liner	Kit 2	Info
							
ø73,70 4 Cyl. Diesel, 1398 cm ³ 50/66kW (68PS/90PS) 17,5:1,16 Ventile,T 8HY (DV4TED4) 8HS (DV4TED), Euro 4 <u>02/2002...04/2005</u> C3 I 1.4 HDI Peugeot Turbo	18-7592160 STD 18-7592161 0.25 18-7592163 0.50	A = 42,940 B = 65,440 C = 14,390 E = -1,180 CD= 37,160 Segman Taşıyıcı (Ring Carrier) Yag Galerisi (Oil Gallery) Yag Püskürt. Oyugu (Oil Cut-Out)	RE23050000 -STD RE23050050 -0.50 2,500 (505) CrB P 1,950 (508) P IFU 2,500 (604) Cr P	ø24,9 x 60,0			
							
ø75,00 4 Cyl. Diesel 1560cc 70 Kw (95 Ps) 1.6 HDİ (DV6C) EUR5 1.6 HDİ (DV6D) Euro 4 <u>2011 -</u> FOCUS BERLINGO 1.6 8V C4 (B7) DS4 (9HR-9HL) DS5 Grand Picasso II C4 DS4 DS3 C3 C3 II 3008 308 5008 508 Partner Tepee 2008 308 SW 207 SW 208 207	18-2581660 STD 18-2581660-20 STD (-0.20 mm) 18-2581660-40 STD (-0.40 mm) 18-2581663 0.50 18-2581663-20 0.50 (-0.20 mm) 18-2581663-40 0.50 (-0.40 mm)	A = 41,750 B = 65,200 C = 13,850 CD= 45,000 Segman Taşıyıcı (Ring Carrier) Yag Galerisi (Oil Gallery) Yag Püskürt. Oyugu (Oil Cut-Out)	RE23550000 -STD RE23550050 -0.50 2,500 (514) Cr P 1,950 (508) P 2,000 (604) Nit S	ø26,0 x 61,0	G78001420K_1 A= 78,000 B= 74,300 D= 79,500 F= 5,000 H= 0,000 L= 142,000		1 Kertik 0,5 mm 0,63 mm 2 Kertik 0,63 mm 0,68 mm 3 Kertik 0,68 mm 0,73 mm 4 Kertik 0,73 mm 0,78 mm 5 Kertik 0,78 mm 0,88 mm
							

Motor /Engine	Ref. No. Kit 1	Ölçüler /Dimensions	Segman /Rings	Pim	Gömlek /Liner	Kit 2	Info
       							
ø75,00 4 Cyl. Diesel 1560 cc 80 Kw (109 Ps) DV6TD/TED 2004 -.... Expert 1,6 HDI 307 1,6 HDI 206 1,6 HDI C4 1,6 HDI Jumpy 1,6 HDI C-Max 1,6 HDI Focus 1,6 HDI	18-2591770 STD 18-2591770-20 STD (-0.20 mm) 18-2591770-40 STD (-0.40 mm) 18-2591773 0.50 18-2591773-20 0.50 (-0.20 mm) 18-2591773-40 0.50 (-0.40 mm) 18-2591774 0.60 18-2591774-20 0.60 (-0.20 mm) 18-2591774-40 0.60 (-0.40 mm)	A = 41,700 B = 65,300 C = 13,250 E = -1,200 CD= 41,800 Segman Taşıyıcı (Ring Carrier) Yag Galerisi (Oil Gallery) Yag Püskürt. Oyugu (Oil Cut-Out)	RE47460000 -STD RE47460040 -0.40 RE47460050 -0.50 RE47460060 -0.60 3,000 (505) CKP 1,950 (508) P 2,500 (604) CrP	ø26,0 x 61,0	G78001420K_1 A= 78,000 B= 74,300 D= 79,500 F= 5,000 H= 0,000 L= 142,000		1.35 mm conta +0,68 +0,73 1.25 mm conta +0,53 +0,63 1.30 mm conta +0,63 +0,68 1.40 mm conta +0,73 +0,78 1.45 mm conta +0,78 +0,88
ø75,00 4 Cyl. Benzin, 1361 cm ³ 55 kW (75 hp), 10,5:1 Düz Tepe TU3JPL4 KFW(TU3JP) KFX(TU3JP) 2004 -.... Berlingo 1.4 I Saxo 1.4 I Xsara 1.4 I 106 II 1.4 I 205 II 1.4 I 206 1.4 I 306 1.4 I 307 1.4 I Partner 1.4 I	18-7510060 STD Gömleklili Kodu 19-7510060 STD 18-7510063 0.50 Gömleklili Kodu 19-7510063 0.50	A = 27,750 B = 49,930	RE47580000 -STD RE47580050 -0.50 1,500 (500) CrB Fe S IF 1,500 (501) P 2,500 (700) Cr P S	ø18,0 x 55,0	G79501350S_1 A= 79,500 B= 75,000 D= 89,300 F= 0,000 H= 90,000 L= 135,000		

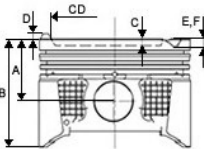





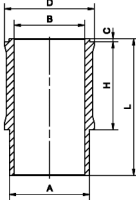

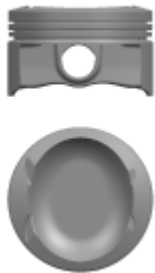
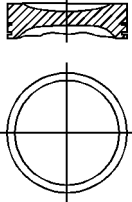

							
Motor /Engine	Ref. No. Kit 1	Ölçüler /Dimensions	Segman /Rings	Pim	Gömlek /Liner	Kit 2	Info
<p>ø75,00</p> <p>4. Cyl. Benzin 1361cc 54/55 kW 73/75 PS TU3JP <u>2005 -</u></p> <p><i>PARTNER 1.4i</i> <i>1007 1.4i</i> <i>307 1.4i</i> <i>306 1.4i</i> <i>206 1.4i</i> <i>RANCH 1.4i</i> <i>106 1.4i</i></p>	<p>18-7510090 STD Gömlikli Kodu 19-7510090 STD</p>	<p>A = 27,850 B = 49,700 C = 1,250 CD= 65,000</p>	<p>RE47580000 -STD RE47580050 -0.50</p> <p>1,500 (500) CrB Fe S IF 1,500 (501) P 2,500 (700) Cr P S</p>	<p>ø18,0 x 55,0</p>	<p>G79501350S_1</p> <p>A= 79,500 B= 75,000 D= 89,300 F= 0,000 H= 90,000 L= 135,000</p> 		
<p>ø75,00</p> <p>4 Cyl. Benzin, 1218 cm³ 42 kW (57 hp) XZ5 XY6B XY7 XYB XYR <u>1978 - 1984</u></p>	<p>18-7510100 STD</p>	<p>A = 28,250 B = 52,330 D = 1,300 E = -3,100</p>	<p>RE47000000 -STD RE47000050 -0.50</p> <p>1,750 (500) CrBSIF 2,000 (508) P 3,000 (700) CrPS</p>	<p>ø19,5 x 62,0</p>			

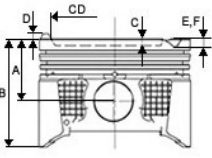





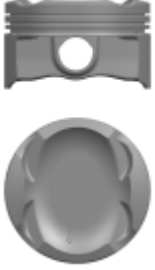





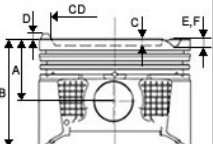





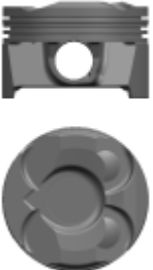

							
Motor /Engine	Ref. No. Kit 1	Ölçüler /Dimensions	Segman /Rings	Pim	Gömlek /Liner	Kit 2	Info
<p>ø75,00</p> <p>4 Cyl. Benzin, 1361 cm³ 65 kW (88 hp) KFU(ET 3 J4) <u>2003 -....</u></p> <p>C 2 1.4 I C 3 1.4 I C 4 1.4 1007 1.4 I 206 1.4 207 1.4 307 1.4</p> 	<p>18-7510110 STD Gömleklili Kodu 19-7510110 STD 18-7510113 0.50 Gömleklili Kodu 19-7510113 0.50</p>	<p>A = 28,250 B = 52,330 D = 1,300 E = -3,100</p>	<p>RE47590000 -STD RE47590050 -0.50</p> <p>1,200 (500) Cr P 1,500 (508) P 2,500 (604) P</p>	<p>ø18,0 x 44,5</p>	<p>G79501350S_1</p> <p>A= 79,500 B= 75,000 D= 89,300 F= 0,000 H= 90,000 L= 135,000</p> 		
<p>ø75,00</p> <p>4 Cyl. Benzin, 1361 cm³ 55 kW (75 hp), 10,5:1 TU3JPL4 KFW(TU3JP) KFX(TU3JP) <u>2004 -....</u></p> <p>Berlingo 1.4 I Saxo 1.4 I Xsara 1.4 I 106 II 1.4 I 205 II 1.4 I 206 1.4 I 306 1.4 I 307 1.4 I Partner 1.4 I</p> 	<p>18-7510120 STD Gömleklili Kodu 19-7510120 STD 18-7510123 0.50 Gömleklili Kodu 19-7510123 0.50</p>	<p>A = 27,750 B = 49,930 D = 0,180</p>	<p>RE47580000 -STD RE47580050 -0.50</p> <p>1,500 (500) CrB Fe S IF 1,500 (501) P 2,500 (700) Cr P S</p>	<p>ø18,0 x 55,0</p>	<p>G79501350S_1</p> <p>A= 79,500 B= 75,000 D= 89,300 F= 0,000 H= 90,000 L= 135,000</p> 		



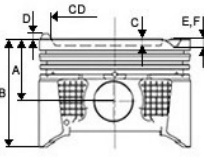







							
Motor /Engine	Ref. No. Kit 1	Ölçüler /Dimensions	Segman /Rings	Pim	Gömlek /Liner	Kit 2	Info
<p>ø75,00</p> <p>4 Cyl. Benzin, 1361 cm³ 44 55 kW (60 75 hp) 9,3:1 TU3A <u>1987-1992</u></p> <p>106 205 206 306 309 Partner</p>	<p>18-7510270 STD Gömleklili Kodu 19-7510270 STD 18-7510273 0.50 Gömleklili Kodu 19-7510273 0.50</p>	<p>A = 40,500 B = 64,500 C = 1,100 CD= 63,000</p>	<p>RE47000000 -STD RE47000050 -0.50</p> <p>1,750 (500) CrBSIF 2,000 (508) P 3,000 (700) CrPS</p>	<p>ø19,5 x 62,0</p>	<p>G79501350S_1</p> <p>A= 79,500 B= 75,000 D= 89,300 F= 0,000 H= 90,000 L= 135,000</p> 		
<p>ø75,00</p> <p>3 Cyl. Benzin. 1199cc 53kW (72ps) 1.2 VTi (72 Hp) Euro 5 EB2 M 301 1.2 16V <u>2012 -....</u></p> <p>C-Elysee 1.2 VTi 301 1.2 VTi</p>	<p>17-7511270 STD 17-7511273 0.50</p>	<p>A = 28,810 B = 46,820 C = 8,000 E = -1,200 CD= 64,500</p> <p>Sert Anotlama (Hard Anodising)</p>	<p>RE18520000 -STD RE18520050 -0.50</p> <p>1,000 (910) NIT SY 1,000 (931) FE S 2,000 (947) EX NIT S</p>	<p>ø17,0 x 51,0</p>			

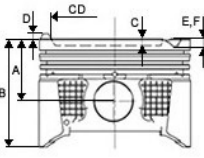





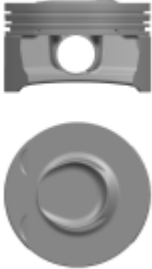





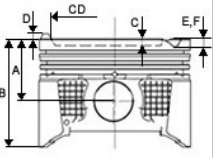



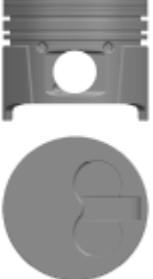
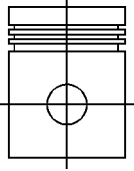
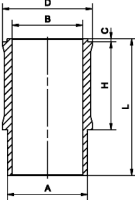

Motor /Engine	Ref. No. Kit 1	Ölçüler /Dimensions	Segman /Rings	Pim	Gömlek /Liner	Kit 2	Info
       							
ø75,00 3 Cyl.Benzin.1199cc 50/55/60/61kW 68/75/82/83 PS 1.2 l HMM EB2FAD HMP EB2FB HMX EB2 MHZEB2 D/F 12 XE EB2FA <u>2012 -....</u> 1,2 VTi (82 Hp) Euro 5-EB2 108 2008 208 308II-D 12 XE F 12 XE	17-7511280 STD 17-7511283 0.50	A = 26,500 B = 45,000 C = 5,300 Sert Anotlama (Hard Anodising)	RE18520000 -STD RE18520050 -0.50 1,000 (910) NIT SY 1,000 (931) FE S 2,000 (947) EX NIT S	ø17,0 x 51,0			
							
ø75,00 3 Cyl.Benzin.1199 cc 81/96kW 110/130/131 EB2DTS EB2DT 1.2 12V e THP 110/130 <u>2013/01 -....</u> 208 I (CA, CC) 308 II/SW II 2008 (CU) 3008 MPV (OU,)/SUV (M,) 5008 (OU, OE,)/II PARTNER Tepee	17-7511290 STD 17-7511293 0.50	A = 28,450 B = 50,000 D = 4,700 E = -4,200 F = -3,300 Sert Anotlama (Hard Anodising)	RE47660000 -STD RE47660050 -0.50 1,200 () 1,000 () 2,000 ()	ø19,5 x 45,0			
							

Motor /Engine	Ref. No. Kit 1	Ölçüler /Dimensions	Segman /Rings	Pim	Gömlek /Liner	Kit 2	Info
       							
ø77,00 4 Cyl.Benzin 1598 cc 75/88/90/147 102/120/122/200 PS BMW N 13 B16A MINI N18 B 16A 5FU(EP6CDTX/EP6DTX) 5FW(EP6) 2010 -.... BMW 116i MINI COOPER S 1.6i 16V PEUGEOT 77 MM	18-5510310 STD 18-5510310-30 STD 18-5510313 0.50 18-5510313-30 0.50	A = 28,500 B = 51,200 C = 3,500 D = 2,700 E = -3,300 F = -3,400 CD= 34,700 Sert Anotlama (Hard Anodising)	RE15260000 -STD RE15260000_NPR -STD x 48,0 RE15260050 -0.50 RE15260050_NPR -0.50 1,200 (500) Cr S IF 1,500 (508) P 2,000 (700) Cr P S	ø20,0 x 48,0			
							
ø77,00 4 Cyl.Benzin 1598 cc EP6 EP6C 2010 -.... 3008 16i 16V 5008 1.6i 2 207 1.6 16V 308 1.6 16V	18-5510320 STD 18-5510323 0.50	A = 27,500 B = 47,500 C = 2,000 E = -5,700 F = -3,800 CD= 56,600	RE15260000 -STD RE15260000_NPR -STD x 43,0 RE15260050 -0.50 RE15260050_NPR -0.50 1,200 (500) Cr S IF 1,500 (508) P 2,000 (700) Cr P S	ø18,0 x 43,0			
							

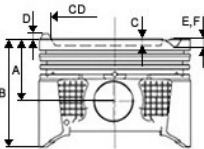





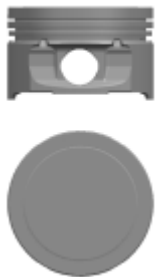
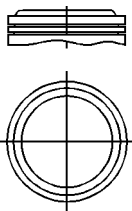

							
Motor /Engine	Ref. No. Kit 1	Ölçüler /Dimensions	Segman /Rings	Pim	Gömlek /Liner	Kit 2	Info
<p>ø77,00</p> <p>4 Cyl. Benzin 1598 cc (175PS) 115 156 PS 2010 ÖNCESİ EP6D1.6L R55 R56 R57 <u>2007-2010</u></p> <p>MINI COOPER 208 3008 308 508</p>	<p>18-5510330 STD 18-5510330-30 STD 18-5510333 0.50 18-5510333-30 0.50</p>	<p>A = 28,500 B = 51,200 C = 3,500 D = 2,700 E = -3,300 F = -3,400 CD= 34,700</p> <p>Sert Anotlama (Hard Anodising)</p>	<p>RE15260000 -STD RE15260000_NPR -STD x 48,0 RE15260050 -0.50 RE15260050_NPR -0.50</p> <p>1,200 (500) Cr S IF 1,500 (508) P 2,000 (700) Cr P S</p>	<p>ø20,0</p>			
<p>ø77,00</p> <p>4 Cyl. Benzin 1598 cc (175PS) EP6CDT 5FV 5FX 5FY EP6DT EP6DTS <u>2010 -</u></p> <p>207 3008 5008 508 RC23008 3008 I 3008 II 3008 SV</p>	<p>18-5510370 STD 18-5510373 0.50</p>	<p>A = 28,500 B = 51,200 C = 3,500 D = 2,700 E = -3,300 F = -3,400 CD= 34,700</p> <p>Sert Anotlama (Hard Anodising)</p>	<p>RE15260000 -STD RE15260000_NPR -STD x 48,0 RE15260050 -0.50 RE15260050_NPR -0.50</p> <p>1,200 (500) Cr S IF 1,500 (508) P 2,000 (700) Cr P S</p>	<p>ø20,0</p>			



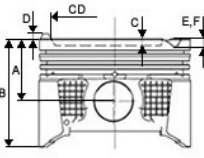





							
Motor /Engine	Ref. No. Kit 1	Ölçüler /Dimensions	Segman /Rings	Pim	Gömlek /Liner	Kit 2	Info
<p>ø77,00</p> <p>4Cyl. Benzin 1.6 BlueHDi 100 1.6 16V 1.6HDi 1.6 1.6 THP <u>2009 - 2016</u></p> <p><i>C4 Grand Picasso II 308 CC (4B_) RCZ 308 SW Peugeot 3008/308 SW RCZ Citroën C6 DS</i></p>	<p>18-7510160 STD 18-7510163 0.50</p> 	<p>A = 27,000 B = 47,000 C = 2,000 D = 3,500 CD= 34,800</p> <p>Sert Anotlama (Hard Anodising)</p>		<p>ø20,0 x 48,0</p>			
<p>ø77,00</p> <p>4 Cyl. Benzin 1397 cc 50/70 kW 75/95 PS EP3 N12B14A-.....</p> <p><i>207 WA/WC 1.4 16V 207 SW (WK) 1.4 16V 308 4A/4C 1.4 16V</i></p>	<p>18-7510280 STD 18-7510283 0.50</p> 	<p>A = 27,600 B = 47,500 D = 3,100</p>	<p>RE15260000 -STD RE15260000_NPR -STD RE15260050 -0.50 RE15260050_NPR -0.50</p> <p>1,200 (500) Cr S IF 1,500 (508) P 2,000 (700) Cr P S</p>	<p>ø18,0 x 43,0</p>			



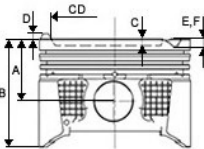





Motor /Engine	Ref. No. Kit 1	Ölçüler /Dimensions	Segman /Rings	Pim	Gömlek /Liner	Kit 2	Info
							
ø77,00 4 Cyl. Diesel 1527cc 37 42 Kw (50 57 Ps) VJX VJY VJZ (TUD5) TUD 5 1994 -.... 106 II Micro 1.5D Saxo 1.5D XSara 1.5D 106 1.5D 2 Serisi	18-7550420 STD 18-7550422 0.40	A = 40,400 B = 66,300 C = 1,580 E = -2,040 Yag Püskürt. Oyugu (Oil Cut-Out)	RE47270000 -STD RE47270040 -0.40 2,000 (500) Cr P 1,750 (501) P 3,000 (604) Cr P	ø23,0 x 60,0			+1,04 +1,14
							
ø78,00 4 Cyl. Benzin, 1290 cm ³ 44 48 kW (60 65 hp) XL5 1976-1988 305 SR	18-7510140 STD Gömleki Kodu 19-7510140 STD 18-7510143 0.50 Gömleki Kodu 19-7510143 0.50	A = 36,100 B = 72,300	RE47400000 -STD RE47400050 -0.50 1,750 (500) CrB S IF 2,000 (501) P 4,000 (604) P	ø20,5 x 68,0	G78451340S_1 A= 78,450 B= 73,000 D= 88,000 F= 0,000 H= 94,850 L= 134,000		
							



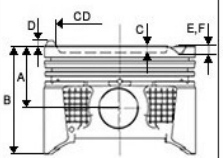





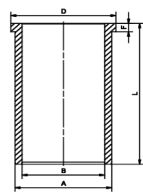
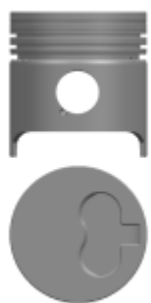

							
Motor /Engine	Ref. No. Kit 1	Ölçüler /Dimensions	Segman /Rings	Pim	Gömlek /Liner	Kit 2	Info
<p>ø78,00</p> <p>4 Cyl. Benzin, 1472 cm³ 49 58 kW (67 79 hp) XR5 <u>1977 -....</u> 305 SR</p>	<p>18-7510150 STD 18-7510153 0.50</p>	<p>A = 36,100 B = 73,100 D = 0,400</p>	<p>RE47400000 -STD RE47400050 -0.50</p> <p>1,750 (500) CrB S IF 2,000 (501) P 4,000 (604) P</p>	<p>ø20,5 x 68,0</p>			
<p>ø78,50</p> <p>4 Cyl. Benzin 1587 cc 80 Kw (109 Ps) TU5JP4 Euro3 <u>2000 -....</u> C3 1.6i 16V Berlingo 1.6i 16v 206 1.6i 16v 307 1.6i 16v Partner 1.6i 16v</p>	<p>18-7510700 STD 18-7510703 0.50</p>	<p>A = 32,350 B = 50,150 D = 0,150</p> <p>Yag Püskürt. Oyugu (Oil Cut-Out)</p>	<p>RE47380000 -STD RE47380025 -0.25 RE47380040 -0.40 RE47380050 -0.50 RE47380100 -1.00</p> <p>1,200 (500) MoB N S 1,500 (508) P 2,500 (604) P</p>	<p>ø19,6 x 57,0</p>			

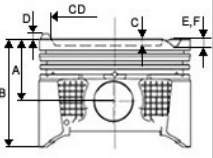





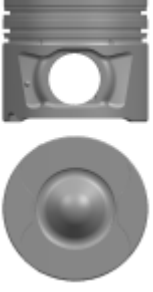
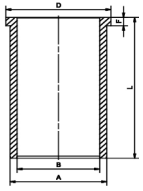





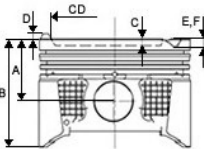



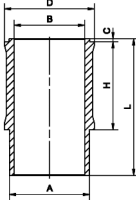
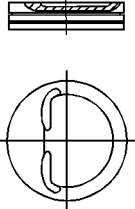
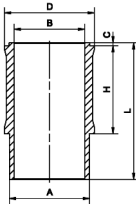

							
Motor /Engine	Ref. No. Kit 1	Ölçüler /Dimensions	Segman /Rings	Pim	Gömlek /Liner	Kit 2	Info
<p>ø78,50</p> <p>4 Cyl. Benzin 1587 cc 80 Kw (118 Ps) 10,8:1 16 Ventile NFX (TU5J4) <u>05/1996 -....</u></p> <p>106 GTI 106 II 1.6 206 306 307</p>	<p>18-7510710 STD 18-7510711 0.25 18-7510713 0.50</p>	<p>A = 32,500 B = 57,800 C = 1,200</p>	<p>RE47280000 -STD RE47280000_NPR -STD RE47280025 -0.25 RE47280050 -0.50</p> <p>1,500 (500) Cr P S IF 1,500 (508) P 3,000 (700) Cr P S</p>	<p>ø19,5 x 59,0</p>			
<p>ø78,50</p> <p>4 Cyl. Benzin 85 kw 115 HP EC5 1.6 VTI EURO 5 <u>2012 -</u></p> <p>301 C-ELYSEE</p>	<p>18-7510820 STD 18-7510823 0.50</p>	<p>A = 32,350 B = 53,750 D = 1,400 E = -2,450</p>	<p>RE47650000 -STD RE47650050 -0.50</p> <p>1,000 (500) Nit S IF 1,200 (508) P 2,000 (604) Nit S</p>	<p>ø19,6 x 57,0</p>			



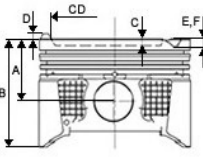



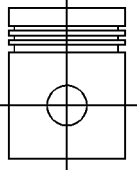
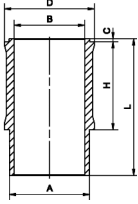
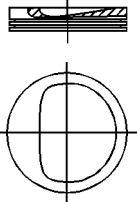
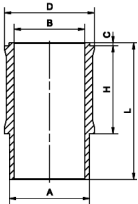

							
Motor /Engine	Ref. No. Kit 1	Ölçüler /Dimensions	Segman /Rings	Pim	Gömlek /Liner	Kit 2	Info
<p>ø78,50</p> <p>4 Cyl. Benzin, 1587 cm³ 65 kW (88 hp) TU5JP <u>1996 - 1998</u></p> <p>1,6i (8v/16v) C3 Berlingo 206 207 307 Partner</p>	<p>18-7510880 STD 18-7510882 0.40 18-7510883 0.50</p>	<p>A = 32,250 B = 57,500 C = 1,500 CD= 68,500</p>	<p>RE47280000 -STD RE47280000_NPR -STD RE47280025 -0.25 RE47280050 -0.50</p> <p>1,500 (500) Cr P S IF 1,500 (508) P 3,000 (700) Cr P S</p>	<p>ø19,5 x 61,9</p>			
<p>ø78,60</p> <p>4 Cyl. Benzin 87 kw 114 Ps EF7 <u>2008 -</u></p> <p>IKCO Dena SAMAND SOREN</p>	<p>18-7510810 STD 18-7510811 0.25 18-7510813 0.50</p>	<p>A = 29,700 B = 51,700 C = 3,550</p>	<p>RE47620000 -STD RE47620025 -0.25 RE47620050 -0.50</p> <p>1,200 (500) CrB Fe S 1,500 (508) P 2,500 (700) P S</p>	<p>ø21,0 x 58,0</p>			



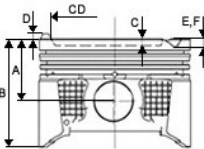



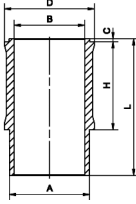
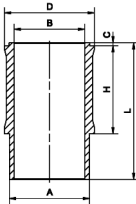
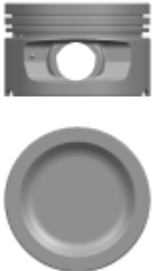

Motor /Engine	Ref. No. Kit 1	Ölçüler /Dimensions	Segman /Rings	Pim	Gömlek /Liner	Kit 2	Info
							
ø80,00 4 Cyl. Diesel 1768 cc 22:1 Turbo XUD7T TE TEY <u>1995 -....</u> 205 TD 309TD SRD GRD SXD XSD,405TD SRD GRD GTD	18-7550430 STD 18-7550433 0.50 18-7550437 0.80	A = 46,800 B = 84,500 C = 2,200 Segman Taşıyıcı (Ring Carrier) Sert Anotlama (Hard Anodising) Yag Püskürt. Oyugu (Oil Cut-Out)	RE47050000 -STD RE47050050 -0.50 RE47050080 -0.80 3,000 (504) Cr 2,000 (501) P 3,000 (604) Cr P	ø28,0 x 68,0			1. Tamir + 0,54 + 0,65 2. Tamir + 0,65 + 0,77 3. Tamir + 0,77 + 0,82
ø80,00 4 Cyl. Diesel, 1769 cm ³ 44 kW (60 PS) 23:1 8 Ventile XUD7 <u>1985 - 1993</u> 205 I 1.7 D 205 II 1.7 D 305 II 1.8 D 306 1.8 D BIPPER 1.8 D	18-7550440 STD 18-7550443 0.50 18-7550447 0.80	A = 46,800 B = 84,500 C = 2,000	RE47060000 -STD RE47060050 -0.50 RE47060080 -0.80 RE47060100 -1.00 2,000 (500) CrB S 2,000 (501) P 3,000 (604) Cr P	ø25,0 x 69,8	G83001540K_1 A= 83,000 B= 80,000 D= 86,000 F= 4,500 H= 0,000 L= 154,000 		



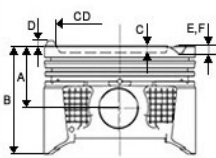



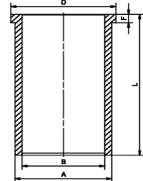

Motor /Engine	Ref. No. Kit 1	Ölçüler /Dimensions	Segman /Rings	Pim	Gömlek /Liner	Kit 2	Info
							
ø81,00 4/6/8 Cyl. Diesel 2720cc 150/200 KW(204/272 PS) 2.7 Lion TVM 276DT 368DT 2008 -..... DISCOVERY 2.7 TDI RANGE ROVER 2.7TDV6 (2008 -) RANGE ROVER SPORT (L320) 3.6 D 4x4 (04,2006 - 03,2013)	17-6592100 STD 17-6592103 0.50	A = 47,000 B = 71,000 C = 14,050 E = -0,500 CD= 44,000 Segman Taşıyıcı (Ring Carrier) Yag Galerisi (Oil Gallery)	RE47570000 -STD RE47570050 -0.50 2,000 (500) Cr PIF 2,000 (501) P IFU 2,000 (604) Nit S	ø29,0 x 62,0			
	ø82,20 4 Cyl. Diesel 1868 cc 51 Kw (71 Ps) 23:1 DW8 1998 -..... 206 1.9 D 306 1.9 D Expert 1.9 D Partner 1.9 D	18-7550460 STD 18-7550460-20 STD (-0.20 mm) 18-7550463 0.50 18-7550463-20 0.50 (-0.20 mm) 18-7550464 0.60 18-7550464-20 0.60 (-0.20 mm) 18-7550467 0.80 18-7550467-20 0.80 (-0.20 mm) 18-7550468 1.00 18-7550468-20 1.00 (-0.20 mm)	A = 46,730 B = 78,000 C = 1,300 Yag Püskürt. Oyugu (Oil Cut-Out)	RE47430000 -STD RE47430050 -0.50 RE47430060 -0.60 RE47430080 -0.80 RE47430100 -1.00 2,000 (500) CrBS 2,000 (508) P 3,000 (604) Cr	ø25,0 x 66,0	G82201540K_1 A= 85,050 B= 81,500 D= 86,950 F= 5,100 H= 0,000 L= 154,000 	1.26 mm conta + 0,51 + 0,55 1.30 mm conta + 0,55 + 0,59 1.34 mm conta + 0,59 + 0,63
							



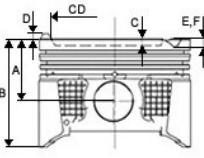



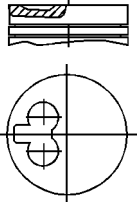

							
Motor /Engine	Ref. No. Kit 1	Ölçüler /Dimensions	Segman /Rings	Pim	Gömlek /Liner	Kit 2	Info
<p>ø83,00</p> <p>4 Cyl. Benzin 1580 cc 9,5:1 XU5 S 2C 1C CP</p> <p><u>1982 - 1990</u></p> <p>205 Automatic Open XR XS XT 305GL</p>	<p>18-7510180 STD Gömleklili Kodu 19-7510180 STD</p> <p>18-7510183 0.50 Gömleklili Kodu 19-7510183 0.50</p> 	<p>A = 37,500 B = 67,500 C = 2,100</p>	<p>RE47080000 -STD RE47080050 -0.50 RE47080080 -0.80</p> <p>1,750 (500) CrB S IF 1,750 (508) P 4,000 (700) Cr P S</p>	<p>ø22,0 x 66,0</p>	<p>G88601410S_1</p> <p>A= 88,540 B= 83,000 D= 97,000 F= 0,000 H= 95,140 L= 141,000</p> 		
<p>ø83,00</p> <p>4 Cyl. Benzin, 1580 cm³ 59 66 kW (80 90 hp) XU52C CR</p> <p><u>1982 - 1990</u></p> <p>309 405 1983></p>	<p>18-7510190 STD Gömleklili Kodu 19-7510190 STD</p> 	<p>A = 37,500 B = 67,500 C = 2,900</p>	<p>RE47080000 -STD RE47080050 -0.50 RE47080080 -0.80</p> <p>1,750 (500) CrB S IF 1,750 (508) P 4,000 (700) Cr P S</p>	<p>ø22,0 x 66,2</p>	<p>G88601410S_1</p> <p>A= 88,540 B= 83,000 D= 97,000 F= 0,000 H= 95,140 L= 141,000</p> 		



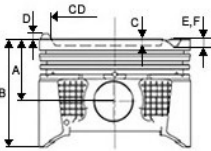



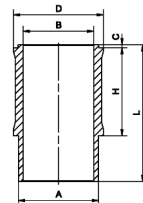

							
Motor /Engine	Ref. No. Kit 1	Ölçüler /Dimensions	Segman /Rings	Pim	Gömlek /Liner	Kit 2	Info
<p>ø83,00</p> <p>4 Cyl. Benzin, 1905 cm³ 88 90 kW (120 122 hp) 9,3:1 XU9J2 <u>1987 -....</u></p> <p>309 405</p>	<p>18-7510340 STD Gömleklili Kodu 19-7510340 STD</p> 	<p>A = 37,500 B = 67,500</p> <p>Sac Plaka (Steel Support)</p>	<p>RE47090000 -STD RE47090050 -0.50</p> <p>1,500 (500) CrB S IF 1,500 (501) P 4,000 (700) Cr S</p>	<p>ø22,0 x 66,2</p>	<p>G88601410S_1</p> <p>A= 88,540 B= 83,000 D= 97,000 F= 0,000 H= 95,140 L= 141,000</p> 		
<p>ø83,00</p> <p>4 Cyl. Benzin, 1905 cm³ 73 95 kW (99 129 hp) XU9JA <u>1985 - 1993</u></p> <p>205 1,9 GTI 309 1,9</p>	<p>18-7510360 STD Gömleklili Kodu 19-7510360 STD</p> 	<p>A = 37,500 B = 67,500 C = 9,000</p>	<p>RE47090000 -STD RE47090050 -0.50</p> <p>1,500 (500) CrB S IF 1,500 (501) P 4,000 (700) Cr S</p>	<p>ø22,0 x 66,2</p>	<p>G88601410S_1</p> <p>A= 88,540 B= 83,000 D= 97,000 F= 0,000 H= 95,140 L= 141,000</p> 		



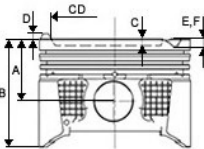
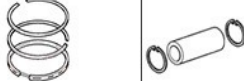



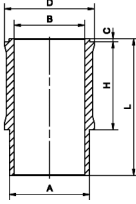

							
Motor /Engine	Ref. No. Kit 1	Ölçüler /Dimensions	Segman /Rings	Pim	Gömlek /Liner	Kit 2	Info
<p>ø83,00</p> <p>4 Cyl. Benzin, 1581 cm³ 53 59 kW (72 80 hp) XU51C XU92C</p> <p><u>1982 - 1990</u></p> <p>309 405</p>	<p>18-7510380 STD Gömleklili Kodu 19-7510380 STD</p>	<p>A = 37,500 B = 67,500 C = 3,000 CD= 73,800</p>	<p>RE47080000 -STD RE47080050 -0.50 RE47080080 -0.80</p> <p>1,750 (500) CrB S IF 1,750 (508) P 4,000 (700) Cr P S</p>	<p>ø22,0 x 66,2</p>	<p>G88601410S_1</p> <p>A= 88,540 B= 83,000 D= 97,000 F= 0,000 H= 95,140 L= 141,000</p> 		
<p>ø83,00</p> <p>4 Cyl. Benzin 1762 cc 74 76 KW101 103PS 9,25;1 XU7JPZ</p> <p><u>1992 - 2002</u></p> <p>306 1,8i 405 1,8i 806 1,8i</p>	<p>18-7510400 STD Gömleklili Kodu 19-7510400 STD</p> <p>18-7510403 0.50 Gömleklili Kodu 19-7510403 0.50</p>	<p>A = 33,300 B = 53,300 C = 4,200 CD= 67,700</p> <p>Sac Plaka (Steel Support)</p>	<p>RE47100000 -STD RE47100050 -0.50 RE47100080 -0.80</p> <p>1,500 (500) CrB Fe S IF 1,500 (501) P 3,000 (700) Cr P S</p>	<p>ø22,0 x 62,0</p>	<p>G88601410S_1</p> <p>A= 88,540 B= 83,000 D= 97,000 F= 0,000 H= 95,140 L= 141,000</p> 		



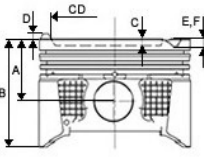







Motor /Engine	Ref. No. Kit 1	Ölçüler /Dimensions	Segman /Rings	Pim	Gömlek /Liner	Kit 2	Info
							
ø83,00 4 Cyl. Diesel, 1905 cm ³ 55 69 kW (75 94 PS) XUD9/A 1995 - 205 II 1.9D 306 1.9D 309 II 1.9D 405 II 1.9D Boxer 1.9D Partner 1.9D	18-7550450 STD 18-7550453 0.50 18-7550458 1.00	A = 46,800 B = 84,300 C = 2,200	RE47070000 -STD RE47070050 -0.50 RE47070060 -0.60 RE47070080 -0.80 RE47070100 -1.00 2,000 (500) CrB S 2,000 (501) P 3,000 (604) Cr P	ø25,0 x 72,0	G86001535K_1 A= 86,000 B= 83,000 D= 89,000 F= 5,000 H= 0,000 L= 153,500 		
ø83,00 4 Cyl. Diesel 1905 cc 51 Kw (69 Ps) 23,5:1 XUD9/A/L/Y 1996 - 205D GLD /GRD/XLD/XRD 305D/GLD/GRD/SRD Utilitaire 306/309D GLD/GRD/GTD/SRD XDT/XRD/X 405GLD/GRD/J5 Boxer Expert Partner	18-7550480 STD 18-7550483 0.50 18-7550488 1.00	A = 46,850 B = 84,250 C = 2,200 Segman Taşıyıcı (Ring Carrier)	RE47070000 -STD RE47070050 -0.50 RE47070060 -0.60 RE47070080 -0.80 RE47070100 -1.00 2,000 (500) CrB S 2,000 (501) P 3,000 (604) Cr P	ø25,0 x 70,4			

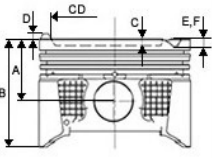







							
Motor /Engine	Ref. No. Kit 1	Ölçüler /Dimensions	Segman /Rings	Pim	Gömlek /Liner	Kit 2	Info
<p>ø83,00</p> <p>4 Cyl. Benzin 1905 cc 9,3:1 8v MPi XU9JA J1 J2 JAZ M <u>1986 - 1998</u></p> <p><i>19 Evasion XU911 (D6A) XUPJ2 (DFZ) 19 RI XU911 (D6A) XUPJ2 (DFZ) 19 RI XU91A (DDZ-DKZ) 19 TRI XU91A (DDZ-DKZ) 19GTI XU911 (D6A) XUPJ2 (DFZ) 19GTI XU91A (DDZ-DKZ) 19TRI XU911 (D6A) XUPJ2 (DFZ) BX 19 4W</i></p>	<p>18-7550490 STD</p>	<p>A = 37,500 B = 67,500 C = 8,900</p> <p>Sac Plaka (Steel Support)</p>	<p>RE47090000 -STD RE47090050 -0.50</p> <p>1,500 (500) CrB S IF 1,500 (501) P 4,000 (700) Cr S</p>	<p>ø22,0 x 66,2</p>			
<p>ø83,00</p> <p>4 Cyl. Diesel, 1905 cm³ 55 69 kW (75 94 PS) XUD9ATF XUD9BSD XUD9BTF <u>1993 - 2004</u></p> <p><i>306 1.9 TD 405 1.9 TD 406 1.9 TD 806 1.9 TD Boxer 1.9 TD Ducato 1.9 TD</i></p>	<p>18-7550910 STD 18-7550913 0.50 18-7550917 0.80</p>	<p>A = 46,750 B = 79,250 C = 3,500</p> <p>Sert Anotlama (Hard Anodising)</p>	<p>RE22250000 -STD RE22250050 -0.50 RE22250080 -0.80</p> <p>3,000 (504) Cr P 2,000 (501) P 3,000 (604) Cr P</p>	<p>ø28,0 x 68,0</p>			



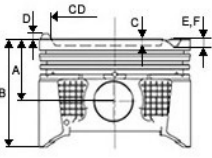





Motor /Engine	Ref. No. Kit 1	Ölçüler /Dimensions	Segman /Rings	Pim	Gömlek /Liner	Kit 2	Info
       							
ø83,00 4 Cyl. Diesel, 1905 cm ³ 55 69 kW (75 94 PS) XUD9ATF XUD9BSD XUD9 BTF <u>1992 - 2004</u> 306 1.9 TD 405 1.9 TD 406 1.9 TD 806 1.9 TD Boxer 1.9 TD Ducato 1.9 TD	18-7550920 STD 18-7550923 0.50	A = 46,750 B = 79,250 C = 3,500 Segman Taşıyıcı (Ring Carrier) Sert Anotlama (Hard Anodising) Yag Püskürt. Oyugu (Oil Cut-Out)	RE47230000 -STD RE47230050 -0.50 RE47230080 -0.80 3,500 (504) Cr 2,000 (501) P 3,000 (604) Cr P	ø28,0 x 68,0			
ø84,00 4 Cyl. Benzin1796cc 49 51kW(69 PS) 7,5:1,8 VentileC25 1.8 169 (XM7T) <u>07/87-02/94</u> C25 1.8 E C25 1.8E7/87-2/94 DUCATO 1.8 1/82-10/88 504 1.8 1/71-12/89 505 1.8 6/81-10/85 J5 1.8 1/83-11/88 7/70-3/80	18-7510020 STD Gömleklı Kodu 19-7510020 STD	A = 37,800 B = 70,250	RE22280000 -STD 1,500 (500) Cr S IF 2,000 (508) P 4,000 (700) Cr P S	ø23,0 x 70,0	G93001362S_1 A= 93,000 B= 84,000 D= 99,200 F= 0,000 H= 90,000 L= 136,200		



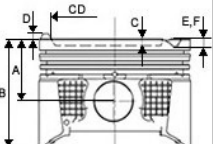





							
Motor /Engine	Ref. No. Kit 1	Ölçüler /Dimensions	Segman /Rings	Pim	Gömlek /Liner	Kit 2	Info
<p>ø84,00</p> <p>4 Cyl. Benzin, 1796 cm³ 48 58 kW (65 79 hp) 7,5:1 XM7 KF5 KF6 <u>1971 - 1981</u></p> <p>504 505 J7 J9 1986></p>	<p>18-7510030 STD Gömleklili Kodu 19-7510030 STD</p>	<p>A = 37,300 B = 70,300 D = 1,000</p>	<p>RE47120000 -STD</p> <p>1,500 (500) CrS IF 25,000 (508) P 4,000 (700) Cr P S</p>	<p>ø23,0 x 70,0</p>	<p>G93001362S_1</p> <p>A= 93,000 B= 84,000 D= 99,200 F= 0,000 H= 90,000 L= 136,200</p>		
<p>ø85,00</p> <p>4/6 Cyl. Diesel 2179 cc 110 KW 211 PS DW12BTED4 <u>2011 - 2013</u> FREELANDER 2 2.2 TD4</p>	<p>17-6592300 STD 17-6592303 0.50</p>	<p>A = 48,705 B = 74,705 C = 13,475 E = -0,385 CD= 52,400</p> <p>Segman Taşıyıcı (Ring Carrier)</p> <p>Yag Galerisi (Oil Gallery)</p> <p>Yag Püskürt. Oyugu (Oil Cut-Out)</p>	<p>RE35000000 -STD RE35000050 -0.50</p> <p>2,500 (505) Cr P 2,000 (501) P IFU 2,000 (604) Nit S</p>	<p>ø30,0 x 68,0</p>			
							



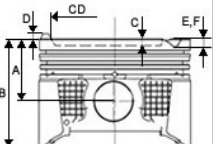



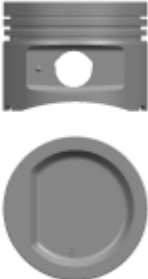
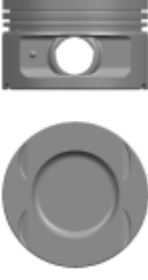

							
Motor /Engine	Ref. No. Kit 1	Ölçüler /Dimensions	Segman /Rings	Pim	Gömlek /Liner	Kit 2	Info
<p>ø85,00</p> <p>4 Cyl. Benzin 2000 cc 100/105 kW 136/1436 PS EW10J B</p> <p>..... -</p> <p>307 206 EXPEERT 407 607 406 806</p>	<p>18-7510750 STD</p> <p>18-7510752 0.40</p> <p>18-7510754 0.60</p>	<p>A = 29,000</p> <p>B = 51,000</p> <p>C = 0,750</p> <p>CD= 48,000</p>	<p>RE18500000 -STD</p> <p>RE18500040 -0.40</p> <p>RE18500050 -0.50</p> <p>RE18500060 -0.60</p> <p>RE18500080 -0.80</p> <p>1,200 (500) Nit S IF</p> <p>1,500 (508) P</p> <p>2,500 (700) Nit S</p>	<p>ø21,0 x 68,0</p>			
<p>ø85,00</p> <p>4 Cyl. Diesel 1997 cc 103 kW 140PS EW10A RFJ</p> <p>2004 -</p> <p>307 308 407 2,0 16V</p>	<p>18-7510760 STD</p> <p>18-7510763 0.50</p>	<p>A = 29,000</p> <p>B = 51,150</p> <p>D = 0,150</p> <p>E = -3,700</p>	<p>RE18500000 -STD</p> <p>RE18500040 -0.40</p> <p>RE18500050 -0.50</p> <p>RE18500060 -0.60</p> <p>RE18500080 -0.80</p> <p>1,200 (500) Nit S IF</p> <p>1,500 (508) P</p> <p>2,500 (700) Nit S</p>	<p>ø21,0 x 56,0</p>			



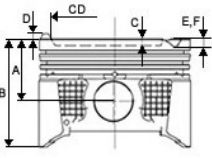



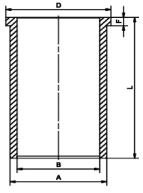
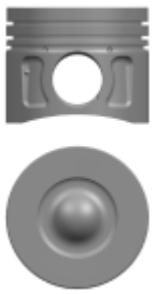

Motor /Engine	Ref. No. Kit 1	Ölçüler /Dimensions	Segman /Rings	Pim	Gömlek /Liner	Kit 2	Info
       							
ø85,00 4 Cyl. Diesel 2088 cc 81 Kw (110 Ps) 21,5:1 XUD11BTE 1995 -.... 406 2.1TD 605 2.1TD 806 2.1TD	18-7550880 STD 18-7550884 0.60	A = 44,900 B = 74,700 C = 2,400 Segman Taşıyıcı (Ring Carrier) Sert Anotlama (Hard Anodising) Yag Galerisi (Oil Gallery) Yag Püskürt. Oyugu (Oil Cut-Out)	RE47240000 -STD RE47240050 -0.50 RE47240060 -0.60 3,000 (504) Cr P 2,000 (501) P 3,000 (604) Cr P	ø30,0 x 68,0			1.52 mm conta 0,65 0,75 1.57 mm conta 0,77 0,81 1.62 mm conta 0,82 0,86
ø85,00 Turbo Intercooler 3 Valf DW12TD/TED 2002 -.... 607 HDI 406 HDI Boxer 330M/330C/290C 2,2 HDI	18-7550890 STD 18-7550894 0.60	A = 48,700 B = 77,700 C = 17,700 E = -1,200 CD= 42,000 Segman Taşıyıcı (Ring Carrier) Yag Püskürt. Oyugu (Oil Cut-Out)	RE47440000 -STD RE47440060 -0.60 3,500 (505) Cr P 2,000 (501) P IFU 3,000 (604) Cr P	ø30,0 x 68,0		 	



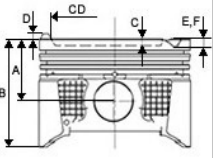



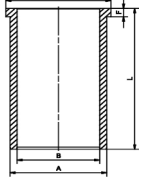
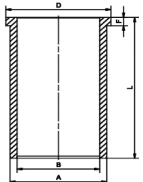

Motor /Engine	Ref. No. Kit 1	Ölçüler /Dimensions	Segman /Rings	Pim	Gömlek /Liner	Kit 2	Info
       							
ø85,00 4 Cyl. Diesel 1997/1998 cc 79/80/81/100Kw 90/107/109Ps 110/136 Ps DW10ATED TD10ATED DW10TD Euro 3 G6DB RHS RHW RHX RHY RHZ D420 4T <u>1998 -</u> 2.0 HDI 206/306/307/406 Boxer Partner Expet C5 Jumpy Xsara Scudo 2.0JTD Cmax Focus II Grand Vitara C30 C70 S40/80 II V50 V70 III TDI	18-7550900 STD 18-7550900-20 STD (-0.20 mm) 18-7550900-40 STD (-0.40 mm) 18-7550903 0.50 18-7550904 0.60	A = 46,750 B = 80,750 C = 18,300 E = -1,000 CD= 38,000 Segman Taşıyıcı (Ring Carrier) Yag Püskürt. Oyugu (Oil Cut-Out)	RE47440000 -STD RE47440060 -0.60 3,500 (505) Cr P 2,000 (501) P IFU 3,000 (604) Cr P	ø28,0 x 70,0			1,25 mm conta +0,55 + 0,60 1,30 mm conta +0,61 +0,65 1,35 mm conta +0,66 +0,70 1,40 mm conta +0,71 +0,75
ø85,00 4 Cyl. Diesel, 1997 cm ³ 62 88 kW (84 120 PS) DW10BTED4 <u>1999 - 2007</u> (2.0HDI) Berlingo C4 16V C4 GrandPicasso 16V C4 Picasso 16V C5 16V C8 16V Jumpy 6V C-Max Kuga 307 16V 307 CC 16V 308 16V 407 16V 508	18-7551920 STD 18-7551924 0.60	A = 46,705 B = 80,705 C = 15,400 E = -0,520 CD= 44,800 Segman Taşıyıcı (Ring Carrier) Yag Galerisi (Oil Gallery) Yag Püskürt. Oyugu (Oil Cut-Out)	RE47440000 -STD RE47440060 -0.60 3,500 (505) Cr P 2,000 (501) P IFU 3,000 (604) Cr P	ø28,0 x 70,0			



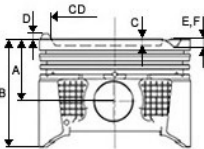



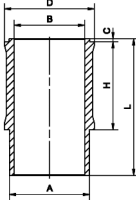
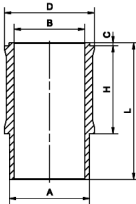

Motor /Engine	Ref. No. Kit 1	Ölçüler /Dimensions	Segman /Rings	Pim	Gömlek /Liner	Kit 2	Info
							
ø85,00 4 Cyl. Diesel 1997 cc 163PS DW10CTED4 2009 - 3008 5008 C4 C5 III 2.0 HDI DS4 KUGA	18-7592960 STD 18-7592964 0.60	A = 46,705 B = 74,705 C = 13,710 E = -0,455 CD= 50,400 Segman Taşıyıcı (Ring Carrier) Yag Galerisi (Oil Gallery) Yag Püskürt. Oyugu (Oil Cut-Out)	RE47770000 -STD RE47770060 -0.60 2,000 () 2,000 () P 2,000 ()	ø30,0 x 68,0			
ø85,00 4 Cyl. Diesel 1997 cc 81/88/100/110 130/132133 KW 110/120/136/150 179/181 PS AHH/J/M/NP/T/U/X EHS/T/W/Y/Z D20 DTH/L/R DW10FC/E/UE/UD/CD FDCC/CU/DDU Euro 5 2009 - 5008/508/508 SW 2.0 Hdi 136 BlueHdi 136/180/150 3008/Blue 2.0 Hdi 150 5008/Blue 2.0 Hdi 150	18-7592970 STD 18-7592974 0.60	A = 46,600 B = 72,000 C = 12,710 CD= 51,300 Segman Taşıyıcı (Ring Carrier) Yag Galerisi (Oil Gallery)	RE47770000 -STD RE47770060 -0.60 2,000 () 2,000 () P 2,000 ()	ø30,0 x 68,0			



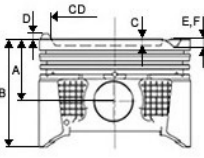



Motor /Engine	Ref. No. Kit 1	Ölçüler /Dimensions	Segman /Rings	Pim	Gömlek /Liner	Kit 2	Info
       							
ø86,00 4 Cyl. Benzin 1998 cc 88 Kw (121 Ps) XU10J2 XU10J2 TE XU 10J2 Z 1993 -..... Dizel 2446 cc Boxer 2,5 D 1996	18-7510860 STD 18-7510863 0.50 18-7510864 0.60	A = 40,000 B = 64,850 C = 5,000	RE47130000 -STD RE47130025 -0.25 RE47130050 -0.50 RE47130060 -0.60 1,500 (500) CrB S 1,750 (508) P 3,000 (700) Cr P S	ø22,0 x 62,0			
							
ø86,00 4 Cyl. Benzin, 1998 cm ³ 98 kW (133 hp) XU10J4R 1995 -..... 206 306 307 406 Boxer Partner	18-7510870 STD 18-7510873 0.50 18-7510874 0.60	A = 33,800 B = 53,800 C = 4,300 E = -1,700 F = -2,000 CD= 52,000 Yag Püskürt. Oyugu (Oil Cut-Out)	RE47130000 -STD RE47130025 -0.25 RE47130050 -0.50 RE47130060 -0.60 1,500 (500) CrB S 1,750 (508) P 3,000 (700) Cr P S	ø22,0 x 62,0			
							

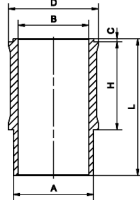



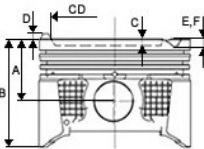
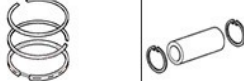



Motor /Engine	Ref. No. Kit 1	Ölçüler /Dimensions	Segman /Rings	Pim	Gömlek /Liner	Kit 2	Info
							
ø86,00 4 Benzin, 1998 cm ³ 120 kW (163 PS) 10:1 16 Ventile RFS (XU10J4RS) 05/1996 - 03/2005 XSARA 2.0 I ZSARA 2.0 16 ZX 2.0 I	18-7510900 STD 18-7510904 0.60	A = 33,900 B = 58,400 C = 2,000 E = -1,740 F = -1,350 CD= 71,920 Yag Püskürt. Oyugu (Oil Cut-Out)	RE43190000 -STD RE43190050 -0.50 RE43190100 -1.00 1,500 (500) CrB S 1,500 (501) P 3,000 (700) Cr P S	ø22,0 x 62,0			
ø86,01 4 Cyl. Diesel 2198/2200 cc 100/120/130/150 Ps 17,5:1 QWFB/V347 Duratorq Euro 4 Duratorq/V347 D CD132 Duratorq TDCI 2003/2008.. Common Rail Transit 2.2 TDCI Yeni Jumper 2.2 HDI Ducato 100 Multijet Yeni Boxer HDI Mondeo 2.2 TDCI Transit 2.2 TDCI	18-2582350 STD 18-2582350-20 STD (-0.20 mm) 18-2582351 0.25 18-2582353 0.50 18-2582353-20 0.50 (-0.20 mm)	A = 43,420 B = 69,820 C = 15,850 CD= 46,900 Segman Taşıyıcı (Ring Carrier) Yag Galerisi (Oil Gallery)	RE23350000 -STD RE23350025 -0.25 RE23350050 -0.50 2,000 (500) Cr P IF 2,000 (508) P 2,000 (604) Nit S	ø30,0 x 66,9	G86011560K_1 A= 89,000 B= 85,310 D= 90,500 F= 5,000 H= 0,000 L= 156,000 	1,10 mm conta +0,38 +0,47 1,20 mm conta +0,48 +0,58 1,30 mm conta + 0,59 +0,68	



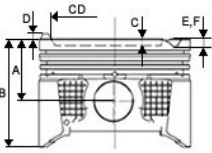





Motor /Engine	Ref. No. Kit 1	Ölçüler /Dimensions	Segman /Rings	Pim	Gömlek /Liner	Kit 2	Info
							
ø86,01 4 Cyl. Diesel 2198/2179 cc 155 PS 74 Kw (100 Ps) 15,5:1 2.2L Duratorg/HDI (CUFF,CUF5,CVR5,UYRG) 2002 - Euro 5 TRANSİT 2.2 (YENİ) Boxer 2.2L	18-2582420 STD 18-2582420-20 STD (-0.20 mm) 18-2582421 0.25 18-2582423 0.50 18-2582423-20 0.50 (-0.20 mm)	A = 48,420 B = 74,820 C = 18,230 CD= 49,040 Segman Taşıyıcı (Ring Carrier) Yag Galerisi (Oil Gallery) Yag Püskürt. Oyugu (Oil Cut-Out)	RE23350000 -STD RE23350025 -0.25 RE23350050 -0.50 2,000 (500) Cr P IF 2,000 (508) P 2,000 (604) Nit S	ø30,0 x 66,9	G86011650K_1 A= 89,000 B= 85,310 D= 90,500 F= 5,000 H= 0,000 L= 165,000 		
ø86,01 4 Cyl. Diesel 2198/2179 cc 155 PS 74 Kw (100 Ps) 15,5:1 2.2L Duratorg/HDI (CUFF,CUF5,CVR5,UYRG) 2002 - Euro 5 Boxer 2.2L	18-7592950 STD 18-7592950-20 STD (-0.20 mm) 18-7592951 0.25 18-7592953 0.50 18-7592953-20 0.50 (-0.20 mm)	A = 48,420 B = 74,820 C = 18,230 CD= 49,040 Segman Taşıyıcı (Ring Carrier) Yag Galerisi (Oil Gallery) Yag Püskürt. Oyugu (Oil Cut-Out)	RE23350000 -STD RE23350025 -0.25 RE23350050 -0.50 2,000 (500) Cr P IF 2,000 (508) P 2,000 (604) Nit S	ø30,0 x 66,9	G86011650K_1 A= 89,000 B= 85,310 D= 90,500 F= 5,000 H= 0,000 L= 165,000 		



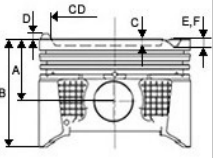





							
Motor /Engine	Ref. No. Kit 1	Ölçüler /Dimensions	Segman /Rings	Pim	Gömlek /Liner	Kit 2	Info
<p>ø88,00</p> <p>4 Cyl. Benzin 1971 cc 57 Kw (78 Ps) XN1P XNA XN1T XN2/3</p> <p><u>1971 - 1993</u></p>	<p>18-7510200 STD Gömleklili Kodu 19-7510200 STD</p> <p>18-7510203 0.50 Gömleklili Kodu 19-7510203 0.50</p>	<p>A = 38,250 B = 71,850 D = 0,650</p>	<p>RE47160000 -STD RE47160050 -0.50</p> <p>1,500 (500) Cr 2,000 (501) 4,000 (700) Cr P S</p>	<p>ø23,0 x 74,1</p>	<p>G93001356S_1</p> <p>A= 93,000 B= 88,000 D= 101,900 F= 0,000 H= 90,000 L= 135,600</p> 		
<p>ø88,00</p> <p>4 Cyl. Benzin 1971 cc 57 Kw (78 Ps) XN1T XN1 XN2</p> <p><u>1971 - 1993</u></p> <p>J5 J9 504</p>	<p>18-7510220 STD Gömleklili Kodu 19-7510220 STD</p>	<p>A = 37,900 B = 65,450 D = 2,550</p>	<p>RE47160000 -STD RE47160050 -0.50</p> <p>1,500 (500) Cr 2,000 (501) 4,000 (700) Cr P S</p>	<p>ø23,0 x 74,1</p>	<p>G93001356S_1</p> <p>A= 93,000 B= 88,000 D= 101,900 F= 0,000 H= 90,000 L= 135,600</p> 		



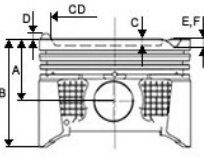





							
Motor /Engine	Ref. No. Kit 1	Ölçüler /Dimensions	Segman /Rings	Pim	Gömlek /Liner	Kit 2	Info
<p>ø88,00</p> <p>4 Cyl. Diesel 1975/1987/1990 cc 32/40/42/44 Kw (49/54/5760 Ps) VTA XDP4.88 XD 4.88 XD 88 XD P 4.88/4.88/88</p> <p><u>1987</u></p> <p>504 1.9D 404 1.9D 404 2.0D/504 2.0D J 7 1.9 D Granada 2.0D</p>	<p>18-7550930 STD</p>	<p>A = 58,700 B = 95,700 C = 1,950</p>	<p>RE47140000 -STD</p> <p>2,000 (500) Cr 2,000 (501) P 2,000 (508) P 4,500 (604) P</p>	<p>ø28,0 x 72,0</p>			
<p>ø90,00</p> <p>4 Cyl. Diesel 2112 cc 46/43/48/55/78 Kw (59/63/56/75/95/106 Ps) XD4.90 XDP4.90 XDP6.90WTA</p> <p><u>1969....</u></p> <p>J 7 2.1 D 504 2.1 D J 9 2.1 D J 7 2.1 D Granada 2.1 D Blitz 2.1 D</p>	<p>18-7550940 STD Gömleklı Kodu 19-7550940 STD</p> <p>18-7550943 0.50 Gömleklı Kodu 19-7550943 0.50</p> <p>18-7550948 1.00 Gömleklı Kodu 19-7550948 1.00</p>	<p>A = 57,200 B = 96,350 C = 2,000</p>	<p>RE47170000 -STD RE47170050 -STD RE47170100 -STD</p> <p>2,000 (500) Cr 2,000 (501) P 2,000 (508) P 4,500 (604) P</p>	<p>ø28,0 x 77,0</p>	<p>G96001733S_1</p> <p>A= 96,000 B= 90,000 D= 106,300 F= 0,000 H= 129,050 L= 173,350</p> 		

							
Motor /Engine	Ref. No. Kit 1	Ölçüler /Dimensions	Segman /Rings	Pim	Gömlek /Liner	Kit 2	Info
<p>ø92,00</p> <p>4 Cyl. Diesel 2446 cc DJ5 <u>1996 -....</u> Boxer 2,5 D</p>	<p>18-7550530 STD 18-7550533 0.50</p>	<p>A = 49,740 C = 1,750</p>	<p>RE47500000 -STD RE47500050 -0.50</p> <p>2,250 (500) Cr P 2,000 (508) P 3,000 (604) Cr P</p>	<p>ø34,0 x 58,0</p>			<p>+ 0,40 + 0,60</p>
<p>ø92,00</p> <p>4 Cyl. Diesel 2446 cc DJ5TDI TED <u>1997 -....</u> Boxer 2,5 TD</p>	<p>18-7589220 STD 18-7589223 0.50</p>	<p>A = 57,000 B = 89,000 C = 18,250 E = -1,500 CD= 41,000</p> <p>Segman Taşıyıcı (Ring Carrier)</p> <p>Yag Galerisi (Oil Gallery)</p>	<p>RE47520000 -STD RE47520050 -0.50</p> <p>3,500 (505) MoB N 2,000 (508) P 3,500 (604) Cr P</p>	<p>ø34,0 x 68,0</p>			<p>1,30 mm conta + 0,50 + 0,60</p>

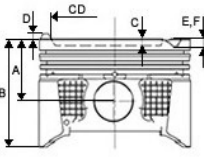







Motor /Engine	Ref. No. Kit 1	Ölçüler /Dimensions	Segman /Rings	Pim	Gömlek /Liner	Kit 2	Info
       							
ø92,00 4 Cyl. 2446 cc 76 96 Kw (103 130 Ps) Turbo DJ5T <u>1997 -....</u> Boxer 2,5 T Citroen Jumper 2,5 T	18-7589330 STD 18-7589333 0.50	A = 49,840 C = 2,300 Segman Taşıyıcı (Ring Carrier) Sert Anotlama (Hard Anodising) Yag Galerisi (Oil Gallery)	RE47310000 -STD RE47310050 -0.50 3,000 (504) MoB N IF 1,750 (501) Cr IF 3,500 (604) Cr P	ø34,0 x 68,0			+ 0,64 + 0,74
ø93,03 4 Cyl. Diesel 2498cc 54 kW (73 PS) 4JB1 <u>1981 - 1994</u> Karsan J9 Premier	18-7550870 STD	A = 51,850 B = 91,850 C = 19,500 E = -0,550 CD= 43,900 Segman Taşıyıcı (Ring Carrier) Sac Plaka (Steel Support) Yag Püskürt. Oyugu (Oil Cut-Out)	RE47420000 -STD RE47420050 -0.50 2,000 (500) Cr P 2,000 (508) P 4,000 (604) Cr P	ø31,0 x 76,0			0 + 0,70



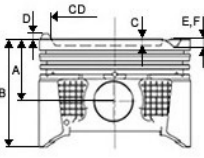



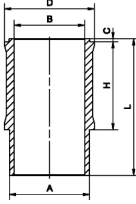

Motor /Engine	Ref. No. Kit 1	Ölçüler /Dimensions	Segman /Rings	Pim	Gömlek /Liner	Kit 2	Info
							
ø94,40 4 Cyl. Diesel 2798 cc 64 Kw (87 Ps) Sofim Motor 8140.63.3700 1998 - 1999 Ducato 14 2.8 D Ducato Maxi 2.8D	18-2051130 STD 18-2051132 0.40 18-2051134 0.60	A = 55,000 B = 90,000 C = 1,700 Segman Taşıyıcı (Ring Carrier) Sert Anotlama (Hard Anodising) Yag Püskürt. Oyugu (Oil Cut-Out)	RE22790000 -STD RE22790040 -0.40 RE22790060 -0.60 3,000 (504) Cr P 2,000 (501) P IWU 2,500 (604) Cr P	ø32,0 x 68,0			+ 0,40 + 0,50 (1.20 mm Conta) + 0,51 + 0,60 (1.30 mm Conta) + 0,61 + 0,70 (1.40 mm Conta)
ø94,40 4 Cyl. Diesel 2798 cc 107 Kw (146 Ps) 18 5:1 SOFIM 8140.43S.4000 Euro 3 8140.23.2585/3700 Euro 3 8140.63.3700 8140.43M. 4300/4320/4330 Euro 3 2000-.... Ducato 2.8 JTD 35C.15/35S.15/50C.15 60C.15 TD/65C.15 65C.13 Daily Unijet Boxer 2.8 HDI	18-2081440 STD 18-2081440-20 STD (-0.20 mm) 18-2081442 0.40 18-2081442-20 0.40 (-0.20 mm) 18-2081444 0.60 18-2081444-20 0.60 (-0.20 mm)	A = 58,700 B = 87,600 C = 21,300 CD= 39,500 Segman Taşıyıcı (Ring Carrier) Yag Galerisi (Oil Gallery) Yag Püskürt. Oyugu (Oil Cut-Out)	RE22780000 -STD RE22780040 -0.40 RE22780060 -0.60 2,500 (504) Cr P 2,000 (501) P 2,500 (604) Cr P	ø32,0 x 72,0			1,20 mm conta + 0,40 + 0,50 1,30 mm conta + 0,51 + 0,60 1,40 mm conta + 0,61 + 0,70 1,50 mm conta + 0,71 + 0,80



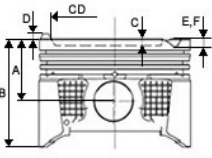



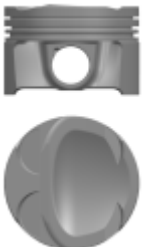

							
Motor /Engine	Ref. No. Kit 1	Ölçüler /Dimensions	Segman /Rings	Pim	Gömlek /Liner	Kit 2	Info
<p>ø95,80</p> <p>4 Cyl. Diesel 2998 cc 156 PS18:01 T3.0 F1C/HDI EURO 5</p> <p>.... -</p> <p>JUMPER</p>	<p>18-2092980 STD</p> <p>18-2092982 0.40</p>	<p>A = 63,000</p> <p>B = 93,400</p> <p>C = 16,000</p> <p>CD= 53,200</p> <p>Segman Taşıyıcı (Ring Carrier)</p> <p>Yag Galerisi (Oil Gallery)</p> <p>Yag Püskürt. Oyugu (Oil Cut-Out)</p>	<p>RE22870000 -STD</p> <p>RE22870040 -0.40</p> <p>2,500 (504) Cr P</p> <p>2,000 (501) P</p> <p>2,500 (604) P</p>	<p>ø36,0</p> <p>x 80,8</p>			



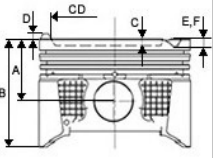







							
Motor /Engine	Ref. No. Kit 1	Ölçüler /Dimensions	Segman /Rings	Pim	Gömlek /Liner	Kit 2	Info
<p>ø69,00</p> <p>4 Cyl. Benzin 1149 cc 44 Kw (60 Ps) D7F F4P 44KW 700/701/702 706/710/720/ <u>1996 -....</u></p> <p><i>Clio 1.2i Kangoo 1.2i Twingo 1.2i</i></p>	<p>18-8010040 STD 18-8010043 0.50</p>	<p>A = 27,150 B = 50,500</p>	<p>RE49330000 -STD RE49330050 -0.50</p> <p>1,500 (500) Cr P IF 1,500 (501) P IFU 2,500 (604) Cr P</p>	<p>ø17,0 x 53,7</p>			
<p>ø69,00</p> <p>4 Cyl. Benzin 1149cc 55 kW 75PS9;8 BİYEL KOLU İKİ GEÇME D4F 732 734 <u>2012</u></p> <p><i>Clio 1.2 16V</i></p>	<p>18-8011030 STD 18-8011033 0.50</p>	<p>A = 26,800 B = 44,800 C = 1,100 CD= 61,000</p>	<p>RE49520000 -STD RE49520050 -0.50</p> <p>1,200 (500) Nit S 1,500 (501) P IF 2,500 (700) Cr P S</p>	<p>ø17,0 x 53,7</p>			

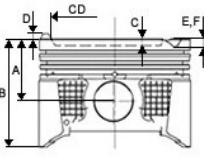





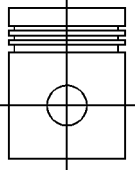
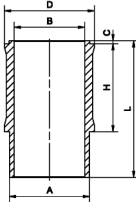

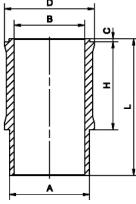



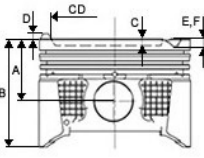



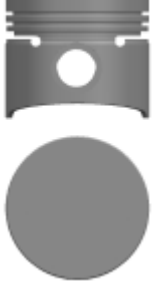
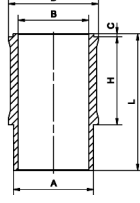
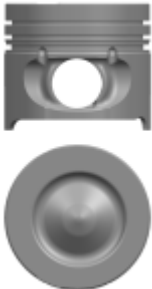
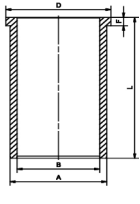

							
Motor /Engine	Ref. No. Kit 1	Ölçüler /Dimensions	Segman /Rings	Pim	Gömlek /Liner	Kit 2	Info
<p>ø69,00</p> <p>4 Cyl. Benzin 1200cc 75 BİYEL KOLU İKİ GEÇME D4F 740 <u>1993 - 2009</u></p> <p><i>Clio II Clio III Modus Twingo</i></p>	<p>18-8011040 STD 18-8011043 0.50</p>	<p>A = 26,700 B = 44,700 C = 1,100 CD= 60,300</p>	<p>RE49520000 -STD RE49520050 -0.50</p> <p>1,200 (500) Nit S 1,500 (501) P IF 2,500 (700) Cr P S</p>	<p>ø17,0 x 53,7</p>			
<p>ø70,00</p> <p>4 Cyl. Benzin 1108 cc 39 Kw (53 Ps) 688.01 688.02 688.06 688.09 688.10 688.11 688.12 6 <u>1976 - 1990</u></p> <p><i>R4 R5 R6 R8 R9 R10 R11</i></p>	<p>18-8010050 STD Gömleklı Kodu 19-8010050 STD</p>	<p>A = 40,000 B = 68,000</p>	<p>RE49030000 -STD</p> <p>1,750 (500) Cr S IF 2,000 (501) P 3,500 (700) Cr P S</p>	<p>ø18,0 x 62,0</p>	<p>G75501350S_1</p> <p>A= 75,500 B= 70,000 D= 85,750 F= 0,000 H= 94,800 L= 135,000</p>		



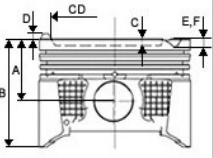





Motor /Engine	Ref. No. Kit 1	Ölçüler /Dimensions	Segman /Rings	Pim	Gömlek /Liner	Kit 2	Info
							
ø72,20 4 Cyl. Benzin 1332 cc 120 135kW 163 184 PS M 282.194 H5H 450/470/480/490 <u>2018 -</u> CAPTUR I (J5_H5_HF) 1.3 Tce CLIO V (B7_) 1.3 Tce GRAND SCENIC IV KADJAR (HA_HL_HC) 1.3 Tce MEGANE IV Grandtour MEGANE IV Sedan/Hatchback SCENIC IV TALISMAN LODGY (J5_) 1.3 Tce DUSTER (FM_) 1.3 Tce	18-8010020 STD 18-8010023 0.50	A = 31,550 B = 49,050 C = 5,100 E = -3,250 F = -3,850 CD= 47,300 Segman Taşıyıcı (Ring Carrier)	RE49580000 -STD RE49580050 -0.50 1,200 (500) IFU NIT S 1,500 (508) Cr P 2,000 (700) NIT S	ø20,0 x 47,0			
ø72,20 3/4 Cyl. Benzin 898/999 1197 cc 51/56/66/ 84/85/74/83/85/97 87/88/96kW 96/113/116 118/120/130HP H5F 400/403/408 402/404/412 1.2 TCE <u>2013/06 -....</u> CAPTUR (J5_H5) H4B-H4D DFAC 1.2 Tce 120/1.2 T QASHQAI	17-8010060 STD 17-8010063 0.50	A = 31,300 B = 48,400 C = 4,800 E = -2,600 F = -2,000 CD= 1,100 Segman Taşıyıcı (Ring Carrier)	RE49580000 -STD RE49580050 -0.50 1,200 (500) IFU NIT S 1,500 (508) Cr P 2,000 (700) NIT S	ø20,0 x 49,0			
							



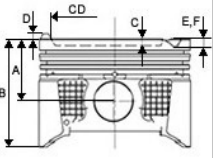





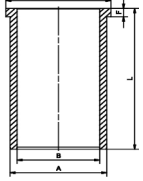
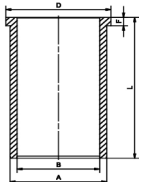

Motor /Engine	Ref. No. Kit 1	Ölçüler /Dimensions	Segman /Rings	Pim	Gömlek /Liner	Kit 2	Info
       							
ø72,20 3 Cyl. Benzin 898/999 cc 56/66 kW 76/90 PS H4B 400/401/408/453 <u>2012 -....</u> III TWINGO SYMBOL SCENIC MEGANE KANGOO GRANDTORU CAPTUR SANDERO II LOGAN MCV II LOGY JOGGER CLIO IV STEPAY	17-8010070 STD 17-8010073 0.50	A = 31,300 B = 48,800 C = 4,600 E = -0,800 F = -3,400 CD= 61,900 Sert Anotlama (Hard Anodising)	RE49580000 -STD RE49580050 -0.50 1,200 (500) IFU NIT S 1,500 (508) Cr P 2,000 (700) NIT S	ø20,0 x 43,3			
							
ø73,00 4 Cyl. Benzin 1289 cc 40 Kw (54 Ps) 9,5:1 810.05 <u>1971 - 1989</u> R12	18-8010080 STD	A = 37,610 B = 62,500 C = 1,600 CD= 50,000	RE49050000 -STD 1,750 (500) Cr S 2,000 (508) P 4,000 (700) Cr P S	ø20,0 x 64,0			

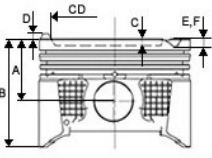



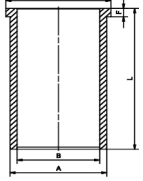
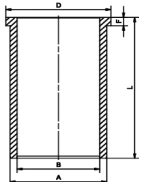
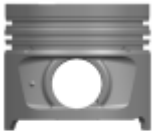

							
Motor /Engine	Ref. No. Kit 1	Ölçüler /Dimensions	Segman /Rings	Pim	Gömlek /Liner	Kit 2	Info
<p>ø73,00</p> <p>4 Cyl. Benzin 1289 cc 44 50 Kw (60 68 Ps) 810. 810.01 810.02 810.03 810.05 810.10 810.19 810 <u>1971 - 1984</u></p> <p>R5 R10 R12 R15</p> 	<p>18-8010090 STD Gömleklili Kodu 19-8010090 STD</p>	<p>A = 37,500 B = 62,500</p>	<p>RE49050000 -STD</p> <p>1,750 (500) Cr S 2,000 (508) P 4,000 (700) Cr P S</p>	<p>ø20,0 x 64,0</p>	<p>G78451340S_1</p> <p>A= 78,450 B= 73,000 D= 88,000 F= 0,000 H= 94,850 L= 134,000</p> 		
<p>ø75,80</p> <p>4 Cyl. Benzin 1390 cc 55 59 Kw (75 80 Ps) E7J (720/724/726/728/773) E6JA700 <u>1988 -....</u></p> <p>Clio 1.4 R 19 1.4 Clio RN-RT Express Kangoo 1.4i R 19 RN-RT-Rti R 19 RL R12 1.4</p> 	<p>18-8010180 STD Gömleklili Kodu 19-8010180 STD</p>	<p>A = 31,700 B = 52,700</p> <p>Sac Plaka (Steel Support)</p>	<p>RE49260000 -STD</p> <p>1,500 (500) CrB Fe S IF 1,750 (501) P 3,000 (700) Cr P S</p>	<p>ø19,0 x 60,0</p>	<p>G80601300S_1</p> <p>A= 80,600 B= 75,800 D= 90,200 F= 0,000 H= 91,500 L= 130,000</p> 		





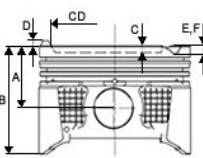
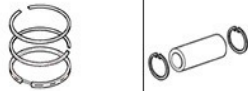

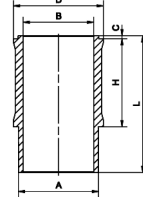

							
Motor /Engine	Ref. No. Kit 1	Ölçüler /Dimensions	Segman /Rings	Pim	Gömlek /Liner	Kit 2	Info
<p>ø76,00</p> <p>4 Cyl. Benzin 1397 cc 43 53 Kw (59 72 Ps) C1/2/3/16 J B14 B14 OE 847 700/720 847.2 715/717/742/768 <u>1981 - 1998</u> R18/5/19/21 R12 TSW/TX TOROS R9 BVA AUTOMOTIC R9 GTE BRODWAY/SPRING FUEGO RAPID EXPRESS TRAFFIC VOLVO 340/343/345</p>	<p>18-8010190 STD Gömlikli Kodu 19-8010190 STD</p> 	<p>A = 37,500 B = 64,000</p>	<p>RE49070000 -STD RE49070050 -0.50</p> <p>1,750 (500) Cr S IF 2,000 (508) P 4,000 (700) Cr P S</p>	<p>ø20,0 x 64,0</p>	<p>G80551340S_1</p> <p>A= 80,600 B= 76,000 D= 90,100 F= 0,000 H= 95,000 L= 134,150</p> 		<p>O-Ring Bilgi</p> <p>04x 77,2x1,25</p>
<p>ø76,00</p> <p>4 Cyl. Diesel 1461cc 65 KW 90 HP K9K Euro5 OM607 <u>2010 -....</u> Grand Scenic III 1.5DCI 16V Megane Grandtour III 1.5dCi Megane III 1.5dCi Citane 108/109 A 160 CDI B160 CDI</p>	<p>18-8050840 STD <i>18-8050840-20 STD (-0.20 mm)</i> 18-8050843 0.50 <i>18-8050843-20 0.50 (-0.20 mm)</i> 18-8050848 1.00 <i>18-8050848-20 1.00 (-0.20 mm)</i></p> 	<p>A = 41,667 B = 66,000 C = 13,500 E = -0,250 F = -0,430 CD= 47,000</p> <p>Segman Taşıyıcı (Ring Carrier)</p> <p>Yağ Püskürt. Oyugu (Oil Cut-Out)</p>	<p>RK80207600010 -STD RK80207600013 -0.50 RK80207600018 -1.00</p> <p>2,000 (500) CKP 2,000 (501) P 2,500 (604) CrP</p>	<p>ø26,0 x 60,0</p>	<p>G79601420K_1</p> <p>A= 79,600 B= 75,300 D= 81,500 F= 5,500 H= 0,000 L= 142,000</p> 		



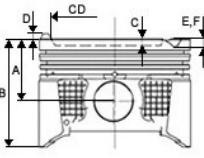







Motor /Engine	Ref. No. Kit 1	Ölçüler /Dimensions	Segman /Rings	Pim	Gömlek /Liner	Kit 2	Info
       							
ø76,00 4 Cyl. Diesel 1500 cc 65 PsCommon Rail K9K 2002 -..... Clio Symbol 1.5dci Kangoo 1.5 dci Duster 1.5 dci Logan 1.5 dci Logan Epress 1.5 dci Logan MCV 1.5 dci Logan Pickup 1.5 dci Sandero 1.5 dci	18-8050850 STD 18-8050853 0.50	A = 41,700 B = 66,000 C = 14,000 E = -0,430 F = -0,250 CD= 39,700 Segman Taşıyıcı (Ring Carrier) Yag Püskürt. Oyugu (Oil Cut-Out)	RK80207600010 -STD RK80207600013 -0.50 RK80207600018 -1.00 2,000 (500) CKP 2,000 (501) P 2,500 (604) CrP	ø25,0 x 60,0	G79101420K_1 A= 79,100 B= 75,300 D= 81,000 F= 5,000 H= 0,000 L= 142,000		+0.25 +0.30
ø76,00 4 Cyl. Diesel 1500 cc 65 PsCommon Rail K9K BP 2002 -..... Clio Symbol 1.5dci Kangoo 1.5 dci Duster 1.5 dci Logan 1.5 dci Logan Epress 1.5 dci Logan MCV 1.5 dci Logan Pickup 1.5 dci Sandero 1.5 dci	18-8050860 STD 18-8050860-20 STD (-0.20 mm) 18-8050860-40 STD (-0.40 mm) 18-8050863 0.50 18-8050863-20 0.50 (-0.20 mm) 18-8050863-40 0.50 (-0.40 mm) 18-8050868 1.00 18-8050868-20 1.00 (-0.20 mm) 18-8050868-40 1.00 (-0.40 mm)	A = 41,700 B = 66,000 C = 14,000 E = -0,430 F = -0,250 CD= 39,700 Segman Taşıyıcı (Ring Carrier)	RK80207600010 -STD RK80207600013 -0.50 RK80207600018 -1.00 2,000 (500) CKP 2,000 (501) P 2,500 (604) CrP	ø26,0 x 60,0	G79101420K_1 A= 79,100 B= 75,300 D= 81,000 F= 5,000 H= 0,000 L= 142,000		+0.25 +0.30

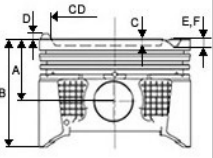





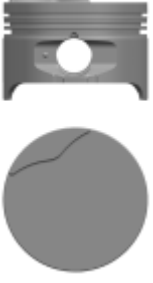

Motor /Engine	Ref. No. Kit 1	Ölçüler /Dimensions	Segman /Rings	Pim	Gömlek /Liner	Kit 2	Info
							
ø76,00 4 Cyl. Diesel 1461 cc 74 Kw (100 Ps) K9K 728 Euro 3 2004 -... Megane II 1,5 DCI Clio	18-8088330 STD 18-8088330-20 STD (-0.20 mm) 18-8088333 0.50 18-8088333-20 0.50 (-0.20 mm) 18-8088338 1.00	A = 41,700 B = 66,000 C = 14,000 E = -0,430 F = -0,250 CD= 39,700 Segman Taşıyıcı (Ring Carrier) Yag Galerisi (Oil Gallery) Yag Püskürt. Oyugu (Oil Cut-Out)	RE49400000 -STD RE49400050 -0.50 RE49400100 -1.00 2,000 (500) CKP 2,000 (501) P 2,500 (604) CrP	ø26,0 x 60,0	G79601420K_1 A= 79,600 B= 75,300 D= 81,500 F= 5,500 H= 0,000 L= 142,000 		+0.25 +0.30
ø76,00 4 Cyl. Diesel 1461cc 78 Kw (106 Ps) Turbo, Intercooler K9K 732 Euro4 K9K 764 Euro4 K9K 780 Euro4 K9K 804 2005 -... Megane II 1.5 dCi Scenic 1.5 dCi Clio Grandtour 1.5 dCi Clio III 1.5 dCi Modus 1.5 dCi Laguna III 1.5 dCi Kangoo 1.5 dCi Kangoo Be Bop 1.5 dCi Kangoo Express 1.5 dCi	18-8088440 STD 18-8088440-20 STD (-0.20 mm) 18-8088443 0.50 18-8088443-20 0.50 (-0.20 mm) 18-8088448 1.00	A = 41,700 B = 66,000 C = 12,800 E = -0,250 F = -0,430 CD= 49,000 Segman Taşıyıcı (Ring Carrier) Yag Galerisi (Oil Gallery) Yag Püskürt. Oyugu (Oil Cut-Out)	RE49400000 -STD RE49400050 -0.50 RE49400100 -1.00 2,000 (500) CKP 2,000 (501) P 2,500 (604) CrP	ø26,0 x 60,0	G79601420K_1 A= 79,600 B= 75,300 D= 81,500 F= 5,500 H= 0,000 L= 142,000 		+0.25 +0.30

Motor /Engine	Ref. No. Kit 1	Ölçüler /Dimensions	Segman /Rings	Pim	Gömlek /Liner	Kit 2	Info
							
ø76,00 4 Cyl. Diesel 1461 cc 81 Kw (110 Ps) K9K Eur 6 2009 -... Juke (F15) 1.5 dCi Qashqai II Suv (J11-J1) Kangoo Megane III Hatchback	18-8092810 STD 18-8092813 0.50 18-8092818 1.00	A = 41,709 B = 66,000 C = 12,860 E = -0,430 CD= 47,000 Segman Taşıyıcı (Ring Carrier) Yag Galerisi (Oil Gallery) Yag Püskürt. Oyugu (Oil Cut-Out)	RE49400000 -STD RE49400050 -0.50 RE49400100 -1.00 2,000 (500) CKP 2,000 (501) P 2,500 (604) CrP	ø26,0 x 60,0	G79601420K_1 A= 79,600 B= 75,300 D= 81,500 F= 5,500 H= 0,000 L= 142,000 		
ø76,00 4 Cyl. Diesel 1461cc 81KW 110HP 15.5:1 K9K 837/846 EURO5 (2010>) OM607 (2013>) 2010>2013> Grand Secnic III 1.5dCi16V Megane Grandtour III 1.5dCi Megane III 1.5dCi Citane 111 CLA 180 CDi GLA 180 CDi A180 CDi B180 CDi	18-8092830 STD 18-8092833 0.50 18-8092838 1.00	A = 41,667 B = 66,000 C = 13,500 E = -0,430 F = -0,250 CD= 47,000 Segman Taşıyıcı (Ring Carrier) Yag Galerisi (Oil Gallery) Yag Püskürt. Oyugu (Oil Cut-Out)	RE49400000 -STD RE49400050 -0.50 RE49400100 -1.00 2,000 (500) CKP 2,000 (501) P 2,500 (604) CrP	ø26,0 x 60,0	G79601420K_1 A= 79,600 B= 75,300 D= 81,500 F= 5,500 H= 0,000 L= 142,000 	 	

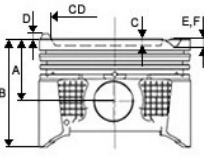







							
Motor /Engine	Ref. No. Kit 1	Ölçüler /Dimensions	Segman /Rings	Pim	Gömlek /Liner	Kit 2	Info
<p>ø77,00</p> <p>4 Cyl. Benzin 1565 cc 69 Kw (94 Ps) 9:1 C2L <u>1985 - 1995</u></p> <p><i>R 11 Rainbow</i> <i>R 21 Optima</i> 1985-1995</p>	<p>18-8010200 STD Gömleklili Kodu 19-8010200 STD</p>	<p>A = 34,000 B = 60,500 C = 1,950 CD= 65,000</p>	<p>RE49350000 -STD</p> <p>1,750 (500) Cr P 2,000 (508) P 4,000 (603) P</p>	<p>ø20,0 x 64,0</p>	<p>G80901340S_1</p> <p>A= 81,000 B= 77,000 D= 90,100 F= 0,000 H= 95,000 L= 134,000</p> 		
<p>ø78,00</p> <p>H4J <i>Megane 3</i></p>	<p>18-8010210 STD 18-8010213 0.50</p>	<p>A = 34,300 B = 52,300 C = 7,680 E = -2,800 F = -6,500</p> <p>Sert Anotlama (Hard Anodising)</p>	<p>RE49500000 -STD RE49500050 -0.50</p> <p>1,200 (500) NitB S IF 1,200 (501) P 2,000 (700) Nit S</p>	<p>ø20,0 x 52,2</p>			

							
Motor /Engine	Ref. No. Kit 1	Ölçüler /Dimensions	Segman /Rings	Pim	Gömlek /Liner	Kit 2	Info
<p>ø78,00</p> <p>4 Cyl. Benzin 1598 cc 84 KW 115 PS H4M <u>2015 -</u> Duster Megane IV</p>	<p>18-8010220 STD 18-8010223 0.50</p>	<p>A = 28,750 B = 48,250 E = -3,750</p> <p>Sert Anotlama (Hard Anodising)</p>	<p>RE49500000 -STD RE49500050 -0.50</p> <p>1,200 (500) NitB S IF 1,200 (501) P 2,000 (700) Nit S</p>	<p>ø19,0 x 53,5</p>			
<p>ø79,50</p> <p>4 Cyl. Benzin 1598 cc 66 Kw (90 Ps) K7M 702/703/720 744 745/746 1.&2.Sil <u>1996 -....</u> 1.&2.Sil. Megane 1.6i RL, RN, RT, RXE Megane Coupe Megane Scenic</p>	<p>17-8010650 STD 17-8010653 0.50 17-8010658 1.00</p>	<p>A = 29,250 B = 56,300 D = 2,550</p> <p>Sac Plaka (Steel Support)</p>	<p>RE49280000 -STD RE49280050 -0.50 RE49280100 -1.00</p> <p>1,500 (500) CrB Fe S IF 1,500 (508) P 2,500 (700) Cr P S</p>	<p>ø19,0 x 62,0</p>			

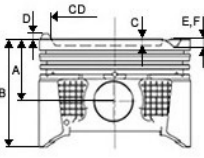







Motor /Engine	Ref. No. Kit 1	Ölçüler /Dimensions	Segman /Rings	Pim	Gömlek /Liner	Kit 2	Info
       							
ø79,50 4 Cyl. Benzin 1598 cc 66 Kw (90 Ps) K7M.702/703/720/744 745/746 3.&4.Sil. 1996 -..... 3.&4. Sil. Megane 16i RL RN-RT-RXE	17-8010660 STD 17-8010663 0.50 17-8010668 1.00	A = 29,250 B = 56,300 D = 2,550 Sac Plaka (Steel Support)	RE49280000 -STD RE49280050 -0.50 RE49280100 -1.00 1,500 (500) CrB Fe S IF 1,500 (508) P 2,500 (700) Cr P S	ø19,0 x 62,0			
							
ø79,50 4 Cyl. Benzin 1400 cc 55 Kw (75 Ps) K7J 1996 -..... Clio Symbol 1.4i 8V Logan 1.4i Logan Express 1.4i Logan MCV 1.4i Logan Pickup 1.4i Sandero 1.4i	18-8010670 STD 18-8010670-20 STD (-0.20 mm) 18-8010673 0.50 18-8010673-20 0.50 (-0.20 mm) 18-8010678 1.00 18-8010678-20 1.00 (-0.20 mm)	A = 35,830 B = 58,000	RE49280000 -STD RE49280050 -0.50 RE49280100 -1.00 1,500 (500) CrB Fe S IF 1,500 (508) P 2,500 (700) Cr P S	ø19,0 x 62,0			
							



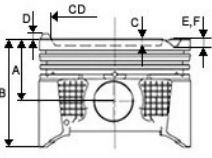



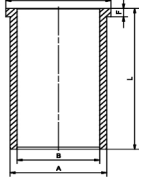

							
Motor /Engine	Ref. No. Kit 1	Ölçüler /Dimensions	Segman /Rings	Pim	Gömlek /Liner	Kit 2	Info
<p>ø79,50</p> <p>4 Cyl. Benzin 1600cc 90 HP K7M 732 <u>2004 -....</u></p> <p><i>Clio Dacia Logan 1 6</i></p>	<p>18-8010680 STD 18-8010683 0.50 18-8010688 1.00</p>	<p>A = 28,310 B = 58,810</p>	<p>RE49280000 -STD RE49280050 -0.50 RE49280100 -1.00</p> <p>1,500 (500) CrB Fe S IF 1,500 (508) P 2,500 (700) Cr P S</p>	<p>ø19,0 x 62,0</p>			
<p>ø79,50</p> <p>4 Cyl. Benzin 1390 cc 72 Kw (98 Ps) 10:1 K4J 730 K4J 710 K4J 780 K4J 770 <u>2004 -....</u></p> <p><i>Megan II 16v Scenic II 16v Clio II 16v Clio III 16v Modüs 16v</i></p>	<p>18-8010690 STD 18-8010693 0.50 18-8010698 1.00</p>	<p>A = 37,200 B = 64,500 E = -1,200 F = -2,100</p>	<p>RE49280000 -STD RE49280050 -0.50 RE49280100 -1.00</p> <p>1,500 (500) CrB Fe S IF 1,500 (508) P 2,500 (700) Cr P S</p>	<p>ø20,0 x 62,0</p>			



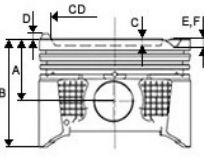







							
Motor /Engine	Ref. No. Kit 1	Ölçüler /Dimensions	Segman /Rings	Pim	Gömlek /Liner	Kit 2	Info
<p>ø79,50</p> <p>4 Cyl. Benzin 1598 cc 110 115 Ps K4M 760 761 <u>2002 -....</u></p> <p>Megane II 1.6 16 V Sedan Mega</p>	<p>18-8010700 STD 18-8010703 0.50</p>	<p>A = 31,700 B = 55,000 C = 1,500 E = -4,000</p> <p>Sert Anotlama (Hard Anodising)</p>	<p>RE49270000 -STD RE49270050 -0.50</p> <p>1,200 (500) CrB Fe S 1,500 (508) P 2,500 (700) Cr P S</p>	<p>ø20,0 x 62,0</p>			
<p>ø79,50</p> <p>4 Cyl. Benzin 1600 cc 95/107/110/116 Ps K4M 708/730/732/750 752/753/754 <u>1998 -....</u></p> <p>Kango 1.6 16V Megane I 1.6 16V Clio 1.6 16V Laguna 1.6 16V</p>	<p>18-8010710 STD 18-8010713 0.50 18-8010718 1.00</p>	<p>A = 31,700 B = 55,000 C = 1,400 E = -2,000 CD= 29,400</p>	<p>RE49280000 -STD RE49280050 -0.50 RE49280100 -1.00</p> <p>1,500 (500) CrB Fe S IF 1,500 (508) P 2,500 (700) Cr P S</p>	<p>ø20,0 x 62,0</p>			

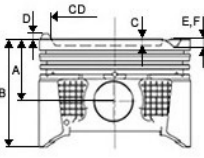







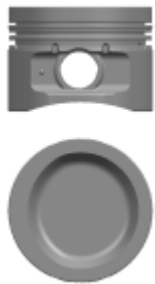

Motor /Engine	Ref. No. Kit 1	Ölçüler /Dimensions	Segman /Rings	Pim	Gömlek /Liner	Kit 2	Info
							
ø80,00 4 Cyl. Diesel 1870 cc 74 Kw (100Ps)18.3: Turbo, Intercooler F9Q. Turbo Intercooler 2000 -... Kangoo 1.9 Tdi Megane 1.9 Tdi Laguna 1.9 Tdi Scenic 1.9 Tdi Traffic 1.9 Tdi Carisma 1.9 GDI Vivaro 1.9 CDTI 8 v	18-8050940 STD 18-8050943 0.50	A = 47,060 B = 77,000 C = 17,800 E = -0,750 CD= 38,000 Segman Taşıyıcı (Ring Carrier) Yag Püskürt. Oyugu (Oil Cut-Out)	RE49380000 -STD RE49380050 -0.50 2,500 (500) CKP 2,000 (501) P 3,000 (604) Cr	ø28,0 x 60,0	G80001550K_1 A= 83,000 B= 79,300 D= 85,000 F= 5,000 H= 0,000 L= 155,000 		+0,60 +0,80
ø80,00 4 Cyl. Diesel 1598cc 96 KW 130PS R9M 402 2015 - Qashgai (2015 -)	18-8092820 STD 18-8092823 0.50	A = 46,000 B = 70,500 C = 12,350 E = -0,300 CD= 46,500 Segman Taşıyıcı (Ring Carrier) Yag Galerisi (Oil Gallery) Yag Püskürt. Oyugu (Oil Cut-Out)	RE49510000 -STD RE49510050 -0.50 2,000 (500) Cpk 1,750 (501) P IFU 2,000 (604) Cr P	ø30,0 x 60,0			

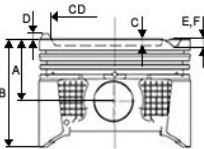









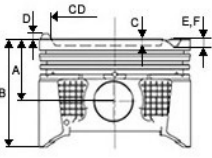

							
Motor /Engine	Ref. No. Kit 1	Ölçüler /Dimensions	Segman /Rings	Pim	Gömlek /Liner	Kit 2	Info
<p>ø80,00</p> <p>4 Cyl. Diesel 1900 cc 81/97Kw 110/132 Ps F9Q 266/759/803/804</p> <p>....-.....</p> <p>MEGANE II 1.9 dCi SCENIC II J 1.9dCi</p>	<p>18-8092950 STD 18-8092953 0.50</p>	<p>A = 47,004 B = 77,000 C = 17,800 E = -0,850 F = -0,850 CD= 40,000</p> <p>Segman Taşıyıcı (Ring Carrier)</p> <p>Yag Galerisi (Oil Gallery)</p> <p>Yag Püskürt. Oyugu (Oil Cut-Out)</p>	<p>RE49380000 -STD RE49380050 -0.50</p> <p>2,500 (500) CKP 2,000 (501) P 3,000 (604) Cr</p>	<p>ø28,0 x 60,0</p>			
<p>ø80,01</p> <p>4 Cyl. Diesel 1870cc 66/81/88 Kw (95/110/120 Ps) F9Q (650/664/670 674/750/756/758 756/812/816/818 808/820/826 1999 - 2009</p> <p>Megane/Laguna II 1.9 dCi Grandtour II 1.9 dCi Scenic/Clio III 1.9 dCi Megane Grandtour 1.9 dCi Grand Scenic II 1.9 dCi Espace IV 1.9 dCi</p>	<p>18-8092930 STD 18-8092933 0.50</p>	<p>A = 47,040 B = 77,000 C = 17,800 E = -0,750 CD= 38,000</p> <p>Segman Taşıyıcı (Ring Carrier)</p> <p>Yag Galerisi (Oil Gallery)</p> <p>Yag Püskürt. Oyugu (Oil Cut-Out)</p>	<p>RE49380000 -STD RE49380050 -0.50</p> <p>2,500 (500) CKP 2,000 (501) P 3,000 (604) Cr</p>	<p>ø28,0 x 60,0</p>			











							
Motor /Engine	Ref. No. Kit 1	Ölçüler /Dimensions	Segman /Rings	Pim	Gömlek /Liner	Kit 2	Info
<p>ø81,00</p> <p>4 Cyl. Benzin 1721 cc 59/60.5/60/90KW (80/82/122 PS) 10:1 F2NA 700/E708 B18E/F/FP/FT <u>1984 - 1989</u></p> <p>Flash R11 GTX/TXE R21 ELECTRONIC R9 GTX/TXE VOLVO 440/460/480</p>	<p>18-8010800 STD 18-8010803 0.50</p>	<p>A = 44,050 B = 70,000 C = 13,900 CD= 60,700</p> <p>Sac Plaka (Steel Support)</p>	<p>RE49110000 -STD RE49110050 -0.50</p> <p>1,750 (500) CrB S IF 2,000 (508) P 3,000 (700) Cr P S</p>	<p>ø21,0 x 65,0</p>			
<p>ø82,70</p> <p>4 Cyl. Benzin 2000 cc F3R 722/723/728/729 <u>1994 -....</u></p> <p>Laguna 1 Mégane Scenic 2.0</p>	<p>18-8010400 STD 18-8010403 0.50</p>	<p>A = 36,170 B = 60,000 C = 9,000 CD= 67,400</p> <p>Sac Plaka (Steel Support)</p>	<p>RE49300000 -STD RE49300050 -0.50</p> <p>1,500 (500) CrB Fe S IF 1,750 (501) P 3,000 (700) Cr P S</p>	<p>ø21,0 x 57,0</p>			

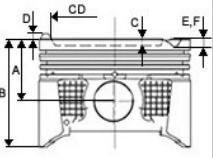











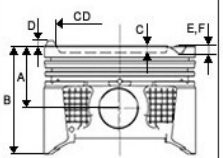





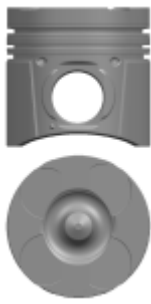
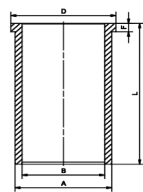

							
Motor /Engine	Ref. No. Kit 1	Ölçüler /Dimensions	Segman /Rings	Pim	Gömlek /Liner	Kit 2	Info
<p>ø82,70</p> <p>4 Cyl. Benzin 1998 cc 140 Ps F4R 770 F 4R 771 <u>2002 -....</u></p> <p><i>Scenic II 2.0 16v Megane II 2.0 16V</i></p>	<p>18-8010410 STD 18-8010413 0.50</p>	<p>A = 30,500 B = 56,900 C = 2,200 E = -1,200 F = -2,000</p>	<p>RE49430000 -STD RE49430050 -0.50</p> <p>1,200 (500) NitB S 1,500 (508) P 2,000 (700) Cr P S</p>	<p>ø21,0 x 61,0</p>			
<p>ø82,70</p> <p>4 Cyl. Benzin 1998 cc 103 Kw (140 Ps) F4R 780 F 4 R 740 F 4 R 712 <u>1999 - 2003</u></p> <p><i>Laguna 2,0 Megane Scenic 2,0 16v Laguna 2,0 16v</i></p>	<p>18-8010420 STD 18-8010423 0.50</p>	<p>A = 30,300 B = 56,800 C = 2,600 E = -1,600 F = -2,000</p>	<p>RE49430000 -STD RE49430050 -0.50</p> <p>1,200 (500) NitB S 1,500 (508) P 2,000 (700) Cr P S</p>	<p>ø21,0 x 61,0</p>			



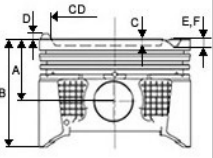





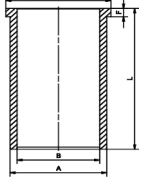
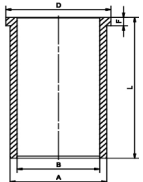



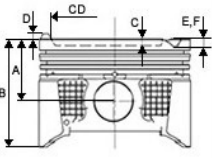
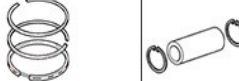

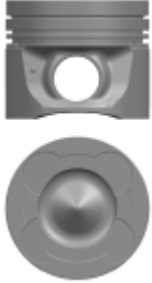
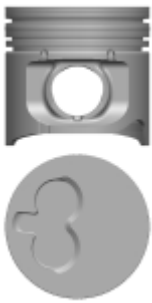
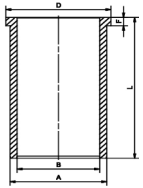

Motor /Engine	Ref. No. Kit 1	Ölçüler /Dimensions	Segman /Rings	Pim	Gömlek /Liner	Kit 2	Info
       							
ø84,00 4 Cyl. Diesel 1995 cc 66 84 KW (90 114 PS) 16:1 127 KW (173 PS) M9R 780 EURO 4 2006> M9R 839 2008> 2006/2008 - Box - Bus dCi 120 Primaster Bus 120 Koleos 2.0 dCi	18-8092440 STD 18-8092443 0.50	A = 48,000 B = 76,000 C = 14,850 E = -0,400 CD= 49,150 Segman Taşıyıcı (Ring Carrier) Yag Galerisi (Oil Gallery)	RE49470000 -STD RE49470050 -0.50 2,500 (503) Cr P 2,000 (501) Cr P IFU 2,000 (604) Nit S	ø32,0 x 65,0			
 							
ø85,00 4 Cyl. Diesel 2298 cc 74/107 KW (101/146 Ps) M9T EURO 4/5 ÇİFT TURBOLU ARAÇLAR M9T 710/702/700 2010 -....	18-8092890 STD 18-8092890-20 STD (-0.20 mm) 18-8092893 0.50 18-8092893-20 0.50 (-0.20 mm)	A = 47,833 B = 74,000 C = 16,200 CD= 50,000 Segman Taşıyıcı (Ring Carrier) Yag Galerisi (Oil Gallery)	RE49540000 -STD RE49540050 -0.50 2,000 (503) CK 1,750 (501) IFU CR 2,000 (604) NIT	ø32,0 x 67,5			
 							



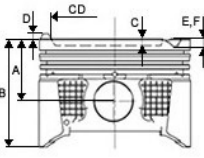





Motor /Engine	Ref. No. Kit 1	Ölçüler /Dimensions	Segman /Rings	Pim	Gömlek /Liner	Kit 2	Info
       							
ø85,01 4 Cyl. Diesel 2298 cc 74/107 Kw (101/146 Ps) M9T EURO 4/5 TEK TURBOLU ARAÇLAR <u>2010 -....</u> Master III 2.3 DCi 100 Master III 2.3 DCi 125	18-8092430 STD 18-8092433 0.50	A = 48,000 B = 76,000 C = 16,200 E = -0,450 CD= 50,000 Segman Taşıyıcı (Ring Carrier) Yag Galerisi (Oil Gallery)	RE49480000 -STD RE49480050 -0.50 2,500 (503) Cr P 2,000 (501) Cr P IFU 2,000 (604) Nit S	ø32,0 x 65,0			
 							
ø86,00 4 Cyl. Diesel 2068 cc 44/46/47/49/ Kw 51/56/65/68 Kw (60/63/64/70 ps /76/88/92 Ps) 852 700 J8S 330/600/704/784/800 J8S 604/620/711/736 J8S 712 <u>1983 -....</u> R 18/20/21/25 2.1D R 18/21 2.1TD Trafic 2.1D/Fuego 2.1TD Master T28 2.1D Jeep CJ-7 2.1D	18-8050430 STD	A = 51,000 B = 92,900 C = 4,200	RE49130000 -STD 2,000 (500) Cr IF 2,000 (501) PIW 4,000 (604) Cr P	ø28,0 x 75,0			



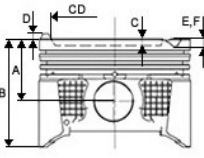





Motor /Engine	Ref. No. Kit 1	Ölçüler /Dimensions	Segman /Rings	Pim	Gömlek /Liner	Kit 2	Info
							
ø87,00 4 Cyl. Diesel 2188cc 66 Kw(90 Ps) 18:1 Turbo , Intercooler C.Rail G9T 722/720/750 2000 -..... (Turbo-Intercooler/C.Rail) Movano 2.2 DTI 16v Espace IV 2.2 TDCI Laguna 2.2 TDCI Master 2.2 TDCI Velsatis 2.2 TDCI	18-8050330 STD 18-8050333 0.50	A = 54,530 B = 84,200 C = 17,500 E = -1,600 F = -2,000 CD= 40,400 Segman Taşıyıcı (Ring Carrier) Yag Püskürt. Oyugu (Oil Cut-Out)	RE49440000 -STD RE49440050 -0.50 3,000 (503) CKP 1,750 (501) P 2,500 (604) P	ø31,0 x 65,0			+0.6 +0.40
	ø89,00 4 Cyl. Diesel 2463 cc 84 Kw (115 Ps) 17.75:1 Common Rail G9U Euro 3 720/724/730/750/754 2001-2006 Master II 2.5 Dci OPEL/Movano Box Movano Platform Vivaro Box Vivaro Platform	18-3050290 STD 18-3050290-20 STD (-0.20 mm) 18-3050290-40 STD (-0.40 mm) 18-3050293 0.50 18-3050293-20 0.50 (-0.20 mm) 18-3050293-40 0.50 (-0.40 mm)	A = 53,030 B = 83,090 C = 17,850 E = -1,600 F = -2,000 CD= 43,200 Segman Taşıyıcı (Ring Carrier) Yag Püskürt. Oyugu (Oil Cut-Out)	RE49450000 -STD RE49450050 -0.50 2,500 (500) Cr P IF 1,750 (501) P IFU 2,500 (604) Cr P	ø31,0 x 65,0	G92001680K_1 A= 92,000 B= 88,300 D= 93,500 F= 5,000 H= 0,000 L= 168,000 	+0,35 +0,60
							



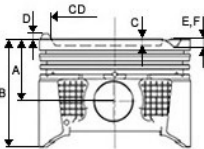



Motor /Engine	Ref. No. Kit 1	Ölçüler /Dimensions	Segman /Rings	Pim	Gömlek /Liner	Kit 2	Info
       							
ø89,00 4 Cyl. Diesel 2463 cc 84 Kw (115 Ps) 17.75 G9U Euro 4 632/650 <u>2001-2006</u> Master II 2,5 Dci OPEL/Movano Box Movano Platform Vivaro Box Vivaro Platform	18-3050300 STD 18-3050303 0.50	A = 53,075 B = 83,090 C = 16,130 E = -1,600 F = -2,000 CD= 48,000 Segman Taşıyıcı (Ring Carrier)	RE49490000 -STD RE49490050 -0.50 3,000 (503) Cr P 1,750 (508) P 2,500 (604) Nit S	ø31,0 x 65,0	G92001680K_1 A= 92,000 B= 88,300 D= 93,500 F= 5,000 H= 0,000 L= 168,000 		
ø89,00 4 Diesel, 2464 cm ³ 74/107 kW (101/146 PS) 18:1 18,1:1,16 Ventile G9U 630 G9U 632 G9U 650 <u>10/2003</u> INTERSTAR DCI 100/120/150 PRIMASTAR DCI 150 MOVANO-A 2.5 CDTI VIVARO 2.5 CDTI/DTI TRAFIC II 2.5 DCI MASTER II 2.5 DCI	18-3092350 STD 18-3092353 0.50	A = 53,075 B = 83,090 C = 16,300 E = -2,000 F = -1,700 CD= 48,000 Segman Taşıyıcı (Ring Carrier) Yag Galerisi (Oil Gallery) Yag Püskürt. Oyugu (Oil Cut-Out)	RE49490000 -STD RE49490050 -0.50 3,000 (503) Cr P 1,750 (508) P 2,500 (604) Nit S	ø31,0 x 68,0	G92001680K_1 A= 92,000 B= 88,300 D= 93,500 F= 5,000 H= 0,000 L= 168,000 		





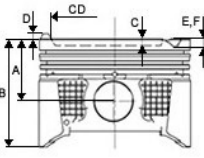
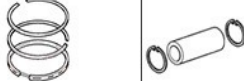

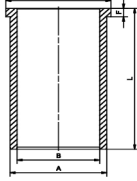

Motor /Engine	Ref. No. Kit 1	Ölçüler /Dimensions	Segman /Rings	Pim	Gömlek /Liner	Kit 2	Info	
								
ø89,00 4 Cyl. Diesel 2488 cc 106 Kw 76/81/ KW 103/110/144 Ps YD25DDTI (D40) Renault Truck DXi 2.5 2008 -.... Navara 2.5 dci	18-8092340 STD 18-8092343 0.50	A = 48,850 B = 73,800 C = 17,400 E = -1,200 F = -0,750 CD= 47,400 Segman Taşıyıcı (Ring Carrier) Yag Galerisi (Oil Gallery)	RJ23265A00 -STD RJ23265C00 -0.50 2,000 () GN SM 2,000 () 3,000 () DN	ø28,0 x 70,9				
								
ø93,00 4 Cyl. Diesel 2499 cc 62 Kw (85 Ps) Atmospheric Göz Arası Konik SOFIM 2/5 Düz 2001 -.... Ducato 2.5 D Movano 2.5 D Master 2.5 D	18-3051880 STD 18-3051880-20 STD (-0.20 mm) 18-3051882 0.40 18-3051882-20 0.40 (-0.20 mm)	A = 54,000 B = 89,000 C = 2,200 Segman Taşıyıcı (Ring Carrier) Sert Anotlama (Hard Anodising) Yag Püskürt. Oyugu (Oil Cut-Out)	RE22340000 -STD RE22340040 -0.40 RE22340060 -0.60 3,000 (504) Cr P 2,000 (501) P 3,000 (604) Cr P	ø32,0 x 68,0	G96001670K_1 A= 96,000 B= 93,000 D= 98,900 F= 5,000 H= 0,000 L= 167,300			+0,40 +0,50 1.20 mm Conta +0,51 +0,60 1.30 mm Conta +0,61 +0,70 1.40 mm Conta



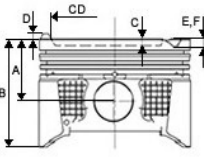





							
Motor /Engine	Ref. No. Kit 1	Ölçüler /Dimensions	Segman /Rings	Pim	Gömlek /Liner	Kit 2	Info
<p>ø108,00</p> <p>4/6 Cyl.Diesel 147/118/265 140 158/162/177 206/235 KW 160/200*360 190/215/220 360/240/280 320 PS TCD 2013 L06 4V Euro 3 Euro4 DXi5 (190/215/220/360) DX7(240/280/320) 2006 -.</p> <p>AGROTRON X TCD 2013 L06 MIDLUM II-SHEPRA D7F240 D7F260 D7F215 D7F290 D7E240 D7F300 D7E280 D7F340 D7E320</p>	<p>17-8692100 STD</p>	<p>A = 70,900 B = 107,800 C = 19,600 CD= 64,610</p>		<p>ø45,0 x 86,0</p>			



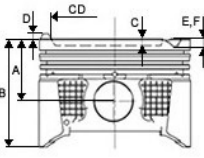





							
Motor /Engine	Ref. No. Kit 1	Ölçüler /Dimensions	Segman /Rings	Pim	Gömlek /Liner	Kit 2	Info
<p>ø73,00</p> <p>4 Cyl. Benzin 1295 cc 55KW 97PS 9:1 2E/C/U/L <u>1987 - 1995</u></p> <p><i>Corolla 1300 DLX</i> <i>Corolla 1300 GL</i> <i>Corolla 1300 XL</i></p>	<p>18-4510090 STD</p> <p>18-4510093 0.50</p>	<p>A = 53,100 B = 89,600 C = 20,100 CD= 44,000</p>	<p>RJ28012A00 -STD RJ28012C00 -0.50</p> <p>1,500 () GN SV 1,500 () 3,000 ()</p>	<p>ø18,0 x 59,0</p>			
<p>ø73,00</p> <p>4 Cyl. Diesel 1364 cc 90 Ps 1ND TV <u>2005 -....</u></p> <p><i>Corolla 1.4D-4D</i> <i>Auris 1.4D-4D</i> <i>Yaris 1.4D-4D</i></p>	<p>18-4592100 STD</p> <p><i>18-4592100-20 STD</i> <i>(-0.20 mm)</i></p> <p>18-4592103 0.50</p> <p><i>18-4592103-20 0.50</i> <i>(-0.20 mm)</i></p>	<p>A = 41,940 B = 64,350 C = 14,700 E = -0,900 CD= 36,500</p> <p>Segman Taşıyıcı (Ring Carrier)</p> <p>Sert Anotlama (Hard Anodising)</p> <p>Yag Galerisi (Oil Gallery)</p>	<p>RJ39642A00 -STD RJ39642C00 -0.50</p> <p>1,500 (500) NitB St 1,500 (501) CrB St 3,000 (604) Nit St</p>	<p>ø27,0 x 59,3</p>			



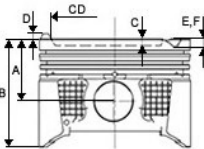
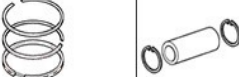





							
Motor /Engine	Ref. No. Kit 1	Ölçüler /Dimensions	Segman /Rings	Pim	Gömlek /Liner	Kit 2	Info
<p>ø73,00</p> <p>4 Cyl. Diesel 1364 cc 50 kW 68 Ps 18.5 1ND TV 1.4 D 4D <u>2012 -....</u> 2012 ... Auris Corolla Verso Yaris</p>	<p>18-4592200 STD 18-4592203 0.50</p>	<p>A = 41,990 B = 64,400 C = 15,100 E = -0,900 CD= 37,500</p> <p>Segman Taşıyıcı (Ring Carrier)</p> <p>Sert Anotlama (Hard Anodising)</p> <p>Yag Galerisi (Oil Gallery)</p>		<p>ø27,0 x 59,3</p>			
<p>ø79,00</p> <p>4 Cyl. Benzin 1598 cc 110PS 3ZZ/FE <u>2001 -</u> Corolla 1.6 VVTi</p>	<p>18-4510300 STD 18-4510303 0.50</p>	<p>A = 32,200 B = 52,200 C = 3,800 E = -5,600</p> <p>Sert Anotlama (Hard Anodising)</p>	<p>RJ28785A00 -STD RJ28785C00 -0.50</p> <p>1,200 () SV 1,200 () 3,000 ()</p>	<p>ø20,0 x 50,0</p>			



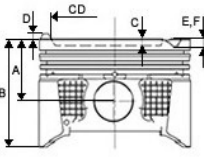





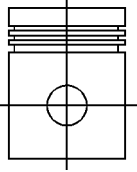

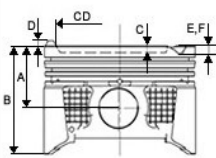

							
Motor /Engine	Ref. No. Kit 1	Ölçüler /Dimensions	Segman /Rings	Pim	Gömlek /Liner	Kit 2	Info
<p>ø79,00</p> <p>4 Cyl. Benzin 1398 cc 97PS 4ZZ/FE <u>2001 -</u> Corolla 1.4 Terra VVT-i</p>	<p>18-4510310 STD 18-4510313 0.50</p>	<p>A = 32,200 B = 51,700 C = 2,200 E = -5,400</p> <p>Sert Anotlama (Hard Anodising)</p>	<p>RJ28785A00 -STD RJ28785C00 -0.50</p> <p>1,200 () SV 1,200 () 3,000 ()</p>	<p>ø20,0 x 50,0</p>	<p>G79001400K_1</p> <p>A= 82,000 B= 78,300 D= 83,000 F= 5,000 H= 0,000 L= 140,000</p> 		
<p>ø80,50</p> <p>4 Cyl. Benzin 1598 cc 91/97PS 1ZR/FE&1ZR/FAE 1.6 16V <u>2007 -</u> Aurs Avensis Corolla Verso</p>	<p>18-4510320 STD 18-4510323 0.50</p>	<p>A = 35,900 B = 55,000 C = 3,700 E = -5,800 F = -5,100</p> <p>Sert Anotlama (Hard Anodising)</p>		<p>ø20,0 x 50,0</p>			









							
Motor /Engine	Ref. No. Kit 1	Ölçüler /Dimensions	Segman /Rings	Pim	Gömlek /Liner	Kit 2	Info
<p>ø81,00</p> <p>4 Cyl. Benzin 1600 cc 4AF Karbüratörlü <u>1988 - 1992</u> Corolla 1.6 Lt Karbüratörlü</p>	<p>18-4510330 STD 18-4510333 0.50</p>	<p>A = 30,500 B = 61,000 C = 2,800</p> <p>Sert Anotlama (Hard Anodising)</p>	<p>RJ28265A00 -STD RJ28265C00 -0.50</p> <p>1,500 () CrI SV 1,500 () 3,000 () CrI</p>	<p>ø18,0 x 61,0</p>			
<p>ø81,00</p> <p>4 Cyl. Benzin 1600 cc 4AFE Injection <u>1987 -</u> Corolla 1.6 Lt Enjeksiyonlu</p>	<p>18-4510340 STD 18-4510343 0.50</p>	<p>A = 30,500 B = 55,500 C = 2,600 E = -2,800 F = -2,350 CD= 67,800</p> <p>Sert Anotlama (Hard Anodising)</p>	<p>RJ28251A00 -STD RJ28251C00 -0.50</p> <p>1,200 () St N 1,500 () CI 3,000 () St N700</p>	<p>ø20,0 x 56,0</p>			



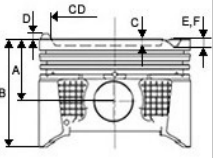





							
Motor /Engine	Ref. No. Kit 1	Ölçüler /Dimensions	Segman /Rings	Pim	Gömlek /Liner	Kit 2	Info
<p>ø92,00</p> <p>4 Cyl. Diesel 2445 cc 79PS 2L/11 <u>1978 - 1995</u> Hiace</p>	<p>18-4551350 STD 18-4551353 0.50</p>	<p>A = 44,350 B = 80,350 C = 1,600</p> <p>Sac Plaka (Steel Support)</p> <p>Yag Püskürt. Oyugu (Oil Cut-Out)</p>	<p>RJ28740A00 -STD RJ28740C00 -0.50</p> <p>2,000 () SX 2,000 () 4,000 ()</p>	<p>ø27,0 x 70,0</p>			



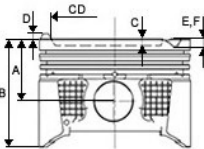



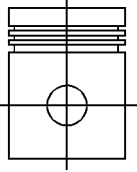
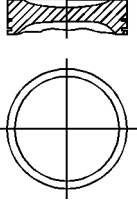

							
Motor /Engine	Ref. No. Kit 1	Ölçüler /Dimensions	Segman /Rings	Pim	Gömlek /Liner	Kit 2	Info
<p>ø67,10</p> <p>4 Cyl. Benzin, 999 cm³ 37 kW (50 hp), 10,5/7:1 8 Ventile AER ALL <u>1996 - 2005</u></p> <p><i>Polo 1.0 Lupo 1.0 Arosa 1.0 Cordoba I 1.0 I Ibiza II 1.0 I</i></p> 	<p>18-7010340 STD 18-7010343 0.50</p>	<p>A = 31,270 B = 56,270 C = 5,700 CD= 51,000</p>	<p>RE56080000 -STD RE56080050 -0.50</p> <p>1,000 (500) Cr B S IF 1,200 (508) P 2,000 (700) Cr P S</p>	<p>ø17,0 x 45,0</p>			
<p>ø69,50</p> <p>4 Cyl. Benzin, 895 cm³ 29,5 kW (40 hp), 8:1 FA FJ GG HB <u>1974 -....</u></p> <p><i>Golf Polo Jetta Audi 50</i></p> 	<p>18-7010010 STD 18-7010013 0.50</p>	<p>A = 40,200 B = 67,000 C = 4,000</p>	<p>RE53050000 -STD RE53050050 -0.50</p> <p>1,500 (500) Cr S 1,500 (501) P 3,000 (700) Cr S P</p>	<p>ø20,0 x 54,0</p>			



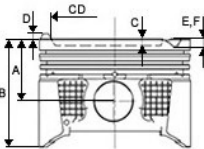



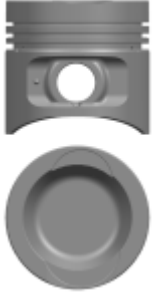
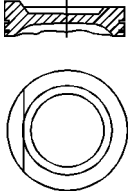

							
Motor /Engine	Ref. No. Kit 1	Ölçüler /Dimensions	Segman /Rings	Pim	Gömlek /Liner	Kit 2	Info
<p>ø69,50</p> <p>4 Cyl. Benzin, 895 cm³ 29,5 kW (40 hp), 8:1 HB HD <u>1974 -....</u> <i>Polo 1.1</i> <i>Derby 1.1</i></p> 	<p>18-7010040 STD 18-7010043 0.50</p>	<p>A = 40,350 B = 64,350</p>	<p>RE56000000 -STD RE56000050 -0.50 RE56000100 -1.00</p> <p>1,750 (500) Cr P IF 2,000 (508) P 4,000 (603) P</p>	<p>ø20,0 x 58,0</p>			
<p>ø71,00</p> <p>4 Cyl. Benzin 1197 63/66/77 Kw 8690//105 Ps CBZA CBZB CBZC <u>2010 -</u> <i>Golf</i> <i>Jetta</i> <i>Polo</i></p>	<p>18-7010020 STD 18-7010023 0.50</p>	<p>A = 28,900 B = 45,000 C = 4,400</p>	<p>RE49730000 -STD RE49730025 -0.25 RE49730050 -0.50</p> <p>1,000 (500) NitB S 1,200 (501) Cr P 2,000 (700) Nit S</p>	<p>ø19,0 x 42,0</p>			

Motor /Engine	Ref. No. Kit 1	Ölçüler /Dimensions	Segman /Rings	Pim	Gömlek /Liner	Kit 2	Info
       							
ø71,00 4 Cyl. Benzin 1197 cc 62/81KW 84/110 PS 1.2 TSI CYVC CJZB CYVB CJZA CJZD) <u>2013 -....</u> Caddy IV Golf VII Polo	18-7010030 STD 18-7010033 0.50	A = 28,000 B = 44,500 D = 0,700 Sert Anotlama (Hard Anodising)	RE56500000 -STD RE56500025 -0.25 RE56500050 -0.50 RE56500100 -1.00 1,200 (500) Nit S 1,200 (501) Cr P 2,000 (700) Nit S	ø17,0 x 49,0			
 							
ø71,00 4 Cyl. Benzin 1197 cc Fit EA211 1.2 TSI L4 Turbocharged CJZA CYVB CYVD CYVC CJZ CYV <u>2013 - 2021</u> A3 (8V) BEETLE CADDY-GOLF(MK7) JETTA POLO (6R) TOURAN FABIA OCTAVIA RAPID YETI IBIZA LEON TOLEDO	18-7010710 STD 18-7010713 0.50	A = 27,800 B = 44,400 D = 0,500 E = -2,900 F = -4,000 Sert Anotlama (Hard Anodising)		ø17,0 x 47,5			
 							

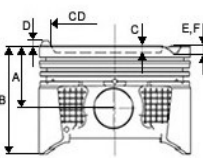







Motor /Engine	Ref. No. Kit 1	Ölçüler /Dimensions	Segman /Rings	Pim	Gömlek /Liner	Kit 2	Info
       							
ø74,50 4 Cyl. Benzin 1395 cc 85/125kW 115/170 PS 10.5:1 CZCA CXSB CPVB CZDD 2013 - Passat Tiguan Scirocco-Golf	18-7010090 STD 18-7010093 0.50	A = 31,000 B = 48,000 C = 1,250 E = -2,900 F = -4,400 CD= 49,000 Sert Anotlama (Hard Anodising)	RE56480000 -STD RE56480050 -0.50 1,200 () 1,200 () 2,000 ()	ø19,0 x 47,0			
ø74,50 4 Cyl. Benzin GÜÇLENDİRİLMİŞ CZD CZD A/B CZC CZC A/B/C CXS CPV CPV A/B/C 1.4 TSI TFSI (Yeni Triger Kayışı EA211)	18-7010700 STD 18-7010703 0.50	A = 30,800 B = 47,800 C = 1,850 E = -2,750 F = -4,500 CD= 60,600 Segman Taşıyıcı (Ring Carrier)		ø19,0 x 50,0			

							
Motor /Engine	Ref. No. Kit 1	Ölçüler /Dimensions	Segman /Rings	Pim	Gömlek /Liner	Kit 2	Info
<p>ø75,00</p> <p>4 Cyl. Benzin, 1272 cm³ 40 kW (55 hp), 8,2:1 FY FZ GF GS GT HH HJ <u>1979 -....</u></p> <p><i>Golf Jetta Passat Santana</i></p> 	<p>18-7010050 STD 18-7010053 0.50</p>	<p>A = 38,300 B = 66,300</p>	<p>RE56020000 -STD RE56020050 -0.50 RE56020100 -1.00</p> <p>1,750 (500) CrB S IF 2,000 (508) P 4,000 (700) Cr P S</p>	<p>ø20,0 x 58,0</p>			
<p>ø75,00</p> <p>4 Cyl. Benzin, 1296 cm³ 44 kW (60 hp), 8,5:1 ZA ZF <u>1972 - 1983</u></p> <p><i>Audi 80 1.3 VW Passat 1.3</i></p> 	<p>18-7010060 STD 18-7010063 0.50</p>	<p>A = 45,500 B = 77,500 C = 4,500 CD= 57,800</p>	<p>RE56040000 -STD RE56040050 -0.50 RE56040100 -1.00</p> <p>2,000 (500) CrB Fe S IF 2,500 (508) P 4,000 (700) Cr P S</p>	<p>ø22,0 x 63,0</p>			

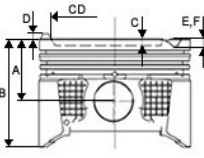







							
Motor /Engine	Ref. No. Kit 1	Ölçüler /Dimensions	Segman /Rings	Pim	Gömlek /Liner	Kit 2	Info
<p>ø75,00</p> <p>4 Cyl. Benzin, 1272 cm³ 40 kW (54 hp), 9,5:1 AAV HK HW MH NU NZ 2G <u>1985 - 1992</u></p> <p><i>Polo Golf Jetta Derby Ibiza II 1.3 I</i></p> 	<p>18-7010260 STD 18-7010263 0.50</p>	<p>A = 42,870 B = 64,870 C = 16,600 E = -1,500 F = -1,650 CD= 56,600</p>	<p>RE56030000 -STD RE56030050 -0.50 RE56030100 -1.00</p> <p>1,750 (500) CrB Fe S IF 2,000 (508) P 3,000 (700) Cr P S</p>	<p>ø20,0 x 54,0</p>			
<p>ø75,00</p> <p>4 Cyl. Benzin 1043 cc 33 Kw (45 Ps) 9.8: AAU <u>1990 - 1994</u></p> <p><i>Golf Polo Vento (1990-1994)</i></p> 	<p>18-7010360 STD</p>	<p>A = 47,370 B = 73,500 C = 6,800 CD= 1,000</p> <p>Sac Plaka (Steel Support)</p>	<p>RE56070000 -STD</p> <p>1,500 (500) CrB Fe S IF 1,500 (501) P 2,500 (700) Cr P S</p>	<p>ø20,0 x 50,0</p>			



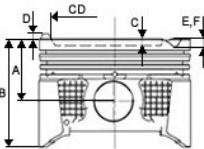





							
Motor /Engine	Ref. No. Kit 1	Ölçüler /Dimensions	Segman /Rings	Pim	Gömlek /Liner	Kit 2	Info
<p>ø75,00</p> <p>4 Cyl. Benzin 1391 cc 44 kW 60 PS 9,2:1 ABD <u>1991 - 1995</u> GIII 1.4 60 CV</p>	<p>18-7010550 STD 18-7010553 0.50</p>	<p>A = 34,520 B = 56,520 C = 15,220 E = -1,650</p>	<p>RE56070000 -STD 1,500 (500) CrB Fe S IF 1,500 (501) P 2,500 (700) Cr P S</p>	<p>ø17,0 x 48,0</p>			
<p>ø76,50</p> <p>4 Cyl. Benzin 1390cc 103 Kw (140/170 Hp) GÜÇLENDİRİLMİŞ BMW BLG CAVD <u>2006 -....</u> GOLF 1.4 TSI JETTA 1.4 TSI Jetta 1.4TSI16V Touran 1.4FSI16V Touran 1.4 TSI16V Golf Plus 1.4TSI16V Golf V 1.4FSI+TSI16V Tiguan 1.4TSI16V Scirocco 1.4TSI16V Beetle 1.4TSI</p>	<p>18-7010280 STD 18-7010280-30 STD 18-7010283 0.50 18-7010283-30 0.50</p>	<p>A = 29,000 B = 48,000 C = 4,550 D = 1,850 E = -1,000 F = -3,800</p> <p>Segman Taşıyıcı (Ring Carrier)</p> <p>Sert Anotlama (Hard Anodising)</p>	<p>RE56200000 -STD RE56200050 -0.50 1,200 (500) NitBS 1,500 (501) P 2,000 (700) NitS</p>	<p>ø19,0 x 54,0</p>			



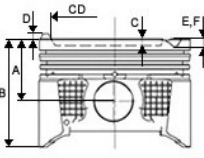





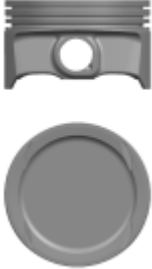
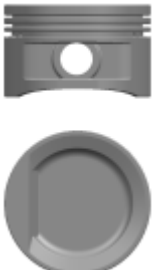



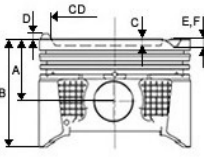







							
Motor /Engine	Ref. No. Kit 1	Ölçüler /Dimensions	Segman /Rings	Pim	Gömlek /Liner	Kit 2	Info
<p>ø76,50</p> <p>4 Cyl. Benzin, 1598 cm³ 55 kW (75 hp), 9,3:1 ABU <u>1992 - 1999</u></p> <p><i>Golf III Polo Vento</i></p>	<p>18-7010510 STD 18-7010513 0.50</p>	<p>A = 32,000 B = 54,000 C = 8,700 CD= 64,000</p>	<p>RE56090000 -STD RE56090050 -0.50</p> <p>1,500 (500) CrB Fe S IF 1,500 (508) P 2,500 (700) Cr P S</p>	<p>ø17,0 x 52,0</p>			
<p>ø76,50</p> <p>4 Cyl. Benzin 1390 cc 40 44 Kw (54 60 Ps) AEX <u>1995 - 1997</u></p> <p><i>Golf Polo Vento/1389 cc</i></p>	<p>18-7010530 STD 18-7010533 0.50</p>	<p>A = 28,350 B = 50,350 C = 5,900</p>	<p>RE56310000 -STD RE56310050 -0.50</p> <p>1,200 (500) NitB S IF 1,500 (508) P 2,500 (700) Cr P S</p>	<p>ø17,0 x 52,0</p>			

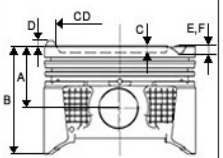





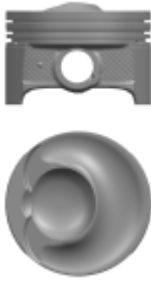
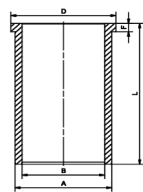





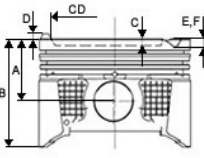





							
Motor /Engine	Ref. No. Kit 1	Ölçüler /Dimensions	Segman /Rings	Pim	Gömlek /Liner	Kit 2	Info
<p>ø76,50</p> <p>4 Cyl. Benzin 1598 cc 55 Kw (75 Ps) 9.8:1 AEA AEE AHS ALM <u>1994 - 1999</u></p> <p>Golf Polo Vento Felicia Octavia</p>	<p>18-7010540 STD 18-7010543 0.50</p>	<p>A = 30,850 B = 60,400 C = 8,000</p>	<p>RE56310000 -STD RE56310050 -0.50</p> <p>1,200 (500) NitB S IF 1,500 (508) P 2,500 (700) Cr P S</p>	<p>ø17,0 x 52,0</p>			
<p>ø76,50</p> <p>3 Cyl. Benzin 1198 cc 47 kW 64 PS 10,5:1 12 Ventile AZQ BME <u>2001 -</u></p> <p>POLO (9N ,9A) IBIZA III (6L1) CORDOBA (6L2) FABIA I ROOMSTER (5J7)</p>	<p>17-7010560 STD 17-7010563 0.50</p>	<p>A = 29,400 B = 50,400 C = 4,000 E = -2,600 F = -1,700 CD= 62,300</p>	<p>RE56310000 -STD RE56310050 -0.50</p> <p>1,200 (500) NitB S IF 1,500 (508) P 2,500 (700) Cr P S</p>	<p>ø17,0 x 46,0</p>			



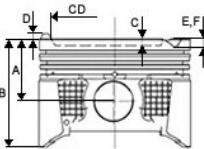





							
Motor /Engine	Ref. No. Kit 1	Ölçüler /Dimensions	Segman /Rings	Pim	Gömlek /Liner	Kit 2	Info
<p>ø76,50</p> <p>4 Cyl. Benzin 1390 cc 55/59/63/75/80/85 kW 75/80/85/86 PS 10,5:1 BUD CDDA CGGA CGGB CLPA Euro 5*BKY*BXM BKR 2000 -</p> <p>1.4 Caddy III Golf V Golf VI Golf Plus Polo Polo IV Sedan Polo V Altea/XL Cordoba Ibiza III/IV Leon Toledo III Fabia I/Praktik/II/Combi Octavia II/Combi Roomster/Praktik</p>	<p>18-7010570 STD 18-7010573 0.50</p> 	<p>A = 28,920 B = 46,920 C = 2,300 E = -1,400 F = -1,600 CD= 62,000</p> <p>Sert Anotlama (Hard Anodising)</p>	<p>RE56450000 -STD RE56450050 -0.50</p> <p>1,200 (500) NitB S 1,200 (501) P 2,000 (700) Nit S</p>	<p>ø17,0 x 46,0</p>			
<p>ø76,50</p> <p>4 Cyl. Benzin, 1390 cm³ 44 kW (60 hp) AKK ANW AUD 1996 -</p> <p>Golf Polo Vento</p>	<p>18-7010610 STD 18-7010613 0.50</p> 	<p>A = 28,500 B = 48,500 C = 5,360</p>	<p>RE56310000 -STD RE56310050 -0.50</p> <p>1,200 (500) NitB S IF 1,500 (508) P 2,500 (700) Cr P S</p>	<p>ø17,0 x 52,0</p>			



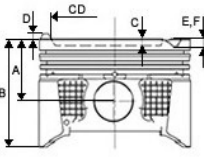



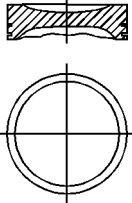
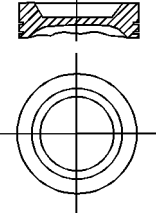

							
Motor /Engine	Ref. No. Kit 1	Ölçüler /Dimensions	Segman /Rings	Pim	Gömlek /Liner	Kit 2	Info
<p>ø76,50</p> <p>4 Cyl. Benzin 1390cc 90 92 KW(122 125 BG) CAX CAXA CMSA <u>2007 -....</u></p> <p>VW EOS 1.4FSI16V VW Golf Plus 1.4FSI16V Golf V 1.4FSI16V Golf V 1.4TFSI16V Golf V 1.4TFSI16V Jetta 1.4FSI16V Passat 1.4FSI16V Scirocco 1.4TFSI16V</p>	<p>18-7010630 STD 18-7010633 0.50</p>	<p>A = 29,200 B = 48,200 C = 4,500 E = -3,600 F = -0,700</p> <p>Sert Anotlama (Hard Anodising)</p>	<p>RE56450000 -STD RE56450050 -0.50</p> <p>1,200 (500) NitB S 1,200 (501) P 2,000 (700) Nit S</p>	<p>ø19,0 x 52,0</p>			
<p>ø76,50</p> <p>4 Cyl. Benzin 1390cc 103 KW (170 Ps) BMY BLG CAVD <u>2006 -....</u></p> <p>Jetta 1.4TSI16V Touran 1.4FSI16V Touran 1.4 TSI16V Golf Plus 1.4TSI16V Golf V 1.4FSI+TSI16V Tiguan 1.4TSI16V Scirocco 1.4TSI16V Beetle 1.4TSI</p>	<p>18-7010640 STD 18-7010643 0.50</p>	<p>A = 29,000 B = 48,200 C = 5,900 D = 1,850 E = -1,100 F = -3,900</p> <p>Sert Anotlama (Hard Anodising)</p>	<p>RE56200000 -STD RE56200050 -0.50</p> <p>1,200 (500) NitBS 1,500 (501) P 2,000 (700) NitS</p>	<p>ø19,0 x 52,0</p>			



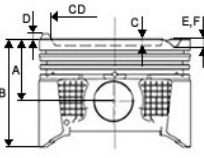



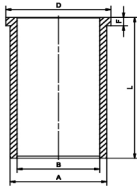

Motor /Engine	Ref. No. Kit 1	Ölçüler /Dimensions	Segman /Rings	Pim	Gömlek /Liner	Kit 2	Info
							
ø76,50 4 Cyl. Benzin 1600 cc 115 Ps BAG BLF BLP 2003 -..... Golf V Passat Jetta	18-7010660 STD 18-7010663 0.50	A = 29,300 B = 49,300 C = 6,000 D = 4,500 E = -2,800 Sert Anotlama (Hard Anodising)	RE56450000 -STD RE56450050 -0.50 1,200 (500) NitB S 1,200 (501) P 2,000 (700) Nit S	ø17,0 x 47,0			
							
ø76,50 4 Cyl. Diesel 1588 cc 2383 cc 37/40/44/51 /55/57/60,5 Kw (50/54/60/69/75/78/82 Ps) D24 ADK CR JK JP CY JR JX MF ATC 1S CP DW 751 1980 - 1992 Volvo 240D/244D/245D/740D Golf Polo Bora Audi 80 1.6D/TD Audi 90 1.6TD Audi 100 2.0D/TD Audi 100 2.4TD SKODA	18-7050760 STD 18-7050763 0.50	A = 41,700 B = 71,700 C = 1,600 Segman Taşıyıcı (Ring Carrier) Sac Plaka (Steel Support)	RE56110000 -STD RE56110050 -0.50 RE56110100 -1.00 1,750 (500) CrB Fe S 2,000 (501) Cr IFU 3,000 (604) Cr	ø24,0 x 64,0	G79501420K_1 A= 79,500 B= 75,810 D= 82,500 F= 4,700 H= 0,000 L= 142,000		1. çentik 1.40 mm conta + 0,67 + 0,80 2. çentik 1.50 mm conta + 0,81 + 0,90 3. çentik 1.60 mm conta + 0,91 + 1,02
							



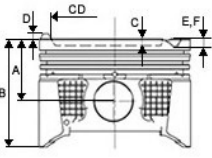





							
Motor /Engine	Ref. No. Kit 1	Ölçüler /Dimensions	Segman /Rings	Pim	Gömlek /Liner	Kit 2	Info
<p>ø76,51</p> <p>4 Cyl. Benzin 1598 cc 77 Kw (105 Ps) AUS AZD BCB ATN <u>2001 - 2006</u></p> <p>Bora Golf (2001 - 2006)</p>	<p>18-7010520 STD 18-7010523 0.50</p>	<p>A = 29,270 B = 50,270 C = 2,800 E = -1,400 F = -2,350</p>	<p>RE56310000 -STD RE56310050 -0.50</p> <p>1,200 (500) NiB S IF 1,500 (508) P 2,500 (700) Cr P S</p>	<p>ø17,0 x 54,0</p>			
<p>ø76,51</p> <p>4 Cyl. Diesel 1588 cc 59 Kw (80 Ps) 23:1 RA SBDE <u>1989 - 1993</u></p> <p>Golf Jetta Passat 1989 - 1993</p>	<p>18-7081140 STD 18-7081143 0.50 18-7081148 1.00</p>	<p>A = 41,700 B = 71,700 C = 1,600</p> <p>Segman Taşıyıcı (Ring Carrier)</p> <p>Sert Anotlama (Hard Anodising)</p> <p>Sac Plaka (Steel Support)</p> <p>Yağ Püskürt. Oyugu (Oil Cut-Out)</p>	<p>RE56100000 -STD RE56100050 -0.50 RE56100100 -1.00</p> <p>1,750 (500) CrB Fe S 2,000 (501) P IFU 3,000 (604) Cr</p>	<p>ø24,0 x 64,0</p>			<p>1.çentik 1.53 mm conta +0,66 +0,80</p> <p>2.çentik 1.57 mm conta +0,81 +0,90</p> <p>3.çentik 1.61 mm conta +0,91 +1,02</p>



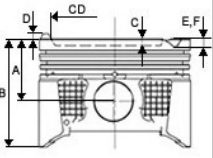



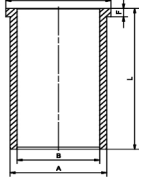

							
Motor /Engine	Ref. No. Kit 1	Ölçüler /Dimensions	Segman /Rings	Pim	Gömlek /Liner	Kit 2	Info
<p>ø78,30</p> <p>6 Cyl. Diesel 2496 cc 110kW 150PS 19.5:1 AKN AK KK RT <u>1997 - 2005</u> <u>1.2.3. Sil. PASSAT</u> <u>A4 2.5 TDI 78.31 MM</u></p>	<p>17-7050580 STD 17-7050583 0.50</p>	<p>A = 47,830 B = 71,830 C = 16,500 E = -1,380 CD= 35,800</p>	<p>RE12160000 -STD RE12160025 -0.25 RE12160050 -0.50 RE12160100 -1.00</p> <p>1,200 (500) NitB S IF 1,500 (501) P 2,000 (700) CrPS</p>	<p>ø26,0 x 65,5</p>			
<p>ø78,30</p> <p>6 Cyl. Diesel 2496 cc 110kW 150PS 19.5:1 AKN AK KK RT <u>1997 - 2005</u> <u>4.5. Sil. PASSAT</u> <u>A4 2.5 TDI 78.31 MM</u></p>	<p>17-7050590 STD 17-7050593 0.50</p>	<p>A = 47,830 B = 71,830 C = 16,500 E = -1,380 CD= 35,800</p>	<p>RE12160000 -STD RE12160025 -0.25 RE12160050 -0.50 RE12160100 -1.00</p> <p>1,200 (500) NitB S IF 1,500 (501) P 2,000 (700) CrPS</p>	<p>ø26,0 x 65,5</p>			



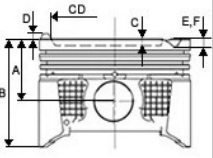



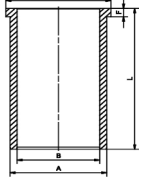
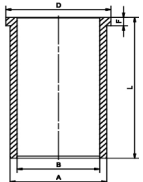

							
Motor /Engine	Ref. No. Kit 1	Ölçüler /Dimensions	Segman /Rings	Pim	Gömlek /Liner	Kit 2	Info
<p>ø79,50</p> <p>4 Cyl. Benzin, 1588 cm³ 58 kW (79 hp), 8,2:1</p> <p>EE EF EJ FN FR WV WVA YG YH YN YP YV</p> <p><u>1974 - 1983</u></p> <p>Audi (80 1.6-100 1.6) VW Golf I 1.6</p> 	<p>18-7010070 STD 18-7010073 0.50</p>	<p>A = 41,800 B = 73,800 C = 6,100 CD= 65,100</p>	<p>RE56150000 -STD RE56150050 -0.50 RE56150100 -1.00</p> <p>1,750 (500) CrB Fe S IF 2,000 (508) P 4,000 (700) Cr P S</p>	<p>ø22,0 x 55,0</p>			
<p>ø79,50</p> <p>4 Cyl. Benzin, 1588 cm³ 81 kW (110 hp), 9,5:1</p> <p>EG</p> <p><u>1976 - 1980</u></p> <p>Golf Gti Cabriolet Scirocco Gti Passat Gti Jetta Gti</p> 	<p>18-7010100 STD 18-7010103 0.50</p>	<p>A = 40,700 B = 72,700 C = 8,300</p>	<p>RE56150000 -STD RE56150050 -0.50 RE56150100 -1.00</p> <p>1,750 (500) CrB Fe S IF 2,000 (508) P 4,000 (700) Cr P S</p>	<p>ø22,0 x 63,0</p>			



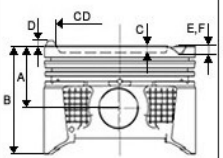



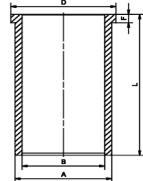

							
Motor /Engine	Ref. No. Kit 1	Ölçüler /Dimensions	Segman /Rings	Pim	Gömlek /Liner	Kit 2	Info
<p>ø79,50</p> <p>4 Cyl. Diesel 1896/... cc 85 Kw 115 Ps 18:1 19:1 Turbo,LLK,8 Ventile AJM ATJ AUY BVK 1.&2.Sil <u>1988 -....</u></p> <p><u>1.&2.Sil</u> A4/A6 1.9 TDI Turbo-LLK-8 Ventile GALAXY I 1.9 TDI ALHAMBRA 1.9 TDI GOLF IV BORA PASSAT SHARAN I 1.9 TDI</p>	<p>18-7050020 STD 18-7050023 0.50 18-7050028 1.00</p>	<p>A = 45,800 B = 69,800 C = 17,800 E = -1,300 F = -1,300 CD= 38,000</p>	<p>RE56160000 -STD RE56160050 -0.50 RE56160100 -1.00</p>	<p>ø26,0 x 66,0</p>			
<p>ø79,50</p> <p>4 Cyl. Diesel 1896/... cc 85 Kw 115 Ps 18:1 19:1 Turbo,LLK,8 Ventile AJM ATJ AUY BVK 3.&4.Sil <u>1988 -....</u></p> <p><u>1.&2.Sil</u> A4/A6 1.9 TDI Turbo-LLK-8 Ventile GALAXY I 1.9 TDI ALHAMBRA 1.9 TDI GOLF IV BORA PASSAT SHARAN I 1.9 TDI</p>	<p>18-7050030 STD 18-7050033 0.50 18-7050038 1.00</p>	<p>A = 45,800 B = 69,800 C = 17,800 E = -1,300 F = -1,300 CD= 38,000</p>	<p>RE56160000 -STD RE56160050 -0.50 RE56160100 -1.00</p>	<p>ø26,0 x 66,0</p>	<p>G83001548K_1</p> <p>A= 83,000 B= 78,810 D= 85,600 F= 5,100 H= 0,000 L= 154,800</p> 		



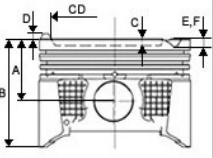



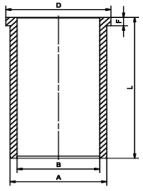

Motor /Engine	Ref. No. Kit 1	Ölçüler /Dimensions	Segman /Rings	Pim	Gömlek /Liner	Kit 2	Info
							
ø79,50 3 Cyl. Diesel 1422 cc 55 Kw (75 Ps) 19.5:1 AMF BAY BWB BHC BNV 1999 -..... 1. & 2. Sil. Polo 1.4 Tdi Lupo 1.4 Tdi Fox 1.4 Tdi Fabia 1.4 TDi	17-7050880 STD 17-7050883 0.50	A = 45,800 B = 69,800 C = 17,650 E = -1,100 CD= 37,900 Segman Taşıyıcı (Ring Carrier) Yag Püskürt. Oyugu (Oil Cut-Out) Burc (Bushing)	RE56160000 -STD RE56160050 -0.50 RE56160100 -1.00 1,750 (500) CrB Fe S 2,000 (501) P IFU 3,000 (604) Cr P S	ø26,0 x 63,0			1,53 mm conta + 0,81 + 0,96 1,57 mm conta + 0,96 + 1,01 1,61 mm conta + 1,01 + 1,03
ø79,50 3 Cyl. Diesel 1422 cc 55 Kw (75 Ps) 19.5: AMF 1999 -..... 3. Sil. Polo 1.4 Tdi Lupo 1.4 Tdi Fox 1.4 Tdi Fabia 1.4 TDi	17-7050890 STD 17-7050893 0.50	A = 45,800 B = 69,800 C = 17,650 E = -1,100 CD= 37,900 Segman Taşıyıcı (Ring Carrier) Yag Püskürt. Oyugu (Oil Cut-Out) Burc (Bushing)	RE56160000 -STD RE56160050 -0.50 RE56160100 -1.00 1,750 (500) CrB Fe S 2,000 (501) P IFU 3,000 (604) Cr P S	ø26,0 x 63,0			1,53 mm conta + 0,81 + 0,96 1,57 mm conta + 0,96 + 1,01 1,61 mm conta + 1,01 + 1,03



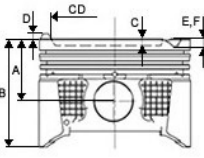







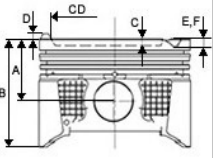

Motor /Engine	Ref. No. Kit 1	Ölçüler /Dimensions	Segman /Rings	Pim	Gömlek /Liner	Kit 2	Info
							
ø79,50 4/5 Cyl. Diesel 1896 cc 44 Kw (60 Ps) 22.5:1 ADG AEF BGG 1 X 1 Y(4 CY) AAB AJA (5 CYL) 1990 - 1995 Golf Polo Passat Caddy Transporter T4 Audi 80 1.9D Audi 100 2.4D Skoda Felicia 1.9D	17-7050920 STD 17-7050923 0.50 17-7050928 1.00	A = 39,650 B = 65,700 C = 1,900 Segman Taşıyıcı (Ring Carrier) Sac Plaka (Steel Support) Yağ Püskürt. Oyugu (Oil Cut-Out)	RE56160000 -STD RE56160050 -0.50 RE56160100 -1.00 1,750 (500) CrB Fe S 2,000 (501) P IFU 3,000 (604) Cr P S	ø24,0 x 64,0	G83001548K_1 A= 83,000 B= 78,810 D= 85,600 F= 5,100 H= 0,000 L= 154,800 	1. çentik 1.53 mm conta + 0,66 + 0,86 2. çentik 1.57 mm conta + 0,87 + 0,90 3. çentik 1.61 mm conta + 0,91 + 1,02	
ø79,50 4 Cyl. Diesel, 1716 cm ³ 42 kW (57 hp), 23:1 KY 1986 - 1992 Transporter T3	18-7050930 STD 18-7050933 0.50 18-7050938 1.00	A = 41,700 B = 67,700 C = 1,600 Segman Taşıyıcı (Ring Carrier)	RE56330000 -STD RE56330050 -0.50 RE56330100 -1.00 1,750 (500) CrB Fe S 2,000 (501) Cr P IFU 3,000 (604) Cr P S	ø24,0 x 64,0			









Motor /Engine	Ref. No. Kit 1	Ölçüler /Dimensions	Segman /Rings	Pim	Gömlek /Liner	Kit 2	Info
							
ø79,50 4 Cyl. Diesel 1896 cc 50 Kw (68 Ps) 22.5:1 AAZ ABL ADE 1992 -..... Transporter T4 Passat 1,9 TD Golf III 1,9 TD Vento 1,9 TD Audi 80 1.9 TD	18-7050940 STD 18-7050943 0.50 18-7050948 1.00	A = 45,650 B = 71,700 C = 1,900	RE56330000 -STD RE56330050 -0.50 RE56330100 -1.00 1,750 (500) CrB Fe S 2,000 (501) Cr P IFU 3,000 (604) Cr P S	ø26,0 x 66,0	G83001548K_1 A= 83,000 B= 78,810 D= 85,600 F= 5,100 H= 0,000 L= 154,800		1.çentik 1.53 mm conta +0,66 +0,86 2.çentik 1.57 mm conta +0,87 +0,90 3.çentik 1.61 mm conta +0,91 +1,02
ø79,50 4 Cyl. Diesel 1896 cc 66 Kw (90 Ps) 19.5:1 1Z AGD AEY AHH AHU AFN AHF 1993 - 1997 1. & 2. Sil. Vento 1,9 Tdi Passat 1,9 Tdi Bora 1,9 Tdi Golf III 1,9 Tdi A3 I 1,9 Tdi A4 1,9 Tdi A6 1,9 Tdi Cabriolet 1,9 Tdi Audi 80 1,9 Tdi Skoda Sporb Tdi Skoda Octavia Tdi	17-7050950 STD 17-7050953 0.50 17-7050958 1.00	A = 45,800 B = 71,800 C = 17,650 E = -1,100 CD= 37,900	RE56160000 -STD RE56160050 -0.50 RE56160100 -1.00 1,750 (500) CrB Fe S 2,000 (501) P IFU 3,000 (604) Cr P S	ø26,0 x 66,0	G83001548K_1 A= 83,000 B= 78,810 D= 85,600 F= 5,100 H= 0,000 L= 154,800		1. çentik 1.45 mm conta + 0,91 + 1,00 2. çentik 1.53 mm conta + 1,00 + 1,10 3. çentik 1.61 mm conta + 1,10 + 1,20



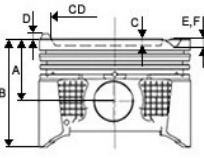





Motor /Engine	Ref. No. Kit 1	Ölçüler /Dimensions	Segman /Rings	Pim	Gömlek /Liner	Kit 2	Info
							
ø79,50 4 Cyl. Diesel 1896 cc 66 Kw (90 Ps) 19.5:1 1Z AGD AEY AHH AHU AFN AHF <u>1993 - 1997</u> 3. & 4. Sil. Vento 1.9 Tdi Passat 1.9 Tdi Bora 1.9 Tdi Golf III 1.9 Tdi A3 1.9 Tdi A4 1.9 Tdi A6 1.9 Tdi Cabriolet 1.9 Tdi Audi 80 1.9 Tdi Skoda Sporb Tdi Skoda Octavia Tdi	17-7050960 STD 17-7050963 0.50 17-7050968 1.00	A = 45,800 B = 71,800 C = 17,650 E = -1,100 CD= 37,900 Segman Taşıyıcı (Ring Carrier) Yag Püskürt. Oyugu (Oil Cut-Out) Burc (Bushing)	RE56160000 -STD RE56160050 -0.50 RE56160100 -1.00 1,750 (500) CrB Fe S 2,000 (501) P IFU 3,000 (604) Cr P S	ø26,0 x 66,0	G83001548K_1 A= 83,000 B= 78,810 D= 85,600 F= 5,100 H= 0,000 L= 154,800 	1. çentik 1.45 mm conta + 0,91 + 1,00 2. çentik 1.53 mm conta + 1,00 + 1,10 3. çentik 1.61 mm conta + 1,10 + 1,20	
ø79,50 4 Cyl. Diesel 1896 cc 47 Kw (64 Ps) 50 Kw (68 Ps) 19,5:1 ASX (1999>) AQM (1997>) AGP (1997>) ASY/AYQ (2001>) <u>1997 -....</u> 1. & 2. Sil Polo SDI Bora SDI Golf SDI	17-7050970 STD 17-7050973 0.50	A = 39,800 B = 60,700 C = 17,750 E = -1,000 CD= 38,000	RE56160000 -STD RE56160050 -0.50 RE56160100 -1.00 1,750 (500) CrB Fe S 2,000 (501) P IFU 3,000 (604) Cr P S	ø24,0 x 59,0			



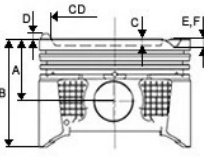



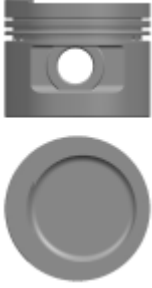
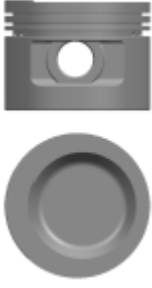

Motor /Engine	Ref. No. Kit 1	Ölçüler /Dimensions	Segman /Rings	Pim	Gömlek /Liner	Kit 2	Info
       							
ø79,50 4 Cyl. Diesel 1896 cc 47 Kw (64 Ps) 50 Kw (68 Ps) 19,5:1 ASX (1999>) AQM (1997>) AGP (1997>) ASY/AYQ (2001>) 1997 -.... 3. & 4. Sil Polo SDI Bora SDI Golf SDI	17-7050980 STD 17-7050983 0.50	A = 39,800 B = 60,700 C = 17,750 E = -1,000 CD= 38,000	RE56160000 -STD RE56160050 -0.50 RE56160100 -1.00 1,750 (500) CrB Fe S 2,000 (501) P IFU 3,000 (604) Cr P S	ø24,0 x 59,0			
ø79,50 4 Cyl. Diesel 1598cc 77KW 105HP CLHA CLHB CRKB 2010 -.... A3 1.6 TDI 16V GOLF VII 1.6 TDI Leon 1.6 TDI Octavia 1.6 TDI 2010 -	18-7092090 STD 18-7092093 0.50	A = 45,300 B = 68,130 C = 11,000 CD= 49,000 Segman Taşıyıcı (Ring Carrier) Yag Galerisi (Oil Gallery) Yag Püskürt. Oyugu (Oil Cut-Out)	RE56140000 -STD RE56140050 -0.50 1,750 (500) Cr P 2,000 (501) P IF 2,000 (604) Nit S	ø26,0 x 66,0	G83001548K_1 A= 83,000 B= 78,810 D= 85,600 F= 5,100 H= 0,000 L= 154,800		

							
Motor /Engine	Ref. No. Kit 1	Ölçüler /Dimensions	Segman /Rings	Pim	Gömlek /Liner	Kit 2	Info
<p>ø79,51</p> <p>3/4 Cyl. Diesel 1199 cc/1598cc 55/66 77 Kw 75/90/102/105 ps CAYB CAYC CFWA CLNA CAYA CAYD CAYE CFWA <u>2009 -....</u></p> <p><i>Polo 1.2 Tdi (3 cyl) Polo 1.6 TDI 16V 4 cyl 2009 - 2014</i></p>	<p>17-7092500 STD <i>17-7092500-20 STD (-0.20 mm)</i></p> <p>17-7092503 0.50 <i>17-7092503-20 0.50 (-0.20 mm)</i></p>	<p>A = 45,300 B = 67,900 C = 10,700 CD= 49,000</p> <p>Segman Taşıyıcı (Ring Carrier)</p> <p>Yag Galerisi (Oil Gallery)</p>	<p>RE56160000 -STD RE56160050 -0.50 RE56160100 -1.00</p> <p>1,750 (500) CrB Fe S 2,000 (501) P IFU 3,000 (604) Cr P S</p>	<p>ø26,0 x 66,0</p>			
<p>ø79,51</p> <p>3 Cyl. Diesel 1422 cc 55/66/77 KW 75/90/105 PS CUSB CUSA CUTA CYZA CYZB <u>2014 -</u></p> <p><i>Polo 14 TDI</i></p>	<p>17-7092600 STD <i>17-7092600-20 STD (-0.20 mm)</i></p> <p>17-7092603 0.50 <i>17-7092603-20 0.50 (-0.20 mm)</i></p>	<p>A = 45,800 B = 68,800 C = 13,600 CD= 49,000</p> <p>Segman Taşıyıcı (Ring Carrier)</p> <p>Yag Galerisi (Oil Gallery)</p>	<p>RE12320000 -STD RE12320050 -0.50</p> <p>1,750 (500) CrP 2,000 (501) PIFU 2,000 (604) CrP</p>	<p>ø26,0 x 66,0</p>			

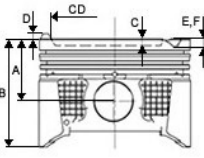









Motor /Engine	Ref. No. Kit 1	Ölçüler /Dimensions	Segman /Rings	Pim	Gömlek /Liner	Kit 2	Info
							
ø79,51 4 Cyl. Diesel 1896 cc 74 Kw (101 Ps) AVQ ATD AXR AVB BJB SERİSİ OIL GALERY VAR 2004 -.... 1.ve 2. Sil. Caddy III TDI Touran TDI Bora TDI Golf TDI Polo TDI Passat TDI	17-7092750 STD 17-7092753 0.50	A = 45,800 B = 68,800 C = 17,100 E = -0,650 CD= 38,000 Segman Taşıyıcı (Ring Carrier) Yag Galerisi (Oil Gallery) Yag Püskürt. Oyugu (Oil Cut-Out) Burc (Bushing)	RE56330000 -STD RE56330050 -0.50 RE56330100 -1.00 1,750 (500) CrB Fe S 2,000 (501) Cr P IFU 3,000 (604) Cr P S	ø26,0 x 66,0		 	1,45 mm conta +0,91 +1,00 1,53 mm conta +1,01 +1,10 1,61 mm conta +1,11 +1,20
ø79,51 4 Cyl. Diesel 1896 cc 74 Kw (101 Ps) AVQ ATD AXR AVB BJB SERİSİ OIL GALERY VAR 2004 -.... 3.ve 4. Sil. Caddy III TDI Touran TDI Bora TDI Golf TDI Polo TDI Passat TDI	17-7092760 STD 17-7092763 0.50	A = 45,800 B = 68,800 C = 17,100 E = -0,650 CD= 38,000 Segman Taşıyıcı (Ring Carrier) Yag Galerisi (Oil Gallery) Yag Püskürt. Oyugu (Oil Cut-Out) Burc (Bushing)	RE56330000 -STD RE56330050 -0.50 RE56330100 -1.00 1,750 (500) CrB Fe S 2,000 (501) Cr P IFU 3,000 (604) Cr P S	ø26,0 x 66,0		 	1,45 mm conta +0,91 +1,00 1,53 mm conta +1,01 +1,10 1,61 mm conta +1,11 +1,20

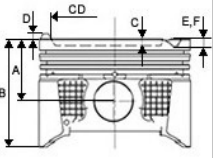







							
Motor /Engine	Ref. No. Kit 1	Ölçüler /Dimensions	Segman /Rings	Pim	Gömlek /Liner	Kit 2	Info
<p>ø79,51</p> <p>4 Cyl. Diesel 1896 cc 110 Kw (150 Ps) ARL ASZ AXB AXC AXB EUR3 2000 -....</p> <p>1. & 2. Sil. Bora PDI Golf PDI Bora TDI Golf TDI Multi Van Transporter Transporter TDI</p>	<p>17-7092770 STD 17-7092773 0.50</p>	<p>A = 45,800 B = 68,800 C = 17,900 E = -1,100 CD= 38,000</p> <p>Segman Taşıyıcı (Ring Carrier)</p> <p>Yag Galerisi (Oil Gallery)</p> <p>Yag Püskürt. Oyugu (Oil Cut-Out)</p> <p>Burc (Bushing)</p>	<p>RE56160000 -STD RE56160050 -0.50 RE56160100 -1.00</p> <p>1,750 (500) CrB Fe S 2,000 (501) P IFU 3,000 (604) Cr P S</p>	<p>ø26,0 x 66,0</p>			<p>1,45 mm conta +0,91 +1,00</p> <p>1,53 mm conta +1,01 +1,10</p> <p>1,61 mm conta +1,11 +1,20</p>
<p>ø79,51</p> <p>4 Cyl. Diesel 1896 cc 110 Kw (150 Ps) ARL ASZ AXB AXC AXB EUR3 2000 -....</p> <p>3. & 4. Sil. Bora PDI Golf PDI Bora TDI Golf TDI Multi Van Transporter Transporter TDI</p>	<p>17-7092780 STD 17-7092783 0.50</p>	<p>A = 45,800 B = 68,800 C = 17,900 E = -1,100 CD= 38,000</p> <p>Segman Taşıyıcı (Ring Carrier)</p> <p>Yag Galerisi (Oil Gallery)</p> <p>Yag Püskürt. Oyugu (Oil Cut-Out)</p> <p>Burc (Bushing)</p>	<p>RE56160000 -STD RE56160050 -0.50 RE56160100 -1.00</p> <p>1,750 (500) CrB Fe S 2,000 (501) P IFU 3,000 (604) Cr P S</p>	<p>ø26,0 x 66,0</p>			



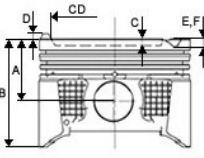





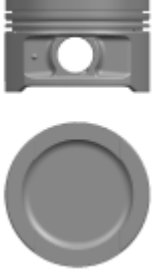
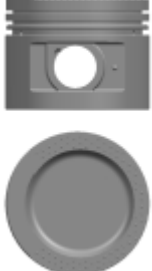

							
Motor /Engine	Ref. No. Kit 1	Ölçüler /Dimensions	Segman /Rings	Pim	Gömlek /Liner	Kit 2	Info
<p>ø81,00</p> <p>4 Cyl. Benzin, 1595 cm³ 53/55 kW (72/75 hp)</p> <p>ABN DT EW EZ ABX ACR DTA EZA HM</p> <p><u>1991 -....</u></p> <p>Golf Jetta Passat Audi 80 1.6</p> 	<p>18-7010160 STD 18-7010163 0.50</p>	<p>A = 35,600 B = 58,500 C = 2,300 D = 0,700</p>	<p>RE56180000 -STD RE56180050 -0.50 RE56180100 -1.00</p> <p>1,500 (500) CrB S IF 1,750 (508) P 3,000 (700) Cr P S</p>	<p>ø20,0 x 57,0</p>			
<p>ø81,00</p> <p>4 Cyl. Benzin, 1781 cm³ 55 kW (75 hp)</p> <p>AMM ANN ACC ADD RP</p> <p><u>1983 - 1996</u></p> <p>Golf 1.8 Jetta II 1.8 Passat 1.8 Audi 80 1.8 audi 80 1.8 cc Audi 80 1.8 s Audi 100 1.8 Audi Coupe 1.8 Audi Coupe 1.8 GT</p> 	<p>18-7010170 STD 18-7010173 0.50</p>	<p>A = 32,200 B = 62,500 C = 8,100 D = 1,300 CD= 56,800</p>	<p>RE56190000 -STD RE56190050 -0.50</p> <p>1,500 (500) CrB S IF 1,750 (508) P 3,000 (604) Cr</p>	<p>ø20,0 x 57,0</p>			

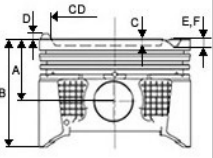





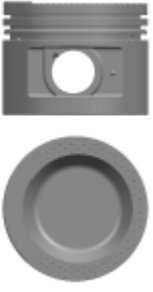
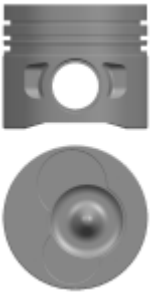

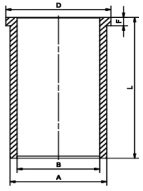

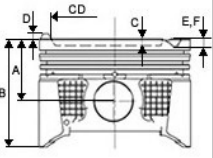

							
Motor /Engine	Ref. No. Kit 1	Ölçüler /Dimensions	Segman /Rings	Pim	Gömlek /Liner	Kit 2	Info
<p>ø81,00</p> <p>5 Cyl. Benzin, 2226 cm³ 101 kW (137 hp), 10:1 HY KV JT KX KM <u>1984 - 1990</u> Passat</p>	<p>17-7010200 STD</p>	<p>A = 32,200 B = 62,300 C = 4,600 D = 1,100 CD= 60,000</p> <p>Sac Plaka (Steel Support)</p>	<p>RE56180000 -STD RE56180050 -0.50 RE56180100 -1.00</p> <p>1,500 (500) CrB S IF 1,750 (508) P 3,000 (700) Cr P S</p>	<p>ø20,0 x 57,0</p>			
<p>ø81,00</p> <p>4 Cyl. Benzin 1781 cc 72 Kw (98 Ps) ABS ADZ DS DX DZ EV GZ HT <u>1988 - 1991</u> Golf I 1.8i Jetta II 1.8 Passat 1.8 Audi 80 1.8 Audi 100 1.8 Quattro Coupe 1.8 GT</p>	<p>18-7010210 STD 18-7010213 0.50</p>	<p>A = 32,200 B = 62,500 C = 5,700 D = 1,300 CD= 55,700</p> <p>Sac Plaka (Steel Support)</p>	<p>RE56190000 -STD RE56190050 -0.50</p> <p>1,500 (500) CrB S IF 1,750 (508) P 3,000 (604) Cr</p>	<p>ø20,0 x 57,0</p>			





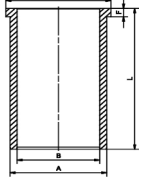

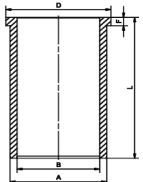





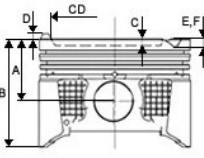



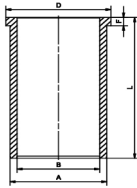

Motor /Engine	Ref. No. Kit 1	Ölçüler /Dimensions	Segman /Rings	Pim	Gömlek /Liner	Kit 2	Info
       							
ø81,00 4 Cyl. Benzin 1781 cc 110 Kw (150 Ps) AEB AGU AJH ANB APH APU AQA ARZ AVC <u>1996 -....</u> Golf VI 1,8 t Bora 1,8 t Passat 1,8 t Audi A3 1.8 T Audi A4 1.8 T Audi A6 1.8 T Audi TT 1.8 T Skoda Octavia Turbo	18-7010220 STD 18-7010221 0.25 18-7010223 0.50	A = 32,700 B = 53,700 C = 1,500 CD= 70,200	RE56380000 -STD RE56380025 -0.25 RE56380050 -0.50 RE56380100 -1.00 1,500 (500) CrBFeSIF 1,750 (508) P 2,000 (700) NitS	ø20,0 x 59,0			
							
ø81,00 4 Cyl. Benzin 1781cc 110 Kw (150 Hp) ARX AUM AUQ AWM AWP AWT AWU AWW BJX BKF BNU AWP BE <u>2000 - 2001</u> Leon Toledo Ibiza Octavia Bora Golf IV Passat Jetta New Beetle	18-7010250 STD 18-7010253 0.50	A = 32,700 B = 53,700 C = 1,900 CD= 69,200 Sert Anotlama (Hard Anodising) Yag Püskürt. Oyugu (Oil Cut-Out)	RE56380000 -STD RE56380025 -0.25 RE56380050 -0.50 RE56380100 -1.00 1,500 (500) CrBFeSIF 1,750 (508) P 2,000 (700) NitS	ø19,0 x 50,0			
							



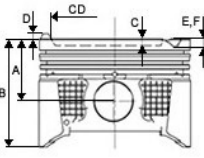



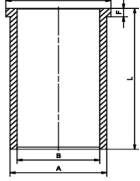
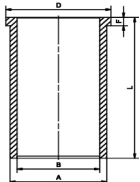

							
Motor /Engine	Ref. No. Kit 1	Ölçüler /Dimensions	Segman /Rings	Pim	Gömlek /Liner	Kit 2	Info
<p>ø81,00</p> <p>4 Cyl. Benzin 1595 cc 75 Kw (102 Ps) ADP AEH AEK AFT AHL AKL <u>1996 - 1997</u></p> <p><i>Golf VI 1,6 Golf III 1,6 Passat 1,6 Vento 1,6 Audi A3cl 1,6 l Audi A4 1,6 Skoda Octavia</i></p> 	<p>18-7010350 STD 18-7010353 0.50 18-7010358 1.00</p>	<p>A = 32,000 B = 53,700 C = 3,000 E = -0,700 CD= 62,500</p>	<p>RE56370000 -STD RE56370050 -0.50 RE56370100 -1.00</p> <p>1,200 (500) NitB S IF 1,500 (508) P 2,000 (700) Nit S</p>	<p>ø20,0 x 57,0</p>			
<p>ø81,00</p> <p>5 Cyl. Benzin, 2459 cm³ 85 kW (115 hp) ACU AVT APL AET <u>1996 - 2003</u></p> <p><i>Transporter T4 2,5</i></p> 	<p>17-7010800 STD 17-7010803 0.50</p>	<p>A = 38,350 B = 64,350 C = 4,600 CD= 62,000</p>	<p>RE56180000 -STD RE56180050 -0.50 RE56180100 -1.00</p> <p>1,500 (500) CrB S IF 1,750 (508) P 3,000 (700) Cr P S</p>	<p>ø24,0 x 56,0</p>			

Motor /Engine	Ref. No. Kit 1	Ölçüler /Dimensions	Segman /Rings	Pim	Gömlek /Liner	Kit 2	Info
       							
ø81,00 4 Cyl. Benzin, 1998 cm ³ 62 kW (84 hp), 8,5:1 AAC AAF AEU 1990 -.... Transporter T4 2,0 Transporter T4 2,5	18-7010810 STD 18-7010813 0.50	A = 38,500 B = 65,450 C = 10,500 D = 1,100 CD= 62,000	RE56170000 -STD RE56170050 -0.50 RE56170100 -1.00 1,750 (500) CrB Fe S IF 2,000 (508) P 3,000 (700) Cr P S	ø24,0 x 56,0			
							
ø81,00 5 Cyl. Diesel 2459 cc 55 Kw (75 Ps) AGX ANF AJT APA AYY BBE ACV AHD AUF AXL 1996 - 2001 1. & 2. Sil. T4 Tdi LT 35 Tdi LT 28 Tdi Caravelle CL/GL Caravelle Club, Caravelle Variant Trans porter	17-7050840 STD 17-7050843 0.50	A = 45,750 B = 69,750 C = 17,200 E = -1,400 CD= 39,700	RE56410000 -STD RE56410050 -0.50 RE56410100 -1.00 2,500 (500) Cr P 2,000 (501) P 3,000 (604) Cr P	ø26,0 x 68,0	G84001580K_1 A= 84,000 B= 80,300 D= 85,000 F= 5,000 H= 0,000 L= 158,000	  	1.çentik 1.53 mm conta +0,80 +0,90 2.çentik 1.57 mm conta +0,90 +1,00 3.çentik 1.61 mm conta +1,00 +1,10
		Segman Taşıyıcı (Ring Carrier) Sert Anotlama (Hard Anodising) Yag Püskürt. Oyugu (Oil Cut-Out) Burc (Bushing)					

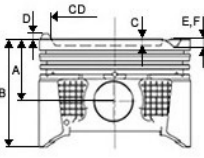







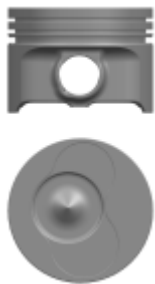

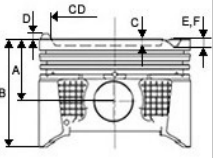

Motor /Engine	Ref. No. Kit 1	Ölçüler /Dimensions	Segman /Rings	Pim	Gömlek /Liner	Kit 2	Info
							
ø81,00 5 Cyl. Diesel 2459 cc 55 Kw (75 Ps) AGX ANF AJT APA AYY BBE ACV AHD AUF AXL <u>1996 - 2001</u> 3.4. & Sil. T4 Tdi LT 35 Tdi LT 28 Tdi Caravelle CL/GL Caravelle Club Caravelle Variant Trans porter	17-7050850 STD 17-7050853 0.50	A = 45,750 B = 69,750 C = 17,200 E = -1,400 CD= 39,700 Segman Taşıyıcı (Ring Carrier) Sert Anotlama (Hard Anodising) Yag Püskürt. Oyugu (Oil Cut-Out) Burc (Bushing)	RE56410000 -STD RE56410050 -0.50 RE56410100 -1.00 2,500 (500) Cr P 2,000 (501) P 3,000 (604) Cr P	ø26,0 x 68,0	G84001580K_1 A= 84,000 B= 80,300 D= 85,000 F= 5,000 H= 0,000 L= 158,000 		1.çentik 1.53 mm conta +0,80 +0,90 2.çentik 1.57 mm conta +0,90 +1,00 3.çentik 1.61 mm conta +1,00 +1,10
ø81,00 4 Cyl. Diesel 1968 cc 140 KW (190 PS) CNHA CNHC CZJA DETA DETB <u>2008 -....</u> AUDI 2.0TDI	18-7054320 STD 18-7054323 0.50	A = 45,800 B = 68,800 C = 13,500 CD= 50,880 Segman Taşıyıcı (Ring Carrier) Yag Galerisi (Oil Gallery) Burc (Bushing)	RK56281010010 -STD RK56281010013 -0.50 1,750 () Cr 2,000 () IF 2,000 ()	ø26,0 x 66,0	G84001580K_1 A= 84,000 B= 80,300 D= 85,000 F= 5,000 H= 0,000 L= 158,000 		









							
Motor /Engine	Ref. No. Kit 1	Ölçüler /Dimensions	Segman /Rings	Pim	Gömlek /Liner	Kit 2	Info
<p>ø81,00</p> <p>4 Cyl. Diesel 1968 cc 150 KW (204 PS) 16Valf CXEC CXEB <u>2016 -....</u> TRANSPORTER T6 2.0 TDI</p>	<p>18-7094370 STD 18-7094373 0.50</p>	<p>A = 45,800 B = 70,300 C = 13,150 CD= 50,900</p> <p>Segman Taşıyıcı (Ring Carrier)</p> <p>Yag Galerisi (Oil Gallery)</p> <p>Yag Püskürt. Oyugu (Oil Cut-Out)</p> <p>Burc (Bushing)</p>	<p>RK56281010010 -STD RK56281010013 -0.50</p> <p>1,750 () Cr 2,000 () IF 2,000 ()</p>	<p>ø29,0 x 63,0</p>			
<p>ø81,00</p> <p>4 Cyl. Diesel 2000 cc 100 120 KW/136 163 HP CKTC CKUC CKUB CKTB <u>2010 -....</u> Crafter 2.0 TDI Amarok 2010 -</p>	<p>18-7094400 STD 18-7094403 0.50</p>	<p>A = 45,800 B = 68,800 C = 13,100 CD= 50,880</p> <p>Segman Taşıyıcı (Ring Carrier)</p> <p>Yag Galerisi (Oil Gallery)</p> <p>Yag Püskürt. Oyugu (Oil Cut-Out)</p> <p>Burc (Bushing)</p>	<p>RE56400000 -STD RE56400025 -0.25 RE56400050 -0.50 RE56400100 -1.00</p> <p>1,750 (500) CrB Fe S IF 2,000 (508) P 3,000 (604) Cr P</p>	<p>ø26,0 x 66,0</p>	<p>G84001580K_1</p> <p>A= 84,000 B= 80,300 D= 85,000 F= 5,000 H= 0,000 L= 158,000</p>		



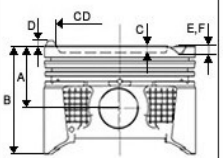





							
Motor /Engine	Ref. No. Kit 1	Ölçüler /Dimensions	Segman /Rings	Pim	Gömlek /Liner	Kit 2	Info
<p>ø81,00</p> <p>4 Cyl. Diesel 1968 cc 100 103 KW/136 140 PS BGW BMM BMP BRT BSS <u>2003 -....</u></p> <p><i>1. & 2. Sil. Caddy III BOX 2.0 TDI Golf VI 2.0 TDI Jetta III 2.0 TDI 2003 -</i></p>	<p>17-7094770 STD 17-7094773 0.50</p>	<p>A = 45,000 B = 68,800 C = 17,500 E = -0,700 CD= 38,000</p> <p>Segman Taşıyıcı (Ring Carrier)</p> <p>Yag Galerisi (Oil Gallery)</p> <p>Yag Püskürt. Oyugu (Oil Cut-Out)</p> <p>Burc (Bushing)</p>	<p>RE56400000 -STD RE56400025 -0.25 RE56400050 -0.50 RE56400100 -1.00</p> <p>1,750 (500) CrB Fe S IF 2,000 (508) P 3,000 (604) Cr P</p>	<p>ø26,0 x 66,0</p>	<p>G84001580K_1</p> <p>A= 84,000 B= 80,300 D= 85,000 F= 5,000 H= 0,000 L= 158,000</p> 		
<p>ø81,00</p> <p>4 Cyl. Diesel 1968 cc 100 103 KW/136 140 PS BGW BMM BMP BRT BSS <u>2003 -....</u></p> <p><i>3. & 4. Sil. Caddy III BOX 2.0 TDI Golf VI 2.0 TDI Jetta III 2.0 TDI 2003 -</i></p>	<p>17-7094780 STD 17-7094783 0.50</p>	<p>A = 45,800 B = 68,800 C = 17,500 E = -0,700 CD= 38,000</p> <p>Segman Taşıyıcı (Ring Carrier)</p> <p>Yag Galerisi (Oil Gallery)</p> <p>Yag Püskürt. Oyugu (Oil Cut-Out)</p> <p>Burc (Bushing)</p>	<p>RE56400000 -STD RE56400025 -0.25 RE56400050 -0.50 RE56400100 -1.00</p> <p>1,750 (500) CrB Fe S IF 2,000 (508) P 3,000 (604) Cr P</p>	<p>ø26,0 x 66,0</p>	<p>G84001580K_1</p> <p>A= 84,000 B= 80,300 D= 85,000 F= 5,000 H= 0,000 L= 158,000</p> 		



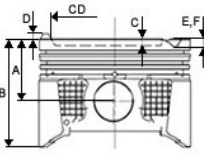



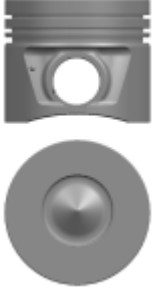
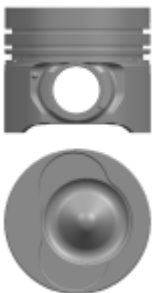

							
Motor /Engine	Ref. No. Kit 1	Ölçüler /Dimensions	Segman /Rings	Pim	Gömlek /Liner	Kit 2	Info
<p>ø81,01</p> <p>4 Cyl. Benzin 1598 cc 75 Kw (102 Ps) BFQ ALZ AVU BSE BSF BGU <u>2002 - 2006</u></p> <p>1.6 GOLF PASSAT JETTA A3 LEON</p>	<p>18-7010240 STD 18-7010243 0.50</p>	<p>A = 29,780 B = 50,700 C = 2,700 D = 0,200 CD= 62,300</p>	<p>RE56440000 -STD RE56440050 -0.50 RE56440100 -1.00</p> <p>1,000 (500) NitB S 1,200 (508) P 2,000 (700) Nit S</p>	<p>ø19,0 x 42,0</p>			<p>+ 0,60 + 0,65</p>
<p>ø81,01</p> <p>4 Cyl. Diesel 1968 cc 69 Ps BDJ BDK BST <u>2004 -....</u></p> <p>1. & 2. Sil. Caddy 2.0 SDI</p>	<p>18-7050780 STD 18-7050783 0.50</p>	<p>A = 37,800 B = 58,800 C = 17,350 E = -0,700 CD= 38,000</p> <p>Segman Taşıyıcı (Ring Carrier)</p>	<p>RE56400000 -STD RE56400025 -0.25 RE56400050 -0.50 RE56400100 -1.00</p> <p>1,750 (500) CrB Fe S IF 2,000 (508) P 3,000 (604) Cr P</p>	<p>ø22,0 x 60,0</p>			<p>1.Çentik conta +0,91 +1,00</p> <p>2.Çentik conta +1,01 +1,10</p> <p>3.Çentik conta +1,11 +1,20</p>



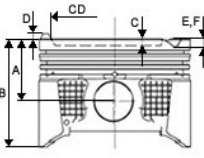





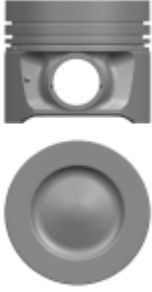
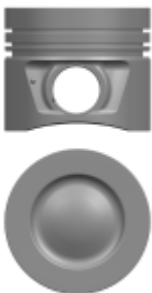



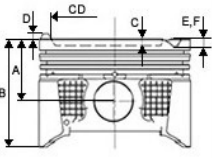



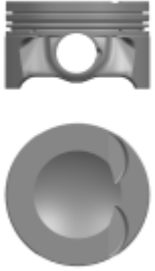

Motor /Engine	Ref. No. Kit 1	Ölçüler /Dimensions	Segman /Rings	Pim	Gömlek /Liner	Kit 2	Info
							
ø81,01 4 Cyl. Diesel 1968 cc 69 Ps BDJ BDK BST <u>2004 -....</u> 3. & 4. Sil. Caddy 2.0 SDi	18-7050790 STD 18-7050793 0.50	A = 37,800 B = 58,800 C = 17,350 E = -0,700 CD= 38,000 Segman Taşıyıcı (Ring Carrier)	RE56400000 -STD RE56400025 -0.25 RE56400050 -0.50 RE56400100 -1.00 1,750 (500) CrB Fe S IF 2,000 (508) P 3,000 (604) Cr P	ø22,0 x 60,0			1.Çentik conta +0,91 +1,00 2.Çentik conta +1,01 +1,10 3.Çentik conta +1,11 +1,20
 							
ø81,01 5 Cyl. Diesel 2461 cc 80 Kw (109 Ps) 19.5: AVR BBR <u>2004 -....</u> A6 2.5TDI	17-7071770 STD 17-7071773 0.50	A = 45,800 B = 69,800 C = 16,800 E = -1,350 CD= 46,000 Segman Taşıyıcı (Ring Carrier) Yag Püskürt. Oyugu (Oil Cut-Out) Burc (Bushing)	RE56410000 -STD RE56410050 -0.50 RE56410100 -1.00 2,500 (500) Cr P 2,000 (501) P 3,000 (604) Cr P	ø26,0 x 68,0			0 +0,75 1 kertik conta +0,87 +0,96 2 kertik conta +0,97 +1,01 3 kertik conta +1,02 +1,10
		 					

Motor /Engine	Ref. No. Kit 1	Ölçüler /Dimensions	Segman /Rings	Pim	Gömlek /Liner	Kit 2	Info
							
ø81,01 5 Cyl. Diesel 2460 cc 96/128 Kw (130 Ps) 1.ve 2.Sil.AXD AXE BLJ Euro 3 BNZ 2004 -.... 1. & 2. Sil. Transporter T5	17-7092820 STD 17-7092823 0.50	A = 45,750 B = 69,750 C = 18,200 E = -1,400 CD= 37,800 Segman Taşıyıcı (Ring Carrier) Yag Galerisi (Oil Gallery) Yag Püskürt. Oyugu (Oil Cut-Out) Burc (Bushing)	RE56410000 -STD RE56410050 -0.50 RE56410100 -1.00 2,500 (500) Cr P 2,000 (501) P 3,000 (604) Cr P	ø26,0 x 66,0			1 kertik conta +0,80 +0,90 2 kertik conta +0,90 +1,00 3 kertik conta +1,00 +1,10
ø81,01 5 Cyl. Diesel 2460 cc 96/128 Kw (130 Ps) 3.4.&5.Sil.AXD AXE BLJ Euro 3 BNZ 2004 -.... 3.4. & 5. Sil. Transporter T5	17-7092830 STD 17-7092833 0.50	A = 45,750 B = 69,750 C = 18,200 E = -1,400 CD= 37,800 Segman Taşıyıcı (Ring Carrier) Yag Galerisi (Oil Gallery) Yag Püskürt. Oyugu (Oil Cut-Out) Burc (Bushing)	RE56410000 -STD RE56410050 -0.50 RE56410100 -1.00 2,500 (500) Cr P 2,000 (501) P 3,000 (604) Cr P	ø26,0 x 66,0			1 kertik conta +0,80 +0,90 2 kertik conta +0,90 +1,00 3 kertik conta +1,00 +1,10

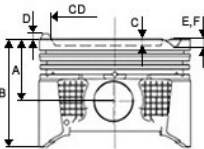







							
Motor /Engine	Ref. No. Kit 1	Ölçüler /Dimensions	Segman /Rings	Pim	Gömlek /Liner	Kit 2	Info
<p>ø81,01</p> <p>4 Cyl. Diesel 2000 cc 140 Ps BKP BVE BMA BMN BMR BUZ BWV <u>2005 -....</u></p> <p>Passat 2.0 TDi Jetta 2.0 TDi Golf V 2.0 TDi</p>	<p>18-7092840 STD 18-7092843 0.50</p> 	<p>A = 45,800 B = 68,800 C = 17,800 CD= 38,000</p> <p>Segman Taşıyıcı (Ring Carrier)</p> <p>Yag Galerisi (Oil Gallery)</p> <p>Yag Püskürt. Oyugu (Oil Cut-Out)</p> <p>Burc (Bushing)</p>	<p>RE56400000 -STD RE56400025 -0.25 RE56400050 -0.50 RE56400100 -1.00</p> <p>1,750 (500) CrB Fe S IF 2,000 (508) P 3,000 (604) Cr P</p>	<p>ø26,0 x 66,0</p>			
<p>ø81,01</p> <p>5 Cyl. Diesel 2459cc 100 Kw (136 Ps) BJM CECB BJL Euro4 BJM Euro4 CECA Euro5 <u>2006 -....</u></p> <p>LT 28 LT 35 LT 46 Crafter-LT 28 D LT 35 D LT 46 D</p>	<p>17-7092850 STD 17-7092853 0.50</p> 	<p>A = 45,750 B = 69,750 C = 16,600 E = -1,350 CD= 45,900</p> <p>Segman Taşıyıcı (Ring Carrier)</p> <p>Yag Galerisi (Oil Gallery)</p> <p>Yag Püskürt. Oyugu (Oil Cut-Out)</p> <p>Burc (Bushing)</p>	<p>RE56410000 -STD RE56410050 -0.50 RE56410100 -1.00</p> <p>2,500 (500) Cr P 2,000 (501) P 3,000 (604) Cr P</p>	<p>ø26,0 x 66,0</p>			

							
Motor /Engine	Ref. No. Kit 1	Ölçüler /Dimensions	Segman /Rings	Pim	Gömlek /Liner	Kit 2	Info
<p>ø81,01</p> <p>4 Cyl. Diesel 1968 cc 110 KW (150 PS) CXHA DAUB DAWA DASA <u>2015 -</u> TRANSPORTER MULTIVAN 2.0 TDI</p>	<p>18-7094340 STD 18-7094343 0.50</p> 	<p>A = 45,800 B = 68,800 C = 13,300 CD= 50,880</p> <p>Segman Taşıyıcı (Ring Carrier)</p> <p>Yag Galerisi (Oil Gallery)</p> <p>Burc (Bushing)</p>	<p>RK56281010010 -STD RK56281010013 -0.50</p> <p>1,750 () Cr 2,000 () IF 2,000 ()</p>	<p>ø26,0 x 66,0</p>			
<p>ø81,01</p> <p>4 Cyl. Diesel 1968 cc 88/90/100/103 105/120/125 KW 84/110/114/120/136 140/143/163/170 PS 16,5:1 CJAA CFHB CFHC CFHE CFJA CAGA/B/C CAHA/B CBAA/BB CAAA/B/C/D/E CBDA/B/C <u>2005 -</u> Golf VI 2.0TDI Jetta IV 2.0TDI Caddy III 2.0TDI Touran 2.0TDI 2005 -</p>	<p>18-7094490 STD 18-7094493 0.50</p> 	<p>A = 45,800 B = 68,800 C = 12,700 CD= 50,880</p> <p>Segman Taşıyıcı (Ring Carrier)</p> <p>Yag Galerisi (Oil Gallery)</p> <p>Yag Püskürt. Oyugu (Oil Cut-Out)</p> <p>Burc (Bushing)</p>	<p>RE56400000 -STD RE56400025 -0.25 RE56400050 -0.50 RE56400100 -1.00</p> <p>1,750 (500) CrB Fe S IF 2,000 (508) P 3,000 (604) Cr P</p>	<p>ø26,0 x 66,0</p>			

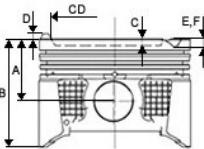





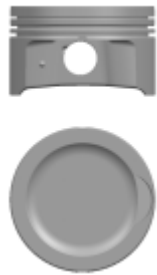

Motor /Engine	Ref. No. Kit 1	Ölçüler /Dimensions	Segman /Rings	Pim	Gömlek /Liner	Kit 2	Info
							
ø81,01 4 Cyl. Diesel 1968 cc 89 120KW/121 170 HP BKD BLB BNA BMN 2003 -.... GOLF V 2.0 TDI JETTA III 2.0 TDI TOURAN 2.0 TDI 2003 -	18-7094670 STD 18-7094673 0.50	A = 48,800 B = 69,800 C = 17,800 CD= 38,000 Segman Taşıyıcı (Ring Carrier) Yag Galerisi (Oil Gallery) Yag Püskürt. Oyugu (Oil Cut-Out) Burc (Bushing)	RE56400000 -STD RE56400025 -0.25 RE56400050 -0.50 RE56400100 -1.00 1,750 (500) CrB Fe S IF 2,000 (508) P 3,000 (604) Cr P	ø26,0 x 66,0			
ø82,50 4 Cyl. Benzin 1984 cc 110/118/125/147 132/155/165 KW 150/160/170/200 204/211/225 PS GÜÇLENDİRİLMİŞ CAWB CCZA/B/D CAEA/B/D CBFA CCTA CFPA/KA CJKA/B CESA CETA MPMA/B CAWA/B 2007 - ... VW GOLF V-VII JETTA III SCIROCCO A...50	18-7010290 STD 18-7010293 0.50	A = 29,600 B = 50,100 C = 6,200 F = -3,800 CD= 50,250 Segman Taşıyıcı (Ring Carrier)	RE56120000 -STD RE56120050 -0.50 1,200 (500) NitB S IF 1,200 (508) P 2,000 (700) 2 (700) Nit S	ø23,0 x 51,0			
							



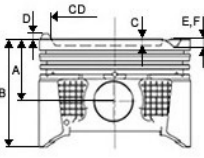





							
Motor /Engine	Ref. No. Kit 1	Ölçüler /Dimensions	Segman /Rings	Pim	Gömlek /Liner	Kit 2	Info
<p>ø82,50</p> <p>4 Cyl. Diesel 1798 cc 125 KW (170 PS) CJEB EURO5 CJED/EE/SA/SB EURO 6 CYGA DAJB DAJA <u>2011 - 2015</u> A4 B8 (8K2) 1.8 TFSI</p>	<p>18-7010390 STD 18-7010393 0.50</p>	<p>A = 29,800 B = 55,980 C = 4,750 D = 5,680 E = -3,470</p> <p>Segman Taşıyıcı (Ring Carrier)</p>	<p>RE56120000 -STD RE56120050 -0.50</p> <p>1,200 (500) NitB S IF 1,200 (508) P 2,000 (700) 2 (700)Nit S</p>	<p>ø23,0 x 51,0</p>			
<p>ø82,50</p> <p>4 Cyl. Benzin 1781cc/1791cc 88/118/125kw 120/160/170ps BZB BYT CABA CABB CABD <u>2006 - 2008</u> A3 1.8 TFSI 16V</p>	<p>18-7010400 STD 18-7010403 0.50</p>	<p>A = 29,800 B = 55,980 C = 6,000 D = 4,750 CD= 67,000</p> <p>Segman Taşıyıcı (Ring Carrier)</p>	<p>RE12160000 -STD RE12160025 -0.25 RE12160050 -0.50 RE12160100 -1.00</p> <p>1,200 (500) NitB S IF 1,500 (501) P 2,000 (700) CrPS</p>	<p>ø21,0 x 53,0</p>			



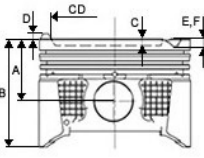





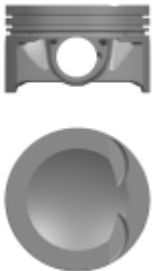



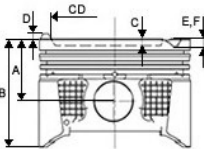





							
Motor /Engine	Ref. No. Kit 1	Ölçüler /Dimensions	Segman /Rings	Pim	Gömlek /Liner	Kit 2	Info
<p>ø82,50</p> <p>4 Cyl. Benzin 1984 cc 96 KW 131 PS ALT <u>2000 -....</u></p> <p><i>Passat 2.0i 20V 2000 -</i></p>	<p>18-7010480 STD</p> <p>18-7010483 0.50</p>	<p>A = 29,600 B = 50,600 C = 2,600 CD= 64,000</p>	<p>RE12160000 -STD RE12160025 -0.25 RE12160050 -0.50 RE12160100 -1.00</p> <p>1,200 (500) NitB S IF 1,500 (501) P 2,000 (700) CrPS</p>	<p>ø19,0 x 44,0</p>			
<p>ø82,50</p> <p>4 Sil 1984 cc 85 kW 115/116 PS 10,4:1 10,5:1 ,8 Ventile AEG APK AQY <u>1998-2008</u></p> <p><i>2,0 Bora GolfIV New Beetle I Fabia Octavia</i></p>	<p>18-7010990 STD</p> <p><i>18-7010990-20 STD (-0.20 mm)</i></p> <p><i>18-7010990-40 STD (-0.40 mm)</i></p> <p>18-7010993 0.50</p> <p><i>18-7010993-20 0.50 (-0.20 mm)</i></p> <p><i>18-7010993-40 0.50 (-0.40 mm)</i></p>	<p>A = 29,300 B = 51,000 C = 5,800 D = 0,700 CD= 64,400</p>		<p>ø20,0 x 52,0</p>			



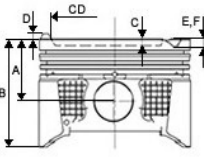







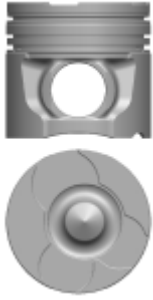

							
Motor /Engine	Ref. No. Kit 1	Ölçüler /Dimensions	Segman /Rings	Pim	Gömlek /Liner	Kit 2	Info
<p>ø82,50</p> <p>4 Cyl. Benzin 1798cc 88/112/118 KW (120/152/160 Ps) CDAA CDAB CDHA CDHB <u>2010 -....</u> Passat 1,8 FSI Golf VI</p>	<p>18-7050460 STD 18-7050463 0.50</p>	<p>A = 29,850 B = 50,350 C = 14,650 D = 5,650 E = -2,000</p> <p>Segman Taşıyıcı (Ring Carrier)</p>	<p>RE56390000 -STD RE56390050 -0.50</p> <p>1,200 () 1,200 () 2,000 ()</p>	<p>ø23,0 x 51,0</p>			
<p>ø82,50</p> <p>4 Cyl. Benzin 1984 cc 110 Kw (150 PS) BLR <u>2004 -....</u> Golf 2.0 FSI 16V Jetta 2.0 FSI 16V Passat 2.0 FSI 16V 2004-</p>	<p>18-7051470 STD 18-7051473 0.50</p>	<p>A = 29,400 B = 47,400 C = 7,360 D = 12,460 E = -1,980</p> <p>Sert Anotlama (Hard Anodising)</p>	<p>RE56370000 -STD RE56370050 -0.50 RE56370100 -1.00</p> <p>1,200 (500) NitB S IF 1,500 (508) P 2,000 (700) Nit S</p>	<p>ø19,0 x 44,0</p>			

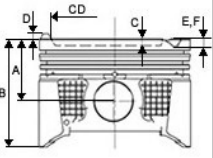





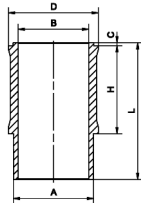
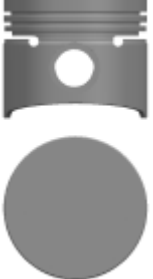
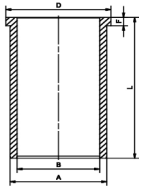

							
Motor /Engine	Ref. No. Kit 1	Ölçüler /Dimensions	Segman /Rings	Pim	Gömlek /Liner	Kit 2	Info
<p>ø82,51</p> <p>4 Cyl. Benzin 1984 cc 132/155/162/165 169/170/175 183/185 KW (180/211/220 224/230/231 238 249/252 CHHA/B CNCD/E CNTA/C CULC/B CVJA CWZA CYMC/NB/PA/PB/RB/RC DAXB/C DYVA DEDA CPLA/PA CXDA DCGA 2013 -</p> <p><i>GOLF VII (5G1-BQ1-BE1-BE2) 2.0 GTI</i></p>	<p>18-7010330 STD 18-7010333 0.50</p> 	<p>A = 29,600 B = 50,100 C = 6,200 E = -3,600 CD= 50,000</p> <p>Segman Taşıyıcı (Ring Carrier)</p>	<p>RE56120000 -STD RE56120050 -0.50</p> <p>1,200 (500) NitB S IF 1,200 (508) P 2,000 (700) 2 (700Nit S</p>	<p>ø23,0 x 51,0</p>			
<p>ø82,51</p> <p>4 Cyl. Diesel 1984 cc 169/195/200 206/210/213/215 221/228</p> <p>KW (265/272/280/286 290/292/300/310 PS) EURO 6 CJXB CJXC CJXD CJXF CJXG CYFB DJHA DJHB DJHC DJJA DLRA DKTA DNUA DNUE CJXA CJXE CJXH -</p> <p><i>EURO 6 CJXB-CJX-CJXD CJXF-CJXG-CYFB DJHA-DJHB-DJHC DJJA-DLRA-DKTA DNUA-DNUE-CJXA CJXE-CJXH</i></p>	<p>18-7010470 STD 18-7010473 0.50</p> 	<p>A = 29,600 B = 50,100 C = 6,200 E = -3,600 CD= 57,500</p> <p>Segman Taşıyıcı (Ring Carrier)</p>	<p>RE56120000 -STD RE56120050 -0.50</p> <p>1,200 (500) NitB S IF 1,200 (508) P 2,000 (700) 2 (700Nit S</p>	<p>ø23,0 x 51,0</p>			

							
Motor /Engine	Ref. No. Kit 1	Ölçüler /Dimensions	Segman /Rings	Pim	Gömlek /Liner	Kit 2	Info
<p>ø83,00</p> <p>6 Cyl. Diesel 2967cc 211/235/245 Ps BUN BUG BKS BSG BKN <u>2007 - 2015</u></p> <p><u>A6 3.0 TDI</u> <u>Q7 3.0 TDI 24V</u> <u>Touareg I 3.0 TDI 24V</u></p>	<p>17-7086880 STD 17-7086883 0.50</p>	<p>A = 46,300 B = 70,800 C = 15,100 CD= 45,000</p> <p>Segman Taşıyıcı (Ring Carrier)</p> <p>Yag Galerisi (Oil Gallery)</p>	<p>RE12280000 -STD RE12280050 -0.50</p> <p>2,000 (500) Cr P 2,000 (501) Cr IFU 3,000 (604) Cr P</p>	<p>ø30,0 x 68,0</p>			
<p>ø93,00</p> <p>4 Cyl. Diesel 2798 cc 116 Kw (158 Ps) BCQ AUH ATA AGK <u>2002 -....</u></p> <p><u>LT28 D</u> <u>LT35 D</u> <u>LT46 D</u></p>	<p>18-7086760 STD 18-7086763 0.50</p>	<p>A = 56,200 B = 86,200 C = 18,500 E = -1,500 CD= 47,100</p> <p>Segman Taşıyıcı (Ring Carrier)</p> <p>Sert Anotlama (Hard Anodising)</p> <p>Yag Püskürt. Oyugu (Oil Cut-Out)</p>	<p>RE56460000 -STD RE56460050 -0.50</p> <p>2,500 (504) Cr P 2,000 (501) P IWU 3,000 (604) Cr P</p>	<p>ø35,0 x 77,0</p>			

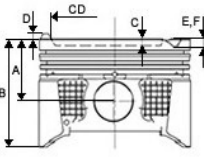





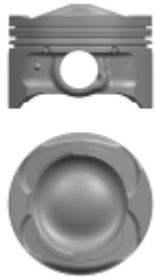
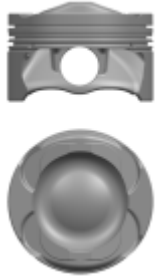

							
Motor /Engine	Ref. No. Kit 1	Ölçüler /Dimensions	Segman /Rings	Pim	Gömlek /Liner	Kit 2	Info
<p>ø93,00</p> <p>4 Cyl. Diesel 2792 cc 116 Kw (158 Ps) AUH BCQ 2003 -.....</p> <p>LT28 D LT35 D LT46 D C.Rail</p>	<p>18-7086770 STD 18-7086773 0.50</p>	<p>A = 56,150 B = 82,200 C = 18,500 E = -1,500 CD= 47,100</p> <p>Segman Taşıyıcı (Ring Carrier)</p> <p>Sert Anotlama (Hard Anodising)</p> <p>Yag Püskürt. Oyugu (Oil Cut-Out)</p>	<p>RE56460000 -STD RE56460050 -0.50</p> <p>2,500 (504) Cr P 2,000 (501) P IWU 3,000 (604) Cr P</p>	<p>ø35,0 x 77,0</p>			



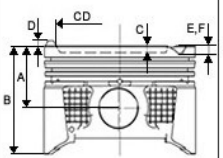







Motor /Engine	Ref. No. Kit 1	Ölçüler /Dimensions	Segman /Rings	Pim	Gömlek /Liner	Kit 2	Info
       							
ø76,00 4 Cyl. Benzin 1397 cc 43 53 Kw (59 72 Ps) C1/2/3/16 J B14 B14 OE 847 700/720 847.2 715/717/742/768 <u>1981 - 1998</u> R18/5/19/21 R12 TSW/TX TOROS R9 BVA AUTOMOTIC R9 GTE BRODWAY/SPRING FUEGO RAPID EXPRESS TRAFIC VOLVO 340/343/345	18-8010190 STD Gömlikli Kodu 19-8010190 STD	A = 37,500 B = 64,000	RE49070000 -STD RE49070050 -0.50 1,750 (500) Cr S IF 2,000 (508) P 4,000 (700) Cr P S	ø20,0 x 64,0	G80551340S_1 A= 80,600 B= 76,000 D= 90,100 F= 0,000 H= 95,000 L= 134,150 		O-Ring Bilgi 04x 77,2x1,25
							
ø76,50 4 Cyl. Diesel 1588 cc 2383 cc 37/40/44/51 /55/57/60,5 Kw (50/54/60/69/75/78/82 Ps) D24 ADK CR JK JP CY JR JX MF ATC 1S CP DW 751 <u>1980 - 1992</u> Volvo 240D/244D/245D/740D Golf Polo Bora Audi 80 1.6D/TD Audi 90 1.6TD Audi 100 2.0D/TD Audi 100 2.4TD SKODA	18-7050760 STD 18-7050763 0.50	A = 41,700 B = 71,700 C = 1,600 Segman Taşıyıcı (Ring Carrier) Sac Plaka (Steel Support)	RE56110000 -STD RE56110050 -0.50 RE56110100 -1.00 1,750 (500) CrB Fe S 2,000 (501) Cr IFU 3,000 (604) Cr	ø24,0 x 64,0	G79501420K_1 A= 79,500 B= 75,810 D= 82,500 F= 4,700 H= 0,000 L= 142,000 		1. çentik 1.40 mm conta + 0,67 + 0,80 2. çentik 1.50 mm conta + 0,81 + 0,90 3. çentik 1.60 mm conta + 0,91 + 1,02
							

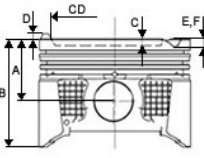







							
Motor /Engine	Ref. No. Kit 1	Ölçüler /Dimensions	Segman /Rings	Pim	Gömlek /Liner	Kit 2	Info
<p>ø79,00</p> <p>4 Cyl. Benzin 1600 cc</p> <p>GÜÇLENDİRİLMİŞ 1.6 EcoBoost</p> <p>.....-.....</p> <p>1.6 EcoBoost</p>	<p>18-2510440 STD</p> <p>18-2510440-30 STD</p> <p>18-2510443 0.50</p> <p>18-2510443-30 0.50</p> <p>18-2510448 1.00</p> <p>18-2510448-30 1.00</p>	<p>A = 28,650</p> <p>B = 54,000</p> <p>C = 5,100</p> <p>D = 6,350</p> <p>E = -3,190</p> <p>F = -2,430</p> <p>CD= 53,500</p> <p>Segman Taşıyıcı (Ring Carrier)</p> <p>Sert Anotlama (Hard Anodising)</p>	<p>RE43490000 -STD</p> <p>RE43490050 -0.50</p> <p>RE43490100 -1.00</p> <p>1,200 (500) NitB S</p> <p>1,200 (501) P</p> <p>2,000 (700) Cr P S</p>	<p>ø21,0 x 46,0</p>			
<p>ø79,00</p> <p>4 Cyl. Benzin 1600 cc</p> <p>1.6 EcoBoost KOL ARASI DÜZ</p> <p>.....-.....</p> <p>1.6 EcoBoost</p>	<p>18-2510460 STD</p> <p>18-2510463 0.50</p> <p>18-2510468 1.00</p>	<p>A = 29,700</p> <p>B = 57,500</p> <p>C = 5,200</p> <p>D = 6,320</p> <p>E = -3,200</p> <p>F = -2,500</p> <p>CD= 53,500</p> <p>Sert Anotlama (Hard Anodising)</p>	<p>RE23080000 -STD</p> <p>RE23080050 -0.50</p> <p>1,200 (500) NitB S</p> <p>1,500 (508) P</p> <p>2,000 (700) Nit S</p>	<p>ø21,0 x 57,0</p>			



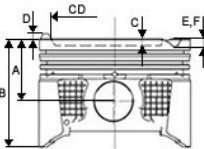





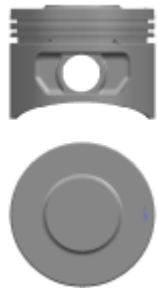

Motor /Engine	Ref. No. Kit 1	Ölçüler /Dimensions	Segman /Rings	Pim	Gömlek /Liner	Kit 2	Info
							
ø81,00 4 Cyl. Benzin 1721 cc 59/60.5/60/90KW (80/82/122 PS) 10:1 F2NA 700/E708 B18E/F/FP/FT 1984 - 1989 Flash R11 GTX/TXE R21 ELECTRONIC R9 GTX/TXE VOLVO 440/460/480	18-8010800 STD 18-8010803 0.50	A = 44,050 B = 70,000 C = 13,900 CD= 60,700 Sac Plaka (Steel Support)	RE49110000 -STD RE49110050 -0.50 1,750 (500) CrB S IF 2,000 (508) P 3,000 (700) Cr P S	ø21,0 x 65,0			
ø85,00 4 Cyl. Diesel 1997/1998 cc 79/80/81/100Kw 90/107/109Ps 110/136 Ps DW10ATED TD10ATED DW10TD Euro 3 G6DB RHS RHW RHX RHY RHZ D420 4T 1998 - 2.0 HDI 206/306/307/406 Boxer Partner Expet C5 Jumpy Xsara Scudo 2.0JTD Cmax Focus II Grand Vitara C30 C70 S40/80 II V50 V70 III TDI	18-7550900 STD 18-7550900-20 STD (-0.20 mm) 18-7550900-40 STD (-0.40 mm) 18-7550903 0.50 18-7550904 0.60	A = 46,750 B = 80,750 C = 18,300 E = -1,000 CD= 38,000 Segman Taşıyıcı (Ring Carrier) Yag Püskürt. Oyugu (Oil Cut-Out)	RE47440000 -STD RE47440060 -0.60 3,500 (505) Cr P 2,000 (501) P IFU 3,000 (604) Cr P	ø28,0 x 70,0			1,25 mm conta +0,55 + 0,60 1,30 mm conta +0,61 +0,65 1,35 mm conta +0,66 +0,70 1,40 mm conta +0,71 +0,75



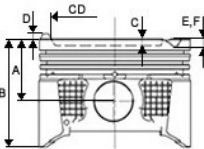



							
Motor /Engine	Ref. No. Kit 1	Ölçüler /Dimensions	Segman /Rings	Pim	Gömlek /Liner	Kit 2	Info
<p>ø87,52</p> <p>4 Cyl. Benzin 1999 cc 176/177/179 KW 239/240/241/243 PS 2.0 Ecoboost TPBA 204PT Euro 5 2.0 4x4 B 4204 T7 T5</p> <p><u>2010 - 2015</u></p> <p>2,0 EcoBoost Discovery Sport L550 Range R.Evoque Cabriolet L538 Freelander 2 L359/LF S60 II 134/124 V60 155/157 V70 III 135 XC60 156</p>	<p>18-2510320 STD 18-2510323 0.50</p>	<p>A = 32,800 B = 53,800 D = 2,190</p> <p>Sert Anotlama (Hard Anodising)</p>	<p>RK25187500010 -STD RK25187500013 -0.50</p> <p>1,200 () Cr S P 1,200 () S P 2,000 () Nit S</p>	<p>ø22,5 x 56,0</p>			
<p>ø88,91</p> <p>4 Benzin 1986 cm 9.2:1 B200 K</p> <p><u>1984</u></p> <p>360 240 Po2o</p>	<p>18-8510180 STD 18-8510183 0.50</p>	<p>A = 39,700 B = 67,700 C = 0,400 CD= 68,000</p> <p>Sac Plaka (Steel Support)</p>	<p>RE57210000 -STD RE57210015 -0.15 RE57210030 -0.30 RE57210050 -0.50</p> <p>1,750 (500) Cr P 1,750 (508) P IF 3,000 (603) P</p>	<p>ø23,0 x 60,0</p>			



							
Motor /Engine	Ref. No. Kit 1	Ölçüler /Dimensions	Segman /Rings	Pim	Gömlek /Liner	Kit 2	Info
<p>ø88,91</p> <p>4 Benzin, 1986 cm 10.0:1 B200 K/E <u>1984</u></p> <p>360 Lomo</p>	<p>18-8510190 STD 18-8510193 0.50</p>	<p>A = 39,700 D = 2,200 CD= 48,700</p> <p>Sac Plaka (Steel Support)</p>	<p>RE57210000 -STD RE57210015 -0.15 RE57210030 -0.30 RE57210050 -0.50</p> <p>1,750 (500) Cr P 1,750 (508) P IF 3,000 (603) P</p>	<p>ø23,0 x 60,0</p>			
<p>ø96,00</p> <p>D2011L041 D2011L04W</p> <p>15052788</p>	<p>18-8550560 STD</p>	<p>A = 51,700 B = 81,600 C = 19,400 CD= 52,000</p>		<p>ø30,0 x 68,0</p>			

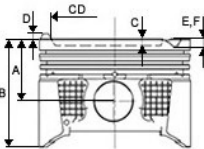
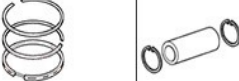

							
Motor /Engine	Ref. No. Kit 1	Ölçüler /Dimensions	Segman /Rings	Pim	Gömlek /Liner	Kit 2	Info
<p>ø107,00</p> <p>6 Cyl. Diesel, 7300 cm³ 158/228 213 Kw (215/310 290 PS) 19,5:1 D7C (215/250/275/290/310) <u>08/1998...12/2001</u></p> <p><i>Turbo LLK 12 Ventile FM 7/250</i></p>	<p>17-8592510 STD</p>	<p>A = 88,450 B = 134,450 C = 20,200 E = -3,000 F = -2,100 CD= 61,000</p> <p>Segman Taşıyıcı (Ring Carrier)</p> <p>Yag Galerisi (Oil Gallery)</p>					
<p>ø108,00</p> <p>4/6 Cyl. Diesel 147/118/265 140 158/162/177 206/235 KW 160/200*360 190/215/220 360/240/280 320 PS TCD 2013 L06 4V Euro 3 Euro4 DXI5 (190/215/220/360) DX7(240/280/320) <u>2006 -.</u></p> <p><i>AGROTRON X TCD 2013 L06 MIDLUM II-SHEPRA D7F240 D7F260 D7F215 D7F290 D7E240 D7F300 D7E280 D7F340 D7E320</i></p>	<p>17-8692100 STD</p>	<p>A = 70,900 B = 107,800 C = 19,600 CD= 64,610</p>		<p>ø45,0 x 86,0</p>			

							
Motor /Engine	Ref. No. Kit 1	Ölçüler /Dimensions	Segman /Rings	Pim	Gömlek /Liner	Kit 2	Info
<p>ø130,18</p> <p>6 Cyl. Diesel 12000 cc 225/173 kw 303/370 Ps 13,3:1 TAD 120 BHC TAMD 120 B TD 120D/C/E <u>1997 - 1984</u></p> <p>F 12-38 F 12-46 F 12-49 F 12-52 F 12-59</p>	<p>17-8550500 STD</p> <p>17-8550500-40 STD (-0.40 mm)</p>	<p>A = 114,200 B = 175,200 C = 27,620 E = -2,500 CD= 83,000</p> <p>Segman Taşıyıcı (Ring Carrier)</p>	<p>RE57110000 -STD</p> <p>2,385 (500) Cr 3,160 (508) Cr P 4,747 (604) Cr P</p>	<p>ø55,0 x 114,0</p>			<p>0,05 + 0,45</p>
